

PRODUCT DESCRIPTION

aSENSE™ m III is a controller with built-in sensors to monitor at the same time *carbon dioxide* and *carbon monoxide*. With these parameters, the programmable unit can control, for example, ventilation rates, and generate alarm signals for personal safety devices.

aSENSE™ m III is designed for both stand-alone operation, as well as being connected to larger building automation systems.



aSENSE™ m III -D
(wall mount)

aSENSE™ m III -K-D
(duct mount)



FEATURES

- State-of-the-art infrared (NDIR) technology to measure carbon dioxide gas
- State-of-the-art hybrid thick film sensor (MMOS) technology to measure carbon monoxide gas.
- Flexible control outputs for connection to DDC, or direct control of dampers and speed regulated fans
- Contributes to lower energy costs when applied in Demand Controlled Ventilation
- Internal data recorder for environmental trend logging
- Serial com port for connection to PC, GSM-module or local network
- Maintenance free more than 5 years

APPLICATIONS

The *aSENSE™ m III* is applicable in most large spaces where *combustion* is the source of the potential toxic danger, such as in *public garages, truck terminals, tunnels and mines*. It offers the possibility to combine CO and CO₂ measurements which not just guarantees public safety, but also saves energy when applied to Demand Controlled Ventilation.

The *aSENSE™ m III* offers the possibility to regulate ventilation systems stand-alone, as well as being just a sensor in a larger system. To cover larger spaces, several sensors could be connected in a simple relay loop and together control an intermittent two-speed exhaust fan, for example. The sensors can also be connected together in a *MODBUS RS485 network* (optional) for serial communication to a global control system or to a simple *web Gateway* for data presentation on the internet.

All engines generate CO and we need protection against this toxic gas. What we do not seem to realize is that a warm, modern engine with catalytic exhaust system typically generates 140 times more CO₂ than CO, in which case the CO₂ constitutes the potential threat. This fact forces us to measure both gases to be able to guarantee personal safety.

AQ Controls Limited

System example *

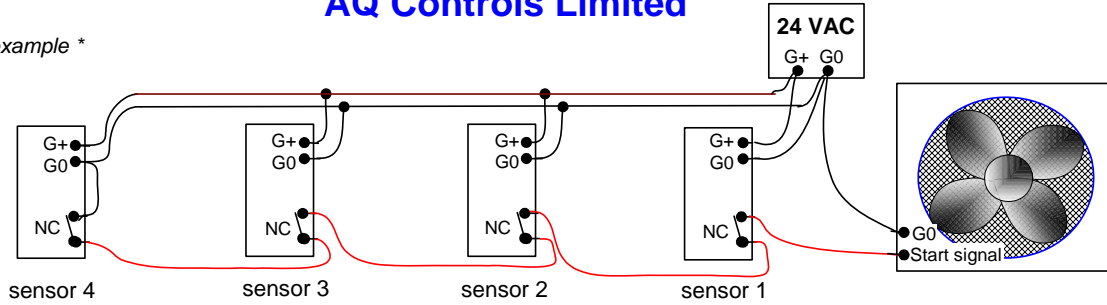

* Read more in SenseAir's Technical Notes *TN-012, TN-020, TN-021, TN-022* www.aqcontrols.com/!

FUNCTIONAL DESCRIPTION

aSENSE™ m III is delivered pre-programmed (see description below). With the free software *UIP4.3* (or later versions), and SenseAir's standard communication cable for PC (art.no. A232 Cable), the user can adjust the product to suit the application. For example, changing the measurement ranges of the linear outputs, modify the set points of the alarm outputs, invert outputs and also reconfigure the functions and the logic that controls the outputs.

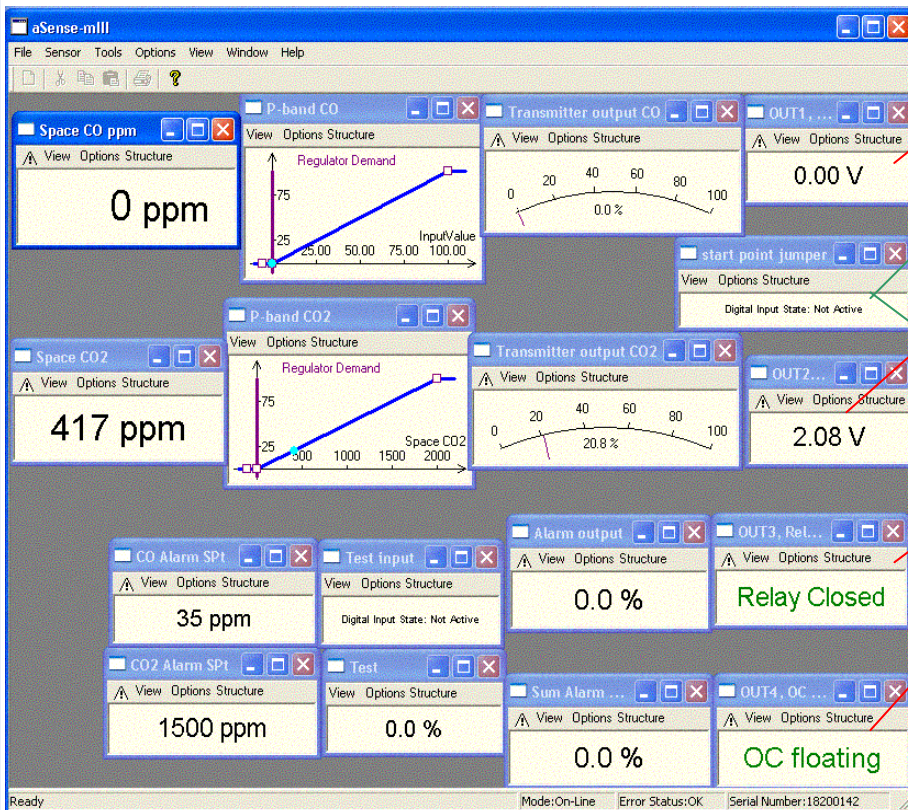

Functions (default)

- **OUT1 = CO-transmitter**, 0/2...10 VDC or 0/4...20 mA for 0...100 ppm CO, for DDC connection. Position of jumper determines current or voltage output mode. Start point jumper for 0-100% or 20-100% signal is common for output 1 and output 2.
- **OUT2 = CO₂ transmitter**, 0/2...10 VDC or 0/4...20 mA for 0...2000 ppm CO₂, for DDC connection. Position of jumper determines current or voltage output mode. Start point jumper for 0-100% or 20-100% signal is common for output 1 and output 2.
- **OUT3 = Gas alarm relay** (Normally Closed) OFF/ON (with hysteresis) for... 35/30 ppm CO OR... 1500/1400 ppm CO₂
- **OUT4 = Sum alarm** (Normally Open) ON/OFF (with hysteresis) for... 35/30 ppm CO OR... 1500/1400 ppm CO₂, OR... *not ready* (15 min delay@cold start) OR... *error* (discovered by the internal diagnostics)

Print screen of *UIP4.3* PC work space of *aSENSE™ m III* where the pre set functions can easily be redefined. The four outputs (far right) are here arranged in rows together with the function blocks that controls the output.

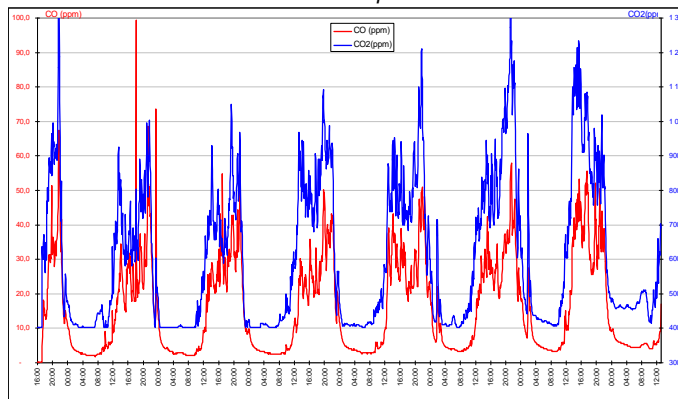

Internal CO and CO₂ recorder samples data continuously every 20 minutes. After 13 days and 8 hours the storage memory is full and the oldest data are eventually overwritten one by one. The data storage is secured every four hours. In case of power failure the sampled data of the latest four hours at most will be lost. The other values can be studied with the software *UIP4.3* and exported to a text file for further treatment in e.g. MS-EXCEL

AQ Controls Limited

Address: Stomnevagen 18, SE-82060 Delsbo, SWEDEN
Phone AU: +61 (0)8 8121 4221 • Phone SE: +46 (0)76 3456 105
E-mail: sales@aqcontrols.com • Web site: www.aqcontrols.com

AQ Controls Limited

aSENSE™ m III CO / CO₂ sensor & ventilation controller Technical Specification

General Performance

Compliance with	EMC directive 89/336/EEC
Operating Temperature Range ¹	0 to +50 °C
Storage Temperature Range	-20 to +70 °C
Operating Humidity Range	0 to 95% RH (non-condensing)
Warm-up Time	≤ 15 minutes (more when un-powered for a long time)
Step response (T ^{1/e})	8 minutes ²
Expected Life Time	> 5 years ²
Self Diagnostics	complete function check of the sensor
Status LED Indicators	<i>yellow</i> = maintenance support, <i>green</i> = relay closed, <i>red</i> = active open collector output
Display	4 Digits, 7 segments LCD with ppm indicator
Pushbuttons	offer a selection of set point adjusts and calibration operation functions
Data logger	internal data logger of CO and CO ₂ readings, 2 x 960 samples, corresponding to just under 2 weeks data sampling of CO- and CO ₂ -values in 20 minutes intervals

Housing Options



WALL MOUNT: with and without display
Protection class: IP54



DUCT MOUNT: with and without display
Protection class: IP65

Electrical/Mechanical/Dimensions

Power Input	24 VAC/DC±20%, 50-60 Hz (half-wave rectifier input)
Power Consumption	≤ 3 Watts average
Wiring Connections	max 1,5 mm ² wires for screw terminal (main terminal) and spring loaded terminal
UART connector	5-pin, 2.54 mm pitch, slide connector (SenseAir standard)
Dimensions of housing	150 x 85 (+ cable throughput 25 mm) x 46 mm (L x W x D). For duct mounted –K sampling probe 245 x 40 mm (L x diameter of hole)

CO₂ Measurement

Operating Principle	Non-dispersive infrared (NDIR) with Automatic Baseline Correction (ABC) ³
Accuracy ⁴	±1% of measurement range ± 5 % of measured value
Pressure Dependence	+ 1.6 % reading per kPa deviation from normal pressure, 100 kPa
Measurement ranges	0 to 3 000 ppm (ranges up to 20 %vol. offered on request)

CO Measurement

Operating Principle	Gas sensitive thick film material (MMOS) internally compensated for <i>temperature and humidity variations</i> , with active carbon filter with Automatic Baseline Correction (ABC) ³
Accuracy ⁴	± 10 ppm
Measurement ranges	0 to 100 ppm (standard)
Extended measurement ranges	100 to 500 ppm (accuracy not specified)

- Not 1:** Lower temperature operation range can be reached by adding a box heater assembly.
- Not 2:** Is limited by the CO probe. More information in SenseAir's Technical note **TN-012** (www.aqcontrols.com).
- Not 3:** The ABC-function is the key to maintenance free operation. It assumes normal operation applications, where ventilation to *some* degree will occur (at least during *some* moment over a week period). This function automatically corrects for any possible *zero* drifts for the CO₂ and the CO sensors.
- Not 4:** In normal ventilated environments. Accuracy is defined at continuous operation (3 weeks minimum after installation)
Please Note! The CO probe also responds to some other chemicals than CO, i.e. silicon. Some non-common operation environments therefore may not be applicable for this product!

AQ Controls Limited

Address: Stomnevagen 18, SE-82060 Delsbo, SWEDEN
Phone AU: +61 (0)8 8121 4221 • Phone SE: +46 (0)76 3456 105
E-mail: sales@aqcontrols.com • Web site: www.aqcontrols.com

Outputs / Terminals

No.	Label	Electrical connection	Function (may be configured with UIP4)
	Main terminal	Screw terminal	
1	G+	24 V AC/DC	
2	G0	Power ground	
3	OUT1	Linear signal (+) 10V/20mA	CO-transmitter. 0...100 ppm
4	OUT2	Linear signal (+) 10V/20mA	CO ₂ -transmitter. 0...2000 ppm
5	M	Signal ground (-)	
6 7	OUT3	OFF/ON-relay (N.C.)	Gas alarm CO = 35/30 ppm or CO ₂ = 1500/1400 ppm
8	OUT4	open-collector (N.O.) or control signal (+)	Operation disturbance alarm or Gas alarm (OUT3-relay closed)
	Extra terminal	Spring-loaded terminal	
9 10	DI 1	Switch with delay timer	Test function (N.O.)

Analogue outputs ⁵

Protection	PTC fuse (auto reset) on signal return <i>M</i> , short-circuit safe
Output limits	MIN & MAX limits may be individually set to all outputs
Linear outputs OUT1 & OUT2	0/2-10 VDC $R_{OUT} < 100 \text{ OHM}$, $R_{load} > 5k \text{ OHM}$ 0/4-20 mA $R_{load} < 500 \text{ OHM}$
Linear output OUT4	0-10 VDC $R_{OUT} < 100 \text{ OHM}$, $R_{load} > 5k \text{ OHM}$
D/A Resolution	10 bits, 10 mV / 0.016 mA
D/A Conversion Accuracy	voltage mode: $\pm 2\%$ of reading $\pm 50 \text{ mV}$ current loop : $\pm 2\%$ of reading $\pm 0.3 \text{ mA}$

ON/OFF

Relay (OUT3)	isolated N.C., 1mA/5V till 1A/50VAC/24VDC.
Open collector OUT4	in ON/OFF mode: max 0.5A/55VDC (half-wave rectifier for AC), closed to ground

UART Serial com port

Protocol	MODBUS, SenseAir protocol ⁶ (see <i>comprot 0800xx rev 1_051.pdf</i>)
PC-interface	RS232 UART cable with sliding contact and driver (model <i>A232 Cable</i>)
PC User Interface Program	UIP version 4.3 (or higher) ⁶ for reconfiguration, maintenance and reading of internal data logger
RS485 network com.	(accessory <i>-485</i>) RS485 PCB mounted onto the UART terminal, network capabilities up to 30 units.

Visual signals

Green LED	Relay output (OUT3) active	<i>Default @ delivery</i> = gas levels below alarm limits
Red LED	Open-collector output (OUT4) active	= operation alarm or gas alarm activated
Yellow LED	Operation error indication	= lit by error status

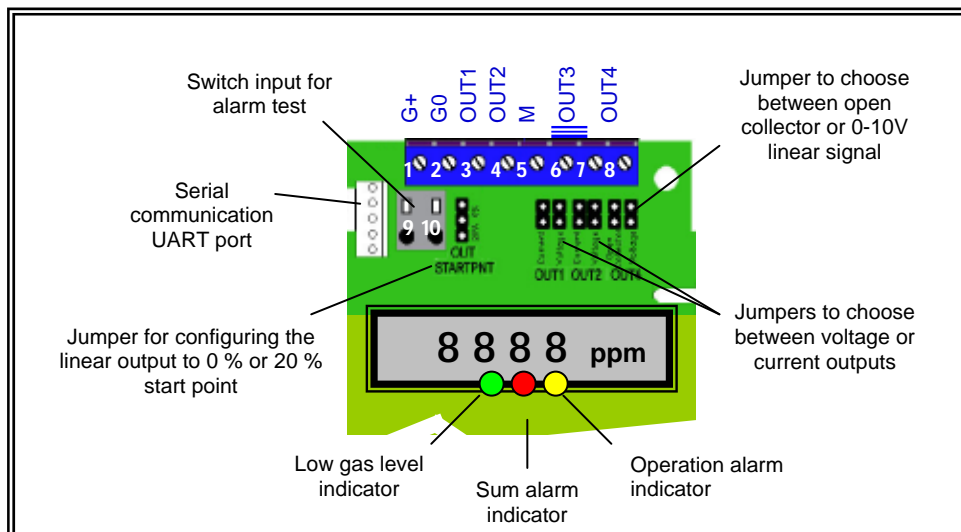

Note 5: The specifications are valid for outputs connected to power ground *G0* or the common signal ground *M*.

Note 6: Free download from SenseAir's home page www.aqcontrols.com.

AQ Controls Limited

Address: Stomnevagen 18, SE-82060 Delsbo, SWEDEN
Phone AU: +61 (0)8 8121 4221 • Phone SE: +46 (0)76 3456 105
E-mail: sales@aqcontrols.com • Web site: www.aqcontrols.com