



User Manual

English

APC Smart-UPS® RT

**Uninterruptible Power Supply
Rack-Mount 3U/Tower**

**SURTD5000/6000RMXLP
120/208/240 Vac**

**SURTD6000RMXLJP
100/200 Vac**

Introduction

The APC Smart-UPS® RT is a high-performance, uninterruptible power supply (UPS) that provides protection for electronic equipment from utility power blackouts, brownouts, sags, and surges. The UPS filters small utility line fluctuations and isolates electronic equipment from large disturbances by internally disconnecting from utility line power. The UPS provides continuous power from the internal battery until utility power returns to safe levels or the battery is fully discharged.

INSTALLATION

Read the Safety Guide before installing the UPS.

Unpacking

Inspect the UPS upon receipt. Notify the carrier and dealer if there is damage.

The packaging is recyclable; save it for reuse or dispose of it properly.

Check the package contents:

- UPS (with battery modules disconnected)
- Front bezel
- Stabilizing feet and screws
- Top cover and screws
- SURTRK2 rail kit
- Serial cable
- Network Management Card (included in the UPS)
- Literature kit containing:
 - Product documentation
 - User Manual CD
 - Warranty Information
 - Software CD
- Network Management Card documentation

Specifications

TEMPERATURE OPERATING STORAGE	0° to 40° C (32° to 104° F) -15° to 45° C (5° to 113° F) charge the UPS battery(s) every six months	This unit is intended for indoor use only. Select a location sturdy enough to handle the weight. Do not operate the UPS where there is excessive dust or the temperature and humidity are outside the specified limits. Ensure that the air vents are not blocked. Environmental factors impact battery life. High temperatures, poor utility power, and frequent, short duration discharges will shorten battery life.
MAXIMUM ELEVATION OPERATING STORAGE	3,000 m (10,000 ft) 15,240 m (50,000 ft)	
HUMIDITY	0 to 95% relative humidity, non-condensing	
WEIGHT UPS UPS WITH PACKAGING	58 kg (128 lbs) 72 kg (159 lbs)	

INSTALL THE MOUNTING RAILS

For detailed rail installation instructions, refer to the rail installation guide included in the rail kit.

INSTALL IN A RACK

For detailed rack installation instructions, refer to the *Installation Guide – Tower to SURTRK2 Rack Conversion* document.

REMOVE THE BATTERIES

The unit is heavy. To lighten the unit, remove the batteries.

1

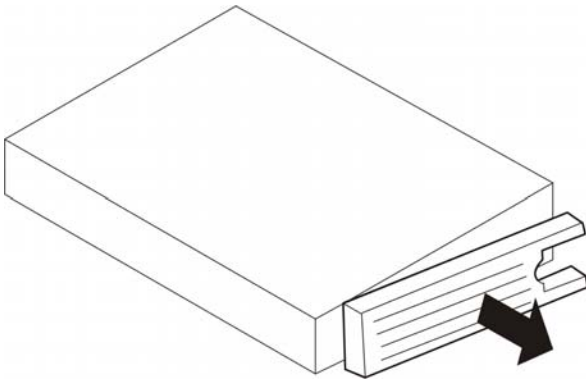

2

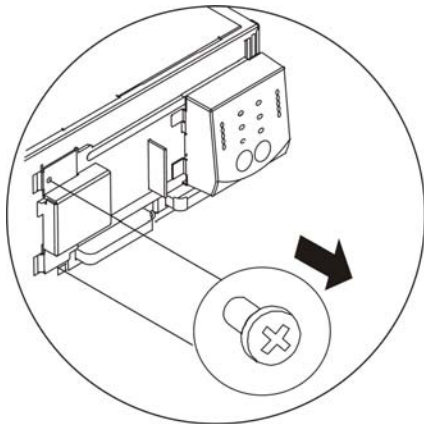

3

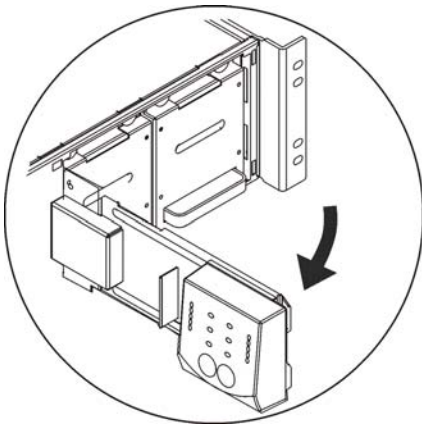

4

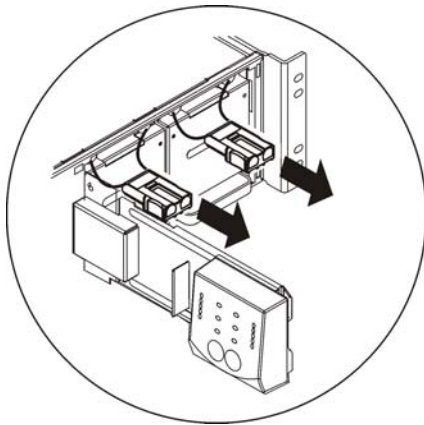

5

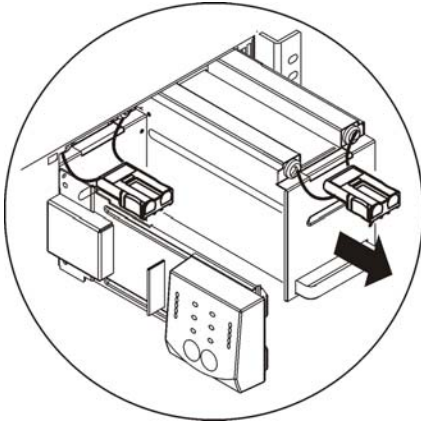

6

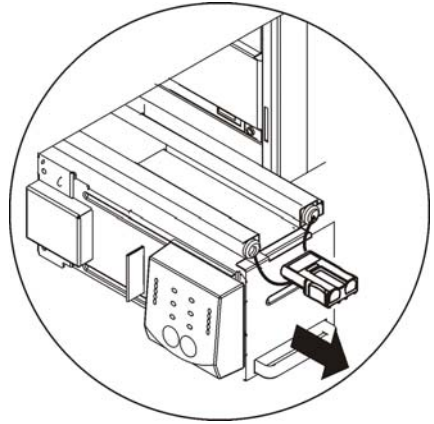

RACK-TO-TOWER CONVERSION

1

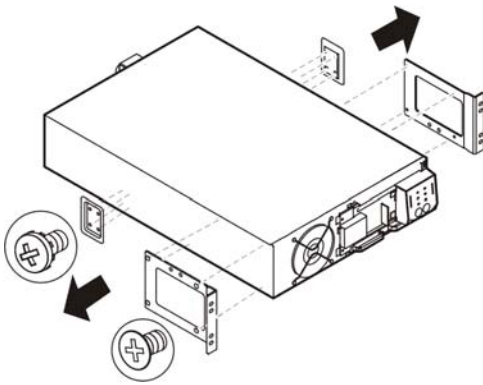

2

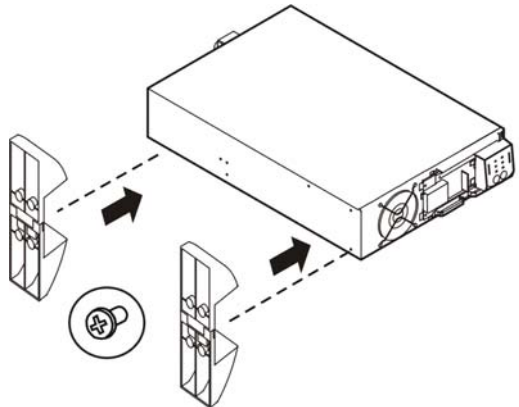

3

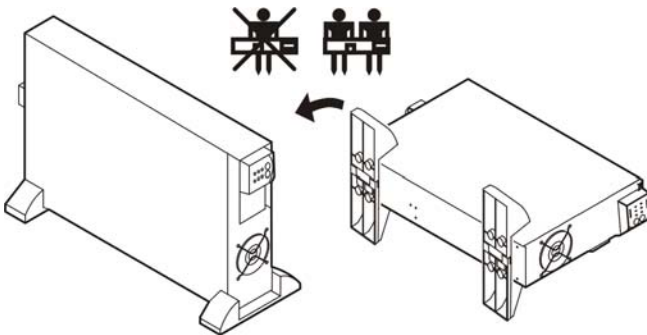

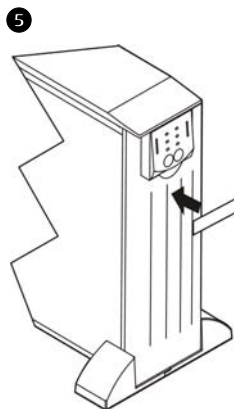
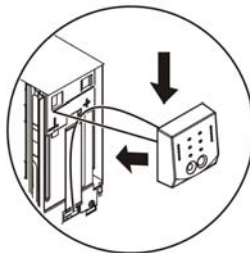
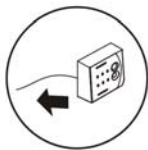
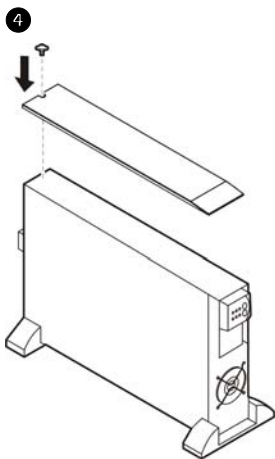

INSTALL THE BATTERIES

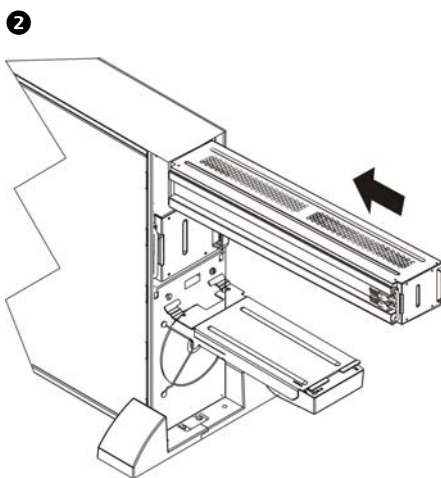
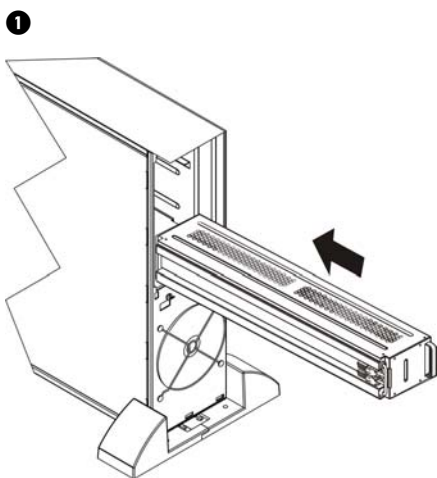

3

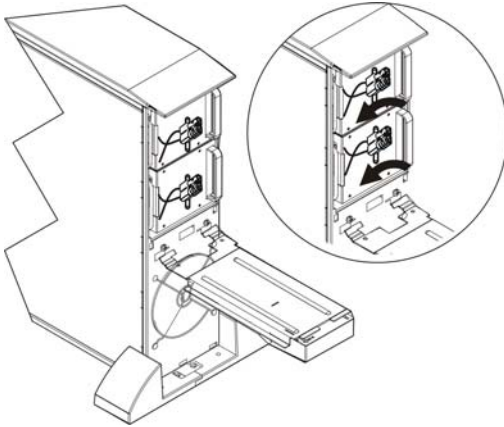

4

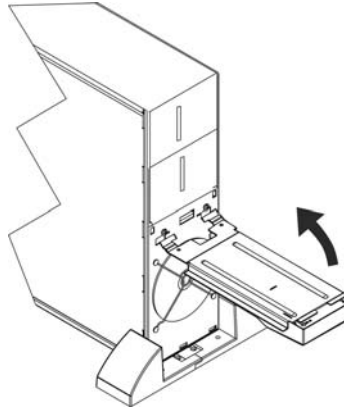

5

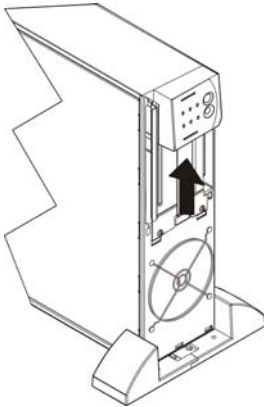

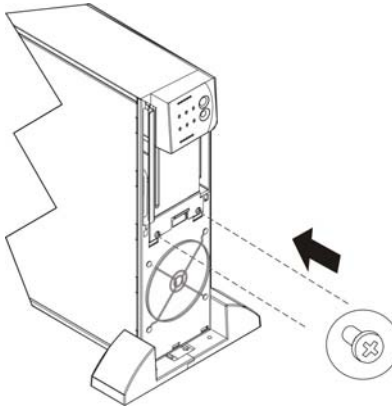

6

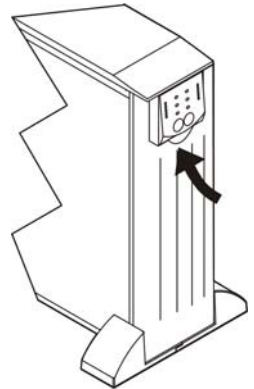

7

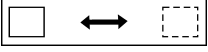

BASIC CONNECTORS

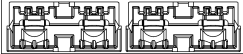
 <p>Serial Port</p>	<p>Connect the UPS to a computer terminal.</p> <p>Use only cables approved by APC.</p> <p>Any other interface cable will be incompatible with the UPS connector.</p>
 <p>On-Line or Bypass Switch</p>	<p>Manually put equipment into bypass mode.</p>
 <p>EPO Terminal</p>	<p>Connect the UPS to the central EPO system.</p>
 <p>TVSS Screw</p>	<p>Connect the ground lead on surge suppression devices, such as telephone and network line protectors.</p> <p>When connecting grounding cable, disconnect the unit from the utility power outlet.</p>
 <p>External Battery Pack Connector</p>	<p>Optional external battery packs provide extended run time during power outages. These units support up to ten external battery packs.</p> <p>See the APC Web site, www.apc.com for the information on the external battery pack, SURT192RMXLBP.</p>

CONNECT EQUIPMENT AND POWER TO THE UPS

1. Connect equipment to the UPS (cables not included). **Avoid using extension cords.**
 - Using a power cord, plug the UPS into a three-pole, four-wire, grounded receptacle only.
 - *SURTD6000RMXLP3U* and *SURTD6000RMXLJP3U* models: To draw full power from the UPS have a qualified electrician cut off the input plug and hardwire the UPS to the appropriate power panel.
2. Turn on all connected equipment. To use the UPS as a master ON/OFF switch, ensure all connected equipment is switched ON. The equipment will not be powered until the UPS is turned on.
3. Press **Test** on the front panel to turn the UPS on.
The UPS battery charges when it is connected to utility power. The battery charges to 90% capacity during the first three hours of normal operation. **Do not** expect full battery run capability during this initial charge period.

OPTIONS

Refer to the APC Web site, www.apc.com for available accessories.

- External Battery Pack SURT192RMXLBP, SURT192XLBP
- Service Bypass Panel

POWER RATINGS OF THE UPS UNDER DIFFERENT LOADS

MAX OUTPUT with Standard Plug, 50-60 Hz		
Model	MAX OUTPUT PER PHASE AT 100 V/ 120 V, SPLIT-PHASE	MAX OUTPUT AT 200 V/208 V (LINE - LINE LOADING)
SURTD5000RMXLP3U	2500 VA, 2000 W, 120 V, 21A	4350 VA, 3500 W, 208 V, 21 A
SURTD6000RMXLP3U	2880 VA, 2100 W, 120 V, 24 A	5000 VA, 3675 W, 208 V, 24 A
SURTD6000RMXLJP3U	2400 VA, 2100 W, 100 V, 24 A	4800 VA, 4200 W, 200 V, 24 A
MAX OUTPUT with Input Hardwired, 50-60 Hz		
Model	MAX OUTPUT PER PHASE AT 100 V/ 120 V, SPLIT-PHASE	MAX OUTPUT AT 200 V/208 V (LINE - LINE LOADING)
SURTD5000RMXLP3U	2500 VA, 2000 W, 120 V, 21A	4350 VA, 3500 W, 208 V, 21 A
SURTD6000RMXLP3U	3000 VA, 2100 W, 120 V, 25 A	5200 VA, 3675 W, 208 V, 25 A
SURTD6000RMXLJP3U	3000 VA, 2100 W, 100 V, 30 A	6000 VA, 4200 W, 200 V, 30 A

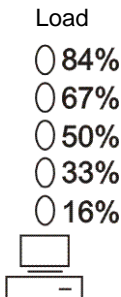

OPERATION



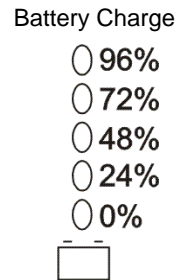
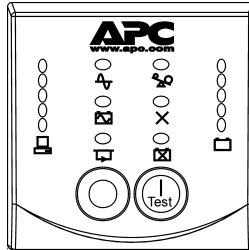





SMART-UPS RT FRONT DISPLAY



Indicator	Description
Online 	The Online LED illuminates when the UPS is drawing utility power and performing double conversion to supply power to connected equipment.
On Battery 	The UPS is supplying battery power to the connected equipment.
Bypass 	The Bypass LED illuminates indicating that the UPS is in bypass mode. Utility power is sent directly to connected equipment during bypass mode. Bypass mode operation is the result of an internal UPS fault, an overload condition or a user initiated command. Battery operation is not available while the UPS is in bypass mode. Refer to <i>Troubleshooting</i> .

Overload 	An overload condition exists. See <i>Troubleshooting</i> .
Fault 	The UPS detects an internal fault. Refer to <i>Troubleshooting</i> in this manual.
Replace Battery 	The battery is disconnected or must be replaced. See <i>Troubleshooting</i> .

Feature	Function												
Power On 	Press this button to turn on the UPS. (See below for additional capabilities.)												
Power Off 	Press this button to turn off the UPS.												
Cold Start 	When there is no utility power and the UPS is off, press and hold the  button to power up the UPS and connected equipment. The UPS will emit two beeps. During the second beep, release the button.												
Self-Test	Automatic: The UPS performs a self-test automatically when turned on, and every two weeks thereafter (by default). During the self-test, the UPS briefly operates the connected equipment on battery. Manual: Press and hold the  button for a few seconds to initiate the self-test.												
Diagnostic Utility Voltage <div style="border: 1px solid black; padding: 5px; margin: 5px 0;"> <table style="width: 100%; border-collapse: collapse;"> <thead> <tr> <th style="text-align: left;">100 V</th> <th style="text-align: left;">120 V</th> </tr> </thead> <tbody> <tr> <td><input type="radio"/> 120 V</td> <td><input type="radio"/> 135 V</td> </tr> <tr> <td><input type="radio"/> 109 V</td> <td><input type="radio"/> 124 V</td> </tr> <tr> <td><input type="radio"/> 98 V</td> <td><input type="radio"/> 113 V</td> </tr> <tr> <td><input type="radio"/> 87 V</td> <td><input type="radio"/> 102 V</td> </tr> <tr> <td><input type="radio"/> 76 V</td> <td><input type="radio"/> 91 V</td> </tr> </tbody> </table> <div style="display: flex; justify-content: space-around; margin-top: 5px;"> <input style="width: 20px; height: 15px;" type="checkbox"/> <input style="width: 20px; height: 15px;" type="checkbox"/> </div> </div>	100 V	120 V	<input type="radio"/> 120 V	<input type="radio"/> 135 V	<input type="radio"/> 109 V	<input type="radio"/> 124 V	<input type="radio"/> 98 V	<input type="radio"/> 113 V	<input type="radio"/> 87 V	<input type="radio"/> 102 V	<input type="radio"/> 76 V	<input type="radio"/> 91 V	<p>The UPS has a diagnostic feature that displays the utility voltage. Plug the UPS into the normal utility power.</p> <p>The UPS starts a self-test as part of this procedure. The self-test does not affect the voltage display.</p> <p>Press and hold the  button to view the utility voltage bar graph display. The five-LED, <i>Battery Charge</i>  display on the right of the front panel shows the utility input voltage.</p> <p>Refer to the figure at left for the voltage reading (values are not listed on the UPS).</p> <p>The display indicates the voltage is between the displayed value on the list and the next higher value.</p> <p>The display shows the high value of the input phase voltages.</p>
100 V	120 V												
<input type="radio"/> 120 V	<input type="radio"/> 135 V												
<input type="radio"/> 109 V	<input type="radio"/> 124 V												
<input type="radio"/> 98 V	<input type="radio"/> 113 V												
<input type="radio"/> 87 V	<input type="radio"/> 102 V												
<input type="radio"/> 76 V	<input type="radio"/> 91 V												

PDU OPTIONS

Default

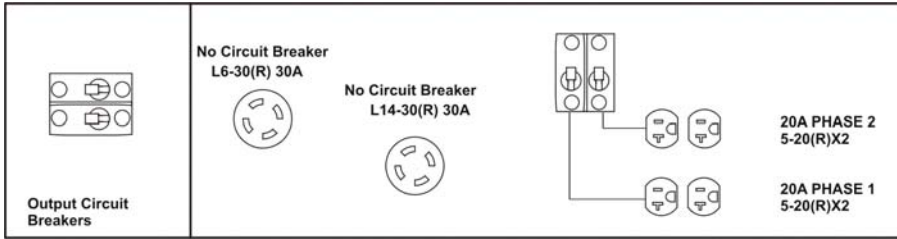

Smart-UPS RT 5/6kVA 100/120/200//208 V PDU Kit—SURT016

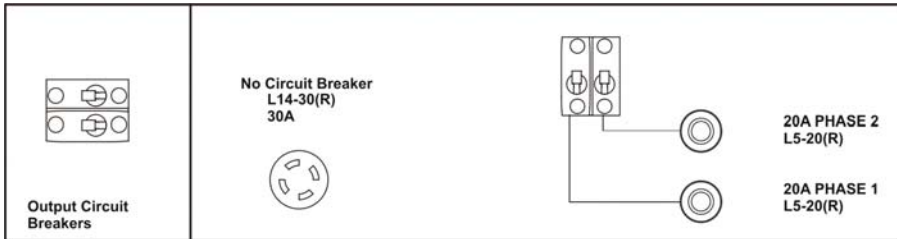

Smart-UPS RT 5/6kVA 200/208 V PDU Kit (20 A)—SURT015

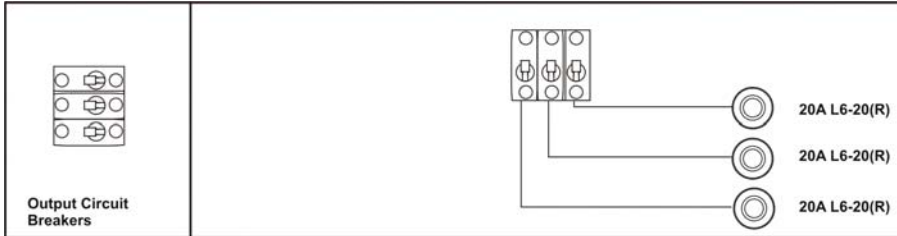

Smart-UPS RT 5/6kVA 100/120 V PDU Kit—SURT014

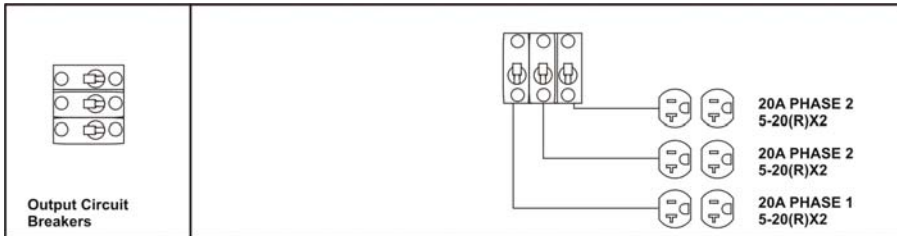

Smart-UPS RT 5/6kVA 200/208 V PDU Kit (30 A)—SURT017

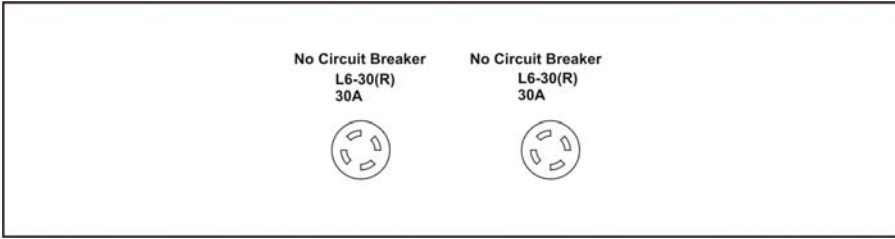

Smart-UPS RT 5/6kVA Input/Output PDU Kit (Hardwire)—SURT018

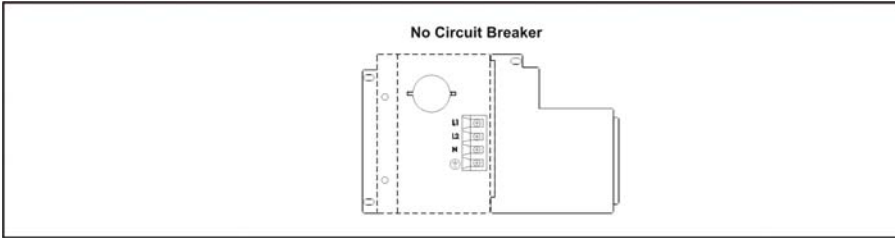

CONFIGURABLE ITEMS

NOTE: SETTINGS ARE MADE THROUGH SMART SLOT ACCESSORY CARDS, OR TERMINAL MODE.			
FUNCTION	FACTORY DEFAULT	USER SELECTABLE CHOICES	DESCRIPTION
Automatic Self-Test	On start-up and every 14 days, thereafter	On start-up and every 7 days thereafter On start-up and every 14 days thereafter On start-up only No self-test	Set the interval at which the UPS will execute a self-test.
Date of Last Battery Replacement	Manufacture date	Date of battery replacement	Reset this date when you replace the battery modules.
Minimum Run time Before Return from Shutdown	0 seconds	0 to 3600 seconds	Specify the amount of battery runtime required to turn the UPS back on after the battery has been completely discharged. This prevents the UPS from turning back on until the batteries have been charged to the specified levels. (Note: 0 disables this function.)
Audible Alarm Setting	ON	ON, OFF	Enable or disable all alarms permanently.

NOTE: SETTINGS ARE MADE THROUGH SMART SLOT ACCESSORY CARDS, OR TERMINAL MODE.			
FUNCTION	FACTORY DEFAULT	USER SELECTABLE CHOICES	DESCRIPTION
Simple Shutdown Delay	90 seconds	0 to 1800 seconds	Set the interval between the time when the UPS receives a simple shutdown command and the actual shutdown.
Simple Low Run Time Warning	150 seconds	0 to 1800 seconds	Change the warning interval default to a higher setting if the operating system requires a longer interval for shutdown. The low battery warning beeps are continuous when 150 seconds of run time remain.
Bypass Tolerance	Wide	Wide, Medium, Narrow, or Custom	Select one of these settings, based on the operating environment. If Wide, Medium, or Narrow is selected, factory defined values are used for the High Bypass Point, Low Bypass Point, and Bypass Acceptable settings. If changes are made to any of these settings, the tolerance value will change to Custom. (See Tolerance Settings at the bottom of this table.)

High Bypass Point	<i>Output Voltage Setting: 200 /100 Vac</i>		Maximum voltage that the UPS will pass to connected equipment during internal bypass operation.
	220/110 Vac	212Vac–280 Vac L-L 106Vac–140 Vac L-N	
	<i>Output Voltage Setting: 208/120 Vac</i>		
	229/132 Vac	220 Vac– 242 Vac L-L 127 Vac–140 Vac L-N	
	<i>Output Voltage Setting: 240 /120 Vac</i>		
	264/132 Vac	254 Vac–280 Vac L-L 127 Vac–140 Vac L-N	

Low Bypass Point	<i>Output Voltage Setting: 200/100 Vac</i>		Minimum voltage that the UPS will pass to connected equipment during internal bypass operation.
	164/82 Vac	170 Vac–184 Vac L-L 85 Vac–92 Vac L-N	
	<i>Output Voltage Setting: 208/120 Vac</i>		
	171/98 Vac	170 Vac–192 Vac L-L 98 Vac–110 Vac L-N	
	<i>Output Voltage Setting: 240 /120 Vac</i>		
	196/98 Vac	170 Vac–220 Vac L-L 85 Vac–110 Vac L-N	
Bypass Acceptable ¹	Not required	Required/Not required	Phase and frequency lock required/not required before the UPS will switch to bypass.
Output Voltage	<i>RMXLP3U models: Auto² 208/240/120 Vac</i>	200/100 Vac, 208/120 Vac, 240/120 Vac, Auto ² 208/240/120 Vac	Allows the user to select the on-line output voltage.
	<i>RMXLJP3U models: 200/100 Vac</i>	200/100 Vac, 208/120 Vac, 240/120 Vac	Allows the user to select the on-line output voltage.
Output Frequency	Automatic 50 ± 3 Hz or 60 ± 3 Hz	50 ± 3 Hz 60 ± 3 Hz 50 ± 1 Hz 60 ± 1 Hz 50 ± 0.1 Hz 60 ± 0.1 Hz Auto 50 ± 3 Hz or 60 ± 3 Hz	Sets the allowable UPS output frequency. Whenever possible, the output frequency tracks the input frequency.

¹ There can be a phase hop in output voltage when 'not required' option is selected in Bypass Acceptable mode.

² The phase voltage in Auto mode is always 120Vac. The Output phase difference between two phases tracks the input phase difference.

Tolerance Settings

	Wide	Medium	Narrow
High Bypass Point	264 Vac L-L/132Vac L-N	260 Vac L-L/130 Vac L-N	254 Vac L-L/127 Vac L-N
Low Bypass Point	197 Vac L-L/98 Vac L-N	208 Vac L-L/104 Vac L-N	220 Vac L-L/110 Vac L-N
Bypass Acceptable	Not Required	Not Required	Not Required
Number of External Battery Packs	0	0 to 100	Defines the number of external connected battery packs for proper run time prediction.

200/100 VAC OUTPUT VOLTAGE SETTING:

	Wide	Medium	Narrow
High Bypass Point	220 Vac L-L/110Vac L-N	216 Vac L-L/108 Vac L-N	212 Vac L-L/106 Vac L-N
Low Bypass Point	164 Vac L-L/82 Vac L-N	174 Vac L-L/87 Vac L-N	184 Vac L-L/92 Vac L-N
Bypass Acceptable	Not Required	Not Required	Not Required

208/120 VAC OUTPUT VOLTAGE SETTING:

	Wide	Medium	Narrow
High Bypass Point	229 Vac L-L/132 Vac L-N	225 Vac L-L/130 Vac L-N	220 Vac L-L/127 Vac L-N
Low Bypass Point	171 Vac L-L/98 Vac L-N	181 Vac L-L/104 Vac L-N	192 Vac L-L/110 Vac L-N
Bypass Acceptable	Not Required	Not Required	Not Required

CONNECTING THE EPO (EMERGENCY POWER OFF) OPTION

The output power can be disabled in an emergency by closing a switch connected to the EPO.

Adhere to national and local electrical codes when wiring the EPO.

The EPO switch is internally powered by the UPS for use with non-powered switch circuit breakers.

The EPO circuit is considered a Class 2 circuit, (UL, CSA standards) and a SELV circuit (IEC standard).

Both Class 2 and SELV circuits must be isolated from all primary circuitry.

Do not connect any circuit to the EPO terminal block unless it can be confirmed that the circuit is Class 2 or SELV.

If circuit standard cannot be confirmed, use a contact closure switch.

Use one of the following cable types to connect the UPS to the EPO switch:

- CL2: Class 2 cable for general use
- CL2P: Plenum cable for use in ducts, plenums, and other spaces used for environmental air.
- CL2R: Riser cable for use in a vertical run in a floor to floor shaft.
- CLEX: Limited use cable for use in dwellings and for use in raceways.
- For installation in Canada: Use only CSA certified, type ELC (extra-low voltage control cable).

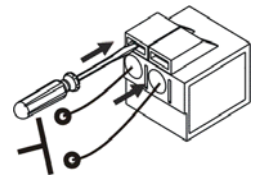

Configure UPS Parameters using terminal mode

Terminal Mode is a menu driven interface that enables configuration of the UPS by users not using the installed Network Management Card interfaces.

CONFIGURE UPS CONNECTION USING TERMINAL MODE

1. Connect the serial cable to the serial port on the back of the UPS.
2. Open a terminal program, such as HyperTerminal[®]. From the desktop, go to **Start, Programs, Accessories, Communication, HyperTerminal**.
3. Follow the prompts to choose a name and select an icon. Disregard the message, "...must install a modem," if it is displayed. Click OK.
4. Select **File, Properties**.
5. Select the **COM** port that is connected to your UPS.
6. Click **Configure**.
7. Enter the settings:
 - *bits per second - 9600*
 - *data - bits 8*
 - *parity - none*
 - *stop bit - 1*
 - *flow control - none*
8. Click **OK**.
9. Press **Enter** to initiate the connection to the UPS.

CONFIGURE NUMBER OF BATTERY PACKS USING TERMINAL MODE

1. Connect to the unit (see *Configure UPS Connection using Terminal Mode*).
2. Press **1** to modify the UPS settings.
3. Press **D - # of External Battery Packs**.
4. Enter the number of battery packs
5. Press **Enter** and **Y** to accept the changes.
6. Press **ESC** to exit the program.

CONFIGURE THE UPS CONNECTING USING NMC TERMINAL MODE

1. Connect the serial cable to the serial port on the back of the UPS. (If using USB communication to the UPS, disconnect the USB cable first.)
2. Open a terminal program, such as HyperTerminal[®]. From the desktop, go to **Start, Programs, Accessories, Communication, HyperTerminal**.
3. Follow the prompts to choose a name and select an icon. Disregard the message, "...must install a modem," if it is displayed. Click OK.
4. Select **File, Properties**.
5. Select the **COM** port that is connected to your UPS.
6. Click **Configure**.





7. Enter the settings:
 - *bits per second - 9600*
 - *data - bits 8*
 - *parity - none*
 - *stop bit - 1*
 - *flow control – none*
8. Click **OK**.
9. Press **Enter** to initiate the connection to the UPS.

CONFIGURE THE NUMBER OF BATTERY PACKS USING NMC TERMINAL MODE

1. Once the blank terminal window is open, press **Enter** multiple times, until the prompt.
2. Press 1 and **Enter** to select Device Manager. Select the model by entering the corresponding number, then press ENTER.
3. Press 3 and **Enter** to select Configuration.
4. Press 1 and **Enter** to select Battery.
5. Press 2 and **Enter** to change the Battery Settings.
6. Type in the number of external battery packs (four battery modules per pack), and press ENTER. (Number of packs: 1 = 1 SURT192RMXLBP, 2 = 2 SURT192RMXLBP etc.)
7. Press 3 and ENTER to accept the changes.
8. Press ESC multiple times (5) to return to the main menu.
9. Press 4 and ENTER to log out.

TROUBLESHOOTING

Use the table below to solve minor installation and operation problems. Refer to the APC Web site, www.apc.com for assistance with complex UPS problems.

PROBLEM AND POSSIBLE CAUSE	SOLUTION
<i>UPS WILL NOT TURN ON</i>	
Battery not connected properly.  button not pushed. UPS not connected to utility power supply. Very low or no utility voltage.	Check that the battery connectors are fully engaged. Press the  button once to power the UPS and the connected equipment. Check that the power cable from the UPS to the utility power supply is securely connected at both ends. Check the utility voltage.
<i>UPS WILL NOT TURN OFF</i>	
 button not pushed. Internal UPS fault.	Press the  button once to turn the UPS off. Do not attempt to use the UPS. Unplug the UPS and have it serviced immediately.
<i>UPS BEEPS OCCASIONALLY</i>	
Normal UPS operation when running on battery.	None. The UPS is protecting the connected equipment.
<i>UPS DOES NOT PROVIDE EXPECTED BACKUP TIME</i>	
The UPS battery(s) are weak due to a recent outage or battery(s) are near the end of their service life.	Charge the battery(s). Battery modules require recharging after extended outages. They wear faster when put into service often or when operated at elevated temperatures. If the battery(s) are near the end of their service life, consider replacing the battery(s) even if the <i>Replace Battery</i> LED is not illuminated.
<i>FRONT PANEL LEDs FLASH SEQUENTIALLY</i>	
The UPS has been shut down remotely through software or an optional accessory card.	None. The UPS will restart automatically when utility power returns.
<i>ALL LEDs ARE OFF AND THE UPS IS PLUGGED INTO A WALL OUTLET</i>	
The UPS is shut down and the battery is discharged from an extended outage.	None. The UPS will return to normal operation when the power is restored and the battery has a sufficient charge.
<i>BYPASS AND OVERLOAD LEDs ILLUMINATE, UPS EMITS A SUSTAINED ALARM TONE</i>	
The UPS is overloaded	The connected equipment exceeds the specified "maximum load" as defined in <i>Specifications</i> on the APC Web site, www.apc.com . The alarm remains on until the overload is removed. Disconnect nonessential equipment from the UPS to eliminate the overload condition.

PROBLEM AND POSSIBLE CAUSE	SOLUTION
<i>BYPASS LED ILLUMINATES</i>	
The bypass switch has been turned on manually or through an accessory.	If bypass is the chosen mode of operation, ignore the illuminated LED. If bypass is not the chosen mode of operation move the bypass switch on the back of the UPS, to the <i>normal</i> position.
<i>FAULT AND OVERLOAD LEDs ILLUMINATE, UPS EMITS A SUSTAINED ALARM TONE</i>	
The UPS has ceased sending power to connected equipment.	The connected equipment exceeds the specified “maximum load” as defined in <i>Specifications</i> on the APC Web site, www.apc.com . Disconnect nonessential equipment from the UPS to eliminate the overload condition. Press the OFF button, then the ON button to restore power to connected equipment.
<i>FAULT LED ILLUMINATES</i>	
Internal UPS fault.	Do not attempt to use the UPS. Turn the UPS off and have it serviced immediately.
<i>REPLACE BATTERY LED ILLUMINATES</i>	
Replace Battery LED flashes and short beep is emitted every two seconds to indicate the battery is disconnected. Weak battery. Failure of a battery self-test.	Check that the battery connectors are fully engaged. Allow the battery to recharge for 24 hours. Then, perform a self-test. If the problem persists after recharging, replace the battery. The UPS emits short beeps for one minute and the <i>Replace Battery LED</i> illuminates. The UPS repeats the alarm every five hours. Perform the self-test procedure after the battery has charged for 24 hours to confirm the <i>Replace Battery</i> condition. The alarm stops and the LED clears if the battery passes the self-test.
<i>UPS OPERATES ON BATTERY ALTHOUGH NORMAL LINE VOLTAGE EXISTS</i>	
Very high, low, or distorted line voltage. Inexpensive fuel powered generators can distort the voltage.	Move the UPS to a different outlet on a different circuit. Test the input voltage with the utility voltage display.
<i>DIAGNOSTIC UTILITY VOLTAGE</i>	
All five LEDs are illuminated	The line voltage is extremely high and should be checked by an electrician.
There is no LED illumination	If the UPS is plugged into a properly functioning utility power outlet, the line voltage is extremely low.
<i>ONLINE LED</i>	
There is no LED illumination	The UPS is running on battery, or it is not turned on.
The LED is blinking	The UPS is running an internal self-test.

MAINTENANCE, TRANSPORT, AND SERVICE

Replacing the Battery Module

This UPS has an easy to replace, hot-swappable battery module. Replacement is a safe procedure, isolated from electrical hazards. You may leave the UPS and connected equipment on during the procedure. See your dealer or contact APC at the Web site, www.apc.com for information on replacement battery modules.

The battery replacement procedure must include replacing all battery modules in the UPS and connected external battery pack(s).

See *Removing the Batteries* and *Installing the Batteries* in this manual for additional information.



Once the battery(s) are disconnected, the connected equipment is not protected from power outages.

Be careful during battery replacement, the battery modules are heavy.



Be sure to deliver spent batteries to a recycling facility or ship to the manufacturer in the replacement battery packing material.

Disconnecting the Battery for Transport

Always DISCONNECT THE BATTERY(s) before shipping in compliance with U.S. Department of Transportation (DOT) and IATA regulations.

The battery(s) may remain in the UPS.

1. Shut down and disconnect any equipment attached to the UPS.
2. Shut down and disconnect the UPS from the power supply.
3. Unplug the battery connectors. Refer to the *Replacing Battery Modules* section in this manual.

For shipping instructions contact APC at the Web site, www.apc.com.

Service

If the UPS requires service do not return it to the dealer. Follow these steps:

1. Review the problems discussed in the *Troubleshooting* section of this manual to eliminate common problems.
2. If the problem persists, contact APC Customer Support through the APC Web site, www.apc.com.
 - Note the model number of the UPS, the serial number located on the back of the unit, and the date purchased. If you call APC Customer Support, a technician will ask you to describe the problem and attempt to solve it over the phone. If this is not possible, the technician will issue a Returned Material Authorization Number (RMA#).
 - If the UPS is under warranty, repairs are free.
 - Procedures for servicing or returning products may vary internationally. Refer to the APC Web site for country specific instructions.
3. Pack the UPS in its original packaging.
 - If the original packing is not available, refer to the APC Web site, www.apc.com for information about obtaining a new set.
 - Pack the UPS properly to avoid damage in transit. Never use Styrofoam beads for packaging. Damage sustained in transit is not covered under warranty.

Always DISCONNECT THE BATTERY(S) before shipping in compliance with U.S. Department of Transportation (DOT) and IATA regulations.

The battery(s) may remain in the UPS.

4. Mark the RMA# on the outside of the package.
5. Return the UPS by insured, prepaid carrier to the address given to you by Customer Support.

REGULATORY AND WARRANTY INFORMATION

Regulatory Agency Approvals and Radio Frequency Warnings

200, 208, 240 V MODELS

This equipment has been tested and found to comply with the limits for a Class A digital device, pursuant to part 15 of the FCC Rules. These limits are designed to provide reasonable protection against harmful interference when the equipment is operated in a commercial environment. This equipment generates, uses, and can radiate radio frequency energy and, if not installed and used in accordance with the instruction manual, may cause harmful interference to radio communications. Operation of this equipment in a residential area is likely to cause harmful interference. The user is responsible for correcting the interference.

Shielded signal cables must be used with this product to ensure compliance with the Class A FCC limits.



この装置は、情報処理装置等電波障害自主規制協議会 (VCCI)の基準に基づくクラスA情報技術装置です。この装置を家庭環境で使用すると電波妨害を引き起こすことがあります。この場合には使用者が適切な対策を講ずるよう要求されることがあります。 VCCI-A

Two Year Factory Warranty¹

The limited warranty provided by American Power Conversion (APC®) in this Statement of Limited Factory Warranty applies only to Products you purchase for your commercial or industrial use in the ordinary course of your business.

Terms of Warranty

APC warrants its products to be free from defects in materials and workmanship for a period of two years from the date of purchase. The APC obligation under this warranty is limited to repairing or replacing, at its sole discretion, any such defective products. This warranty does not apply to equipment that has been damaged by accident, negligence or misapplication or has been altered or modified in any way. Repair or replacement of a defective product or part thereof does not extend the original warranty period. Any parts furnished under this warranty may be new or factory remanufactured.

Non-transferable Warranty

This warranty applies only to the original purchaser who must have properly registered the product. Product may be registered at www.apc.warranty.com.

Exclusions

APC shall not be liable under the warranty if its testing and examination disclose that the alleged defect in the product does not exist or was caused by end user or any third person misuse, negligence, improper installation or testing. Further APC shall not be liable under the warranty for unauthorized attempts to repair or modify wrong or inadequate electrical voltage or connection, inappropriate on-site operation conditions, corrosive atmosphere, repair, installation, start-up by non-APC designated personnel, a change in location or operating use, exposure to the elements, Acts of God, fire, theft, or installation contrary to APC recommendations or specifications or in any event if the APC serial number has been altered, defaced, or removed, or any other cause beyond the range of the intended use.

THERE ARE NO WARRANTIES, EXPRESS OR IMPLIED, BY OPERATION OF LAW OR OTHERWISE, OF PRODUCTS SOLD, SERVICED OR FURNISHED UNDER THIS AGREEMENT OR IN CONNECTION HEREWITH. APC DISCLAIMS ALL IMPLIED WARRANTIES OF MERCHANTABILITY, SATISFACTION AND FITNESS FOR A PARTICULAR PURPOSE. APC EXPRESS WARRANTIES WILL NOT BE ENLARGED, DIMINISHED, OR AFFECTED BY AND NO OBLIGATION OR LIABILITY WILL ARISE OUT OF, APC RENDERING OF TECHNICAL OR OTHER ADVICE OR SERVICE IN CONNECTION WITH THE PRODUCTS. THE FOREGOING WARRANTIES AND REMEDIES ARE EXCLUSIVE AND IN LIEU OF ALL OTHER WARRANTIES AND REMEDIES. THE WARRANTIES SET FORTH ABOVE CONSTITUTE APC SOLE LIABILITY AND PURCHASER'S EXCLUSIVE REMEDY FOR ANY BREACH OF SUCH WARRANTIES. APC WARRANTIES RUN ONLY TO PURCHASER AND ARE NOT EXTENDED TO ANY THIRD PARTIES.

IN NO EVENT SHALL APC, ITS OFFICERS, DIRECTORS, AFFILIATES OR EMPLOYEES BE LIABLE FOR ANY FORM OF INDIRECT, SPECIAL, CONSEQUENTIAL OR PUNITIVE DAMAGES, ARISING OUT OF THE USE, SERVICE OR INSTALLATION, OF THE PRODUCTS, WHETHER SUCH DAMAGES ARISE IN CONTRACT OR TORT, IRRESPECTIVE OF FAULT, NEGLIGENCE OR STRICT LIABILITY OR WHETHER APC HAS BEEN ADVISED IN ADVANCE OF THE POSSIBILITY OF SUCH DAMAGES. SPECIFICALLY, APC IS NOT LIABLE FOR ANY COSTS, SUCH AS LOST PROFITS OR REVENUE, LOSS OF EQUIPMENT, LOSS OF USE OF EQUIPMENT, LOSS OF SOFTWARE, LOSS OF DATA, COSTS OF SUBSTITUANTS, CLAIMS BY THIRD PARTIES, OR OTHERWISE.

NO SALESMAN, EMPLOYEE OR AGENT OF APC IS AUTHORIZED TO ADD TO OR VARY THE TERMS OF THIS WARRANTY. WARRANTY TERMS MAY BE MODIFIED, IF AT ALL, ONLY IN WRITING SIGNED BY AN APC OFFICER AND LEGAL DEPARTMENT.

Warranty Claims

Customers with warranty claims issues may access the APC worldwide customer support network by referring to the APC Web site, www.apc.com. Select your country from the country selection pull-down menu. Open the Support tab at the top of the web page to obtain contact information for customer support in your region.

¹ To determine which factory warranty applies to the APC product you purchased, consult the factory warranties located on the APC Web site, www.apc.com/products.

APC Worldwide Customer Support

Customer support for this or any other APC product is available at no charge in any of the following ways:

- Refer to the APC Web site to access documents in the APC Knowledge Base and to submit customer support requests.
 - **www.apc.com** (Corporate Headquarters)
Connect to localized APC Web sites for specific countries, each of which provides customer support information.
 - **www.apc.com/support/**
Global support searching APC Knowledge Base and using e-support.
- Contact an APC Customer Support center by telephone or e-mail.
Local, country-specific centers:
go to **www.apc.com/support/contact** for information.

Contact the APC representative or other distributor from whom you purchased your APC product for information on how to obtain local customer support.

Entire contents copyright 2008 American Power Conversion Corporation. All rights reserved. Reproduction in whole or in part without permission is prohibited.

APC, the APC logo, Smart-UPS, and PowerChute are trademarks of American Power Conversion Corporation. All other trademarks, product names, and corporate names are the property of their respective owners and are used for informational purposes only.