



TAC
1354 Clifford Avenue
P. O. Box 2940
Loves Park, IL 61132-2940
www.tac.com

VB-8213 Series

**2-1/2" to 6" 125 psi Flanged
Stem Up Open
Two-Way Valves
General Instructions**

Application

VB-8213 series single seat, stem down to close, two-way valves control water from 20 to 281°F (-7 to 138°C) or steam to 281°F (138°C) maximum in heating or air conditioning systems. They are used for two-position or proportional electric/electronic or pneumatic control of hot water, chilled water, or low pressure steam. Valve assemblies require an actuator and valve linkage that may be purchased separately or as part of a complete factory valve assembly.



Danger: Do not use for combustible gas applications. The VB-8213 series valve packings are not rated for combustible gas applications, and if used in these applications, gas leaks and explosions may result.

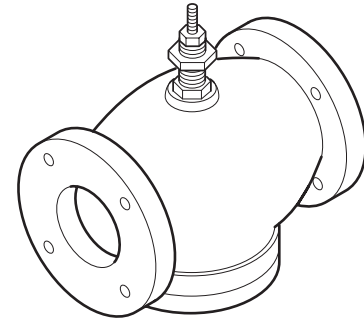

Typical of VB-8213-0-5-P
2-1/2" to 6"

Features

- Valve sizes 2-1/2" to 6"
- 125 psig pressure rating per ANSI Standards (B16.1-1993) for flanged cast iron bodies
- Excellent close-off capability up to 125 psi
- Meets ANSI IV seat leakage specifications (0.01% of Cv)
- Self-adjusting spring-loaded TFE/EPDM packing
- Expanded operating temperatures 20 to 281°F

Applicable Literature

F-Number	Description	Audience	Purpose	
F-27199	Vx-8xxx Series Selection Guide	<ul style="list-style-type: none"> – Sales Personnel – Application Engineers – Installers – Service Personnel – Start-up Technicians 	Provides features, specifications, mounting dimensions, and other criteria useful to the selection of Vx-8xxx series valves.	
F-27383	TAC Pneumatic Products Catalog		Provides a comprehensive listing of TAC component products, describing their features and specifications, and provides other reference material useful to their selection.	
F-26642	MA40-704x, MA4x-707x, MA4x-715x TAC DuraDrive™ Series Spring Return Two-Position Actuators General Instructions		<ul style="list-style-type: none"> – Sales Personnel – Application Engineers – Installers – Service Personnel – Start-up Technicians 	<p>Describes the actuator's features, specifications, and possible applications.</p>
F-13895	MK-6xxx Series Proportional Pneumatic Actuators General Instructions			
F-26644	MF4x-7xx3, MF4x-7xx3-50x TAC DuraDrive Series Spring Return Floating Actuator General Instructions			
F-26744	MF41-6343 TAC DuraDrive Series Non-Spring Return Direct Coupled Actuator General Instructions			
F-24732	MF-631x3 Floating Valve Actuator General Instructions			
F-26745	MS40-634x TAC DuraDrive Series Non-Spring Return Direct Coupled Actuator General Instructions			
F-27120	Mxx1-720x TAC DuraDrive Series Actuator General Instructions			
F-27253	AV-497 Valve Linkage for MK-6811 and MK-6911 General Instructions			
F-27082	AV-607 and AV-609 TAC DuraDrive Linkages for 2-1/2" to 6" Valves General Instructions			
F-24842	AV-672 Electric/Electronic Valve Linkage Kit General Instructions			
F-26080	EN-205 Water System Guidelines	<ul style="list-style-type: none"> – Application Engineers – Installers – Service Personnel – Start-up Technicians 	Provides treatment guidelines for water and steam systems.	

SPECIFICATIONS

Table-1 Specifications/Models

Specifications			Valve Body Series VB-8213-0-5-P
Service			Chilled or Hot Water (up to 50% Glycol) and Steam
Flow Characteristics (Figure-1)			Equal Percentage
Sizes			2-1/2" to 6"
Type of End Fitting			125 psi Flanged
Valve Materials	Body		Cast Iron
	Seat		Forged Brass
	Stem		Stainless Steel
	Plug		Forged Brass
	Packing		Spring-loaded TFE/EPDM
	Seat Ring		EPDM
ANSI Pressure Class (Figure-2)			125 psi Flanged (up to 200 psig below 150°F)
Maximum Inlet Pressure, Steam			35 psig (241 kPa)
Allowable Control Media Temperature			20 to 281°F (-7 to 138°C)
Close-off Pressure ^a			125 psi (856 kPa)
Allowable Differential Pressure for Steam ^b			20 psi (138 kPa)
Valve Size	C _v Rating ^c	k _{vs} Rating ^c	Complete Valve Body Part Number
2-1/2"	56	48	VB-8213-0-5-12
3"	85	74	VB-8213-0-5-13
4"	145	125	VB-8213-0-5-14
5"	240	208	VB-8213-0-5-15
6"	370	320	VB-8213-0-5-16

^a Exceeding close-off pressure voids product warranty. Do not exceed maximum operating pressure differential. See Vx-8xxx Selection Guide, F-27199 for maximum operating pressure differentials.

^b Maximum recommended differential pressure in closed position. Do not exceed recommended differential pressure or integrity of parts may be affected.

^c $C_v = \frac{gpm}{\sqrt{\Delta P}}$ (where ΔP is measured in psi) $k_{vs} = C_v / 1.156$ $k_{vs} = \frac{m^3/h}{\sqrt{\Delta P}}$ (where ΔP is measured in bar; 1 bar = 100 kPa)

Maximum Operating Pressure Differential

The maximum operating pressure differential is dependent on the size of the valve and the actuator. See the *Vx-8xxx Selection Guide*, F-27199, for maximum operating pressure differential ratings.

Normal Position of Valve Assembly

For a valve assembly (valve, linkage, and actuator) to have a normal position, the actuator must be of the spring return type. See Table-2 for compatible spring return and non-spring return actuators and their normal (stem up) positions.

Table-2 Typical Compatible Actuators and Linkages

Actuator Series	Control Signal Type	Spring Return	Required Valve Linkage		Normal Position
			2-1/2" to 5" Valves	6" Valves	
MA61-7200	Two Position 120 Vac	Yes	None ^a	—	Open
MA61-7201	Two Position 230 Vac	Yes	None ^a	—	Open
MA61-7203	Two Position 24 Vac	Yes	None ^a	—	Open
MA41-7150	Two Position 120 Vac	Yes	AV-607	AV-609	Open ^b
MA41-7151	Two Position 230 Vac	Yes	AV-607	AV-609	Open ^b
MA41-7153	Two Position 24 Vac	Yes	AV-607	AV-609	Open ^b
MA40-7170	Two Position 120 Vac	Yes	AV-607	AV-609	Open ^b
MA40-7171	Two Position 230 Vac	Yes	AV-607	AV-609	Open ^b
MA40-7173	Two Position 24 Vac	Yes	AV-607	AV-609	Open ^b
MF-63103	Floating 24 Vac	No	AV-672	—	None
MF-63123 ^c	Floating 24 Vac ^c	No	AV-672	—	None
MF-63123-211 ^d	Proportional Vdc	No	AV-672	—	None
MF-63123-411 ^e	Proportional mA _{dc}	No	AV-672	—	None
MF41-6343	Floating 24 Vac	No	—	AV-609	None
MF41-7153		Yes	AV-607	AV-609	Open ^b
MF40-7173			None ^a	—	Open
MF61-7203			AV-607	AV-609	Open ^b
MK-6811 ^f	Pneumatic 5 to 10 psig ^f	Yes	AV-497	—	Open
MK-6911 with AK-42309-500 ^g	Pneumatic 5 to 10 psig ^g	Yes	—	AV-497	Open
MS41-7153	Proportional 2 to 10 Vdc ^h	Yes	AV-607	AV-609	Open
MS40-7170	Proportional 2 to 10 Vdc ^h	Yes	AV-607	AV-609	Open ^b
MS40-7171					
MS40-7173					
MS41-6340	Proportional 2 to 10 Vdc ^h	No	—	AV-609	None
MS41-6341					
MS41-6343					
MS61-7203					

^a Linkage integral to actuator.

^b As shipped from factory. May be field configured for normally closed (spring return stem down).

^c MFC-8000 and MFC-420 plug-in control modules may be field installed for proportional control.

^d MFC-8000 control module factory installed, set for 6 to 9 Vdc, 1" (25 mm) stroke.

^e MFC-420 control module factory installed, set for 4 to 20 mA_{dc}, 1" (25 mm) stroke.

^f AK-42309-500 positive positioner may be ordered separately and field adjusted for other ranges. Order a VK4 valve assembly for factory-installed positive positioner.

^g AK-42309-500 positive positioner must be used with MK-6911 on 6" VB-8213. Order separately. May be field adjusted for other ranges. Order a VK4 valve assembly for factory-installed positive positioner.

^h May be field configured for 4-20 mA_{dc}.

Flow Characteristics

The flow curve shown in Figure-1 is representative of all sizes. All valve plugs have lower gain when nearly closed to enhance control at low demand. Two-way valves are nominally equal percentage and normally used for water and low pressure steam.

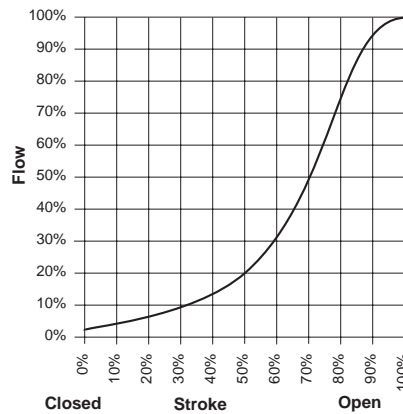

Figure-1 Typical Equal Percentage Flow Characteristics

Rangeability

Rangeability is the ratio of rated flow to the minimum controllable flow through the valve. The nominal rangeability for VB-8213 series valves is greater than 100:1.

Temperature/Pressure Ratings

See Figure-2 for temperature and pressure ratings. Consult the appropriate actuator General Instruction sheet for the effect of ambient temperatures on specific actuators. Ratings conform with published values and disclaimers.

VB-8213-0-5-P (Flanged Cast Iron Body)

Standards: ANSI B16.1-1993

Materials: ASTM A126-93 Class B

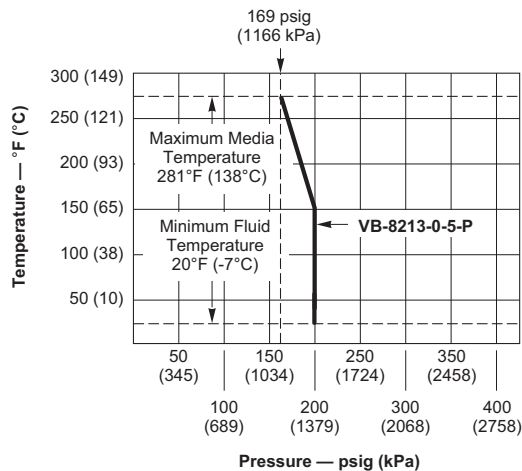

Figure-2 Temperature and Pressure Ratings for VB-8213 Series Valve Bodies

VALVE SIZING AND SELECTION

Water

Flow Coefficient (C_v)

Sizing a valve requires selecting a flow coefficient (C_v), which is defined as the flow rate in gallons per minute (gpm) of 60°F water that will pass through the fully open valve with a 1 psi pressure drop (Δp). It is calculated according to the formulas shown in C_v Equation for Water and C_v Equation for Steam.

Since the flow rate through the heat exchanger is usually specified, the only variable normally available in sizing a valve is the pressure drop. The following information can be used to determine what pressure drop to use in calculating a valve C_v. Using the calculated C_v, consult Table-4 or Table-5 to select the valve body with the nearest available C_v.

Caution: Be sure that the anticipated pressure drop across the valve will not exceed the close-off pressure rating and the maximum pressure differential rating listed in the *Vx-8xxx Selection Guide*, F-27199.

Two-position

Two-position control valves are normally selected “line size” to keep pressure drop at a minimum. If it is desirable to reduce the valve below line size, then 10% of “available pressure” (that is, the pump pressure differential available between supply and return mains with design flow at the valve location) is normally used to select the valve.

Proportional

Proportional control valves are usually selected to take a pressure drop equal to at least 50% of the “available pressure.” As “available pressure” is often difficult to calculate, the normal procedure is to select the valve using a pressure drop at least equal to the drop in the coil or other load being controlled (except where small booster pumps are used) with a minimum recommended pressure drop of 5 psi (34 kPa). When the design temperature drop is less than 60°F (33°C) for conventional heating systems, higher pressure drops across the valve are needed for good results (Table-3).

Table-3 Conventional Heating System

Design Temperature Load Drop °F (°C)	Recommended Pressure Drop ^a (% of Available Pressure)	Multiplier on Load Drop
60 (33) or More	50%	1 x Load Drop
40 (22)	66%	2 x Load Drop
20 (11)	75%	3 x Load Drop

^a Recommended minimum pressure drop = 5 psi (34 kPa).

Secondary Circuits with Small Booster Pumps: 50% of available pressure difference (equal to the drop through load, or 50% of booster pump head).

Water Table

See Table-4 for water capacity of VB-8213 series valves.

Table-4 Water Capacity in Gallons Per Minute for VB-8213 Series

Valve Body Part Number	C _v Rating	Differential Pressure (ΔP in psi)														
		1	2	3	4	5	6	7	8	9	10	15	20	25	30	35
VB-8213-0-5-12	56	56	79	97	112	125	137	148	158	168	177	217	250	280	307	331
VB-8213-0-5-13	85	85	120	147	170	190	208	225	240	255	269	329	380	425	466	503
VB-8213-0-5-14	145	145	205	251	290	324	355	384	410	435	459	562	648	725	794	858
VB-8213-0-5-15	240	240	339	416	480	537	588	635	679	720	759	930	1073	1200	1315	1420
VB-8213-0-5-16	370	370	523	641	740	827	906	979	1047	1110	1170	1433	1655	1850	2027	2189

C_v Equation for Water

$$C_v = \frac{gpm}{\sqrt{\Delta P}} \quad \Delta P = \left(\frac{gpm}{C_v} \right)^2 \quad gpm = C_v \sqrt{\Delta P}$$

Where:

C_v = Coefficient of flow.

gpm = Flow rate of water that will pass through fully open valve, measured in U.S. gallons per minute (60 °F (15.6 °C) water).

ΔP = Differential pressure (pressure drop), measured in psi.

Steam

Two-position

Two-position valves are normally sized using a minimum of 10% of inlet pressure (psig).

Proportional

Proportional control valves are normally sized using:

- For low pressure (15 psig or less), use ΔP of 80% of gauge inlet pressure.
- For steam pressures greater than 15 psig, use ΔP of 42% of absolute (gauge plus 14.7) inlet pressure.
- When the C_v required is between two valve sizes, select the larger size. Do not size steam valves using a pressure drop greater than 42% of the absolute inlet pressure.

Steam Table

See Table-5 for steam capacity of VB-8213 series valves.

Table-5 Steam Capacity in Pounds Per Hour for VB-8213 Series

Valve Body Part Number	C_v Rating	Differential Pressure (ΔP in psi)															
		2 psig Inlet		5 psig Inlet		10 psig Inlet		15 psig Inlet		20 psig Inlet		25 psig Inlet		30 psig Inlet		35 psig Inlet	
		0.2	1.6	0.5	4	1	8	1.5	12	2	14	2.5	16	3	18	3.5	20
VB-8213-0-5-12	56	305	826	520	1331	818	1942	1093	2448	1359	2860	1620	3271	1879	3683	2136	4094
VB-8213-0-5-13	85	463	1253	790	2021	1241	2947	1658	3716	2062	4341	2459	4965	2852	5590	3242	6214
VB-8213-0-5-14	145	790	2138	1348	3447	2118	5027	2829	6339	3518	7405	4195	8470	4865	9536	5531	10601
VB-8213-0-5-15	240	1308	3539	2231	5706	3505	8322	4683	10493	5823	12257	6943	14021	8053	15784	9156	17548
VB-8213-0-5-16	370	2016	5456	3439	8796	5404	12830	7219	16177	8977	18896	10704	21615	12415	24334	14115	27053

C_v Equation for Steam

$$C_v = \frac{Q \cdot K}{3 \sqrt{\Delta P \cdot P_2}} \quad Q = \frac{3 C_v \sqrt{\Delta P \cdot P_2}}{K}$$

Where:

C_v = Coefficient of flow.

Q = Flow rate of steam that will pass through fully open valve, measured as pounds per hour of steam.

ΔP = Differential pressure (pressure drop), measured in psi.

P2 = Outlet pressure, measured in psia (absolute pressure). P2 = Inlet pressure + 14.7 – ΔP.

K = 1 + (0.0007 x °F superheat). K = 1 for saturated steam.

Cavitation Limitations on Valve Pressure Drop

A valve selected with too high a pressure drop can experience erosion of discs and/or wire drawing of the seat. In addition, cavitation can cause noise, damage to the valve trim (and possibly the body), and choke the flow through the valve.

Do not exceed the maximum differential pressure (pressure drop) for the valve selected.

The following formula can be used on higher-temperature water systems, where cavitation could be a problem, to estimate the maximum allowable pressure drop across the valve:

$$P_m = 0.5 (P_1 - P_v)$$

Where:

P_m = Maximum allowable pressure drop

P_1 = Absolute inlet pressure (psia)

P_v = Absolute vapor pressure (psia) (refer to Table-6)

Note: Add 14.7 psi to the gauge supply pressure to obtain the absolute pressure value.

For example, if a valve is controlling 200°F water at an inlet pressure of 18 psig, the maximum pressure drop allowable would be:

$$P_m = 0.5 [(18 + 14.7) - 11.53] = 10.6 \text{ psi}$$

(Vapor pressure of 200°F water is 11.53 psi.)

Therefore, if the pressure drop for this valve is less than 10.6 psi, cavitation should not be a problem.

Systems where cavitation is shown to be a problem can sometimes be redesigned to provide lower inlet velocities. Valves having harder seat materials should be furnished if inlet velocities cannot be lowered.

Table-6 Vapor Pressure of Water

Water Temp. (°F)	Vapor Pressure (psia)	Water Temp. (°F)	Vapor Pressure (psia)	Water Temp. (°F)	Vapor Pressure (psia)	Water Temp. (°F)	Vapor Pressure (psia)
40	0.12	90	0.70	140	2.89	190	9.34
50	0.18	100	0.95	150	3.72	200	11.53
60	0.26	110	1.28	160	4.74	210	14.12
70	0.36	120	1.69	170	5.99	220	17.19
80	0.51	130	2.22	180	7.51	230	20.78

Additional Valve Sizing Information

For additional valve sizing information, see the *Vx-8xxx Selection Guide*, F-27199.

INSTALLATION

Inspection

Inspect the package for damage. If damaged, notify the appropriate carrier immediately. If undamaged, open the package and inspect the device for obvious damage. Return damaged products.

Requirements

- Tools (not provided): Wrenches.
- Training: Installer must be a qualified, experienced technician
- Appropriate accessories

Caution:

- Install the valve with the flow in the direction of the flow arrow (“A” port is the inlet and “AB” port is the outlet). A label on the side of the valve provides port identification and a flow arrow.
 - Do not exceed the ratings of the device.
 - Avoid locations where excessive moisture, corrosive fumes, or vibration are present.
-

Mounting

1. The valve should be mounted in a weather-protected area in a location that is within the ambient limits of the actuator. When selecting a location, allow sufficient room for valve linkage, actuator, and other accessories and for service of the product.
2. The preferred mounting position for the valve is with the valve stem vertical above the valve body. Avoid mounting the valve so that the valve stem is below horizontal.
3. On steam applications, the valve stem should be 45° from vertical.
4. The valve must be piped with the “A” port as the inlet and the “AB” port as the outlet.

Flanged Valve Bodies

The VB-8213-0-5-P series flanged valve bodies conform to American Standard 125 psi Cast Iron Pipe Flanges. The companion flanges (not provided) should be the same specification as the valve. The 125 psi flanges have plain flat faces and should not be bolted to a raised faced flange.

1. All parts should be clean to assure tight seals.
2. The pipe with the companion flanges installed should be properly supported and aligned. Be sure the companion flange is flush with the face of the valve body flange and lined up squarely.
3. Use a gasket material (not provided) that is recommended for the medium being handled.

Caution: Do not apply pipe dope to the valve flange, gasket, or companion flange.

4. Figure-3 shows the proper way a flanged valve should be mounted. See Figure-6 and Table-9 for flange and flange bolt details.

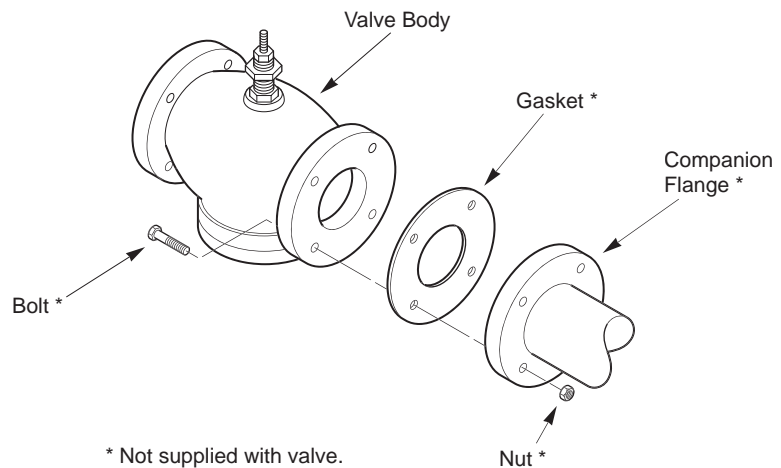

Figure-3 Installation of Flanged End Valves

CHECKOUT

1. Make sure the valve stem operates smoothly before installing the valve linkage and the actuator. Initial breakaway force can be expected.
2. If the stem does not operate smoothly, it may indicate that the valve stem was bent by rough handling. These conditions may require valve replacement.
3. After the piping is under pressure, check the valve body and the connections for leaks.
4. After the valve linkage and the actuator are installed, check their operation.

MAINTENANCE & FIELD REPAIR

Regular maintenance of the total system is recommended to assure sustained performance. See Figure-4 and Table-7 for maintenance kits and their part numbers.

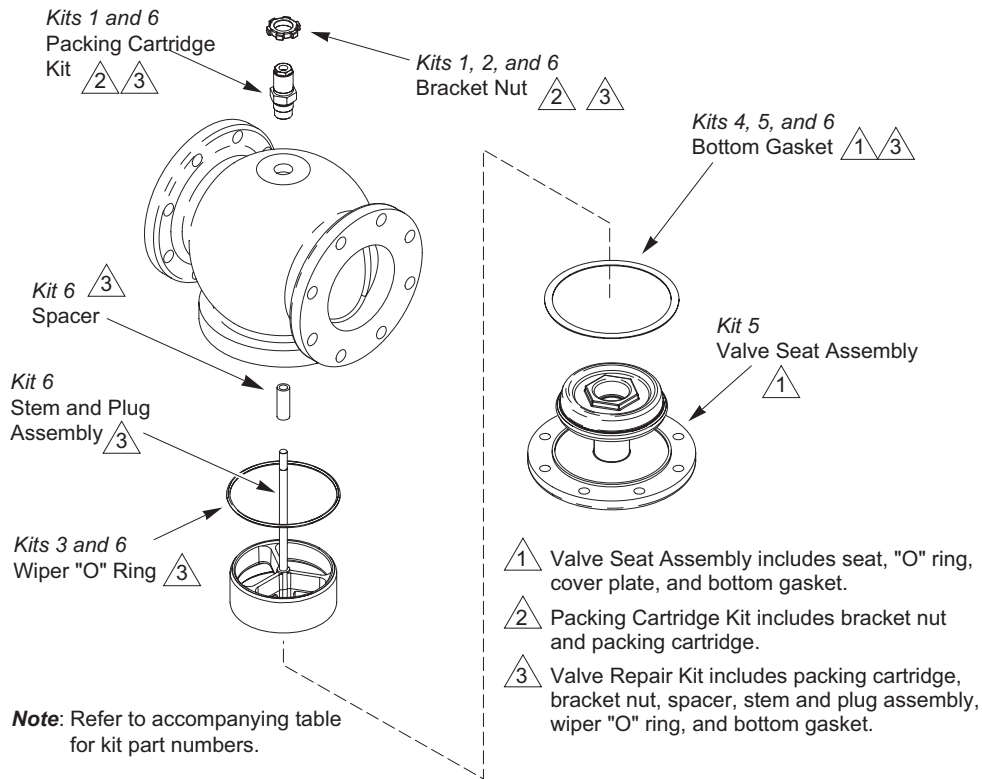

Figure-4 VB-8213 2-1/2" to 6" Repair Parts

Table-7 Maintenance Kits for VB-8213 Valves

Valve Body Part Number	Size	Kit 1	Kit 2	Kit 3	Kit 4	Kit 5	Kit 6
		Packing Cartridge	Bracket Nut	Wiper "O" Ring	Bottom Gasket	Valve Seat Assembly	Valve Repair Kit
VB-8213-0-5-12	2-1/2"	YBA-652-2	OYBB-225	NYBA-8303-104-0-12	BYRZ-13-12	YBA-821-101-0-12	RYB-821-12
VB-8213-0-5-13	3"	YBA-652-2	OYBB-225	NYBA-8303-104-0-13	BYRZ-13-13	YBA-821-101-0-13	RYB-821-13
VB-8213-0-5-14	4"	YBA-652-2	OYBB-225	NYBA-8303-104-0-14	BYRZ-13-14	YBA-821-101-0-14	RYB-821-14
VB-8213-0-5-15	5"	YBA-652-2	OYBB-225	NYBA-8303-104-0-15	BYRZ-13-15	YBA-821-101-0-15	RYB-821-15
VB-8213-0-5-16	6"	YBA-652-2	OYBB-225	NYBA-8303-104-0-16	BYRZ-13-16	YBA-821-101-0-16	RYB-821-16



Caution: Before loosening or removing packing cartridge, depressurize valve to zero psi gauge (0 psig). If the packing cartridge is loosened or removed while there is pressure in the valve, valve packing may blow out with the potential of bodily injury and/or water/steam damage.



Caution: EPDM components are not compatible with petroleum-based compounds. Use of such compounds will damage packings and seat rings and necessitate replacement of packing cartridge and/or stem and plug assembly.

Water System Maintenance

All heating and cooling systems are susceptible to valve and system problems caused by improper water treatment and system storage procedures. These guidelines are provided to help avoid valve and water system problems resulting from improperly treated water or storage procedures in cooling and hot water systems, and to obtain maximum life from TAC valves.

Durability of valve stems and packings is dependent on maintaining non-damaging water conditions. Inadequate water treatment or filtration, not in accordance with chemical supplier/ASHRAE handbook recommendations, can result in corrosion, scale, and abrasive particle formation. Scale and particulates can result in stem and packing scratches and can adversely affect packing life and other parts of the hydronic system.

To maintain non-damaging conditions, follow these guidelines:

- Clean the system prior to start up. Use a nitrite or molybdate-based treatment program.
- Use filtration equipment where needed.
- Properly store off-line systems and monitor water treatment results using corrosion test coupons.
- Follow the advice of a water treatment professional.
- Consult *EN-205 Water System Guidelines*, F-26080, for further details.

DIMENSIONAL DATA

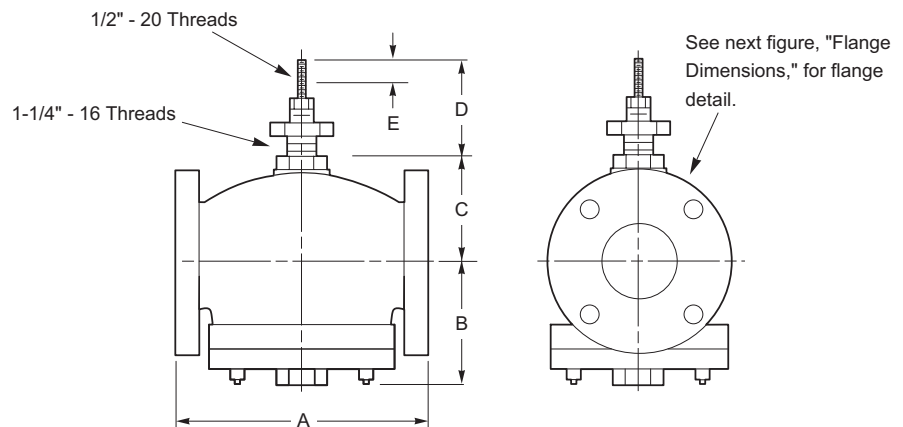

Figure-5 Typical of VB-8213-0-5-P 2-1/2" to 6" Valve Bodies

Table-8 Dimensions for VB-8213 Series Valves (Figure-5)

Part Number	Valve Size	Dimensions in Inches (mm)				
		A	B	C	D (Stem Down)	E ^a (Nominal Stroke)
VB-8213-0-5-12	2-1/2"	8-9/16 (217)	4 (102)	4-1/8 (105)	3-1/4 (83)	1 (25)
VB-8213-0-5-13	3"	9-1/2 (241)	4-5/8 (117)	4-3/8 (111)		
VB-8213-0-5-14	4"	11-1/2 (292)	5-1/2 (140)	5-1/16 (129)		
VB-8213-0-5-15	5"	13 (330)	6-15/16 (176)	5-9/16 (141)		
VB-8213-0-5-16	6"	14 (356)	7-1/2 (190)	6-3/8 (162)		

^a Nominal stroke for rated flow.

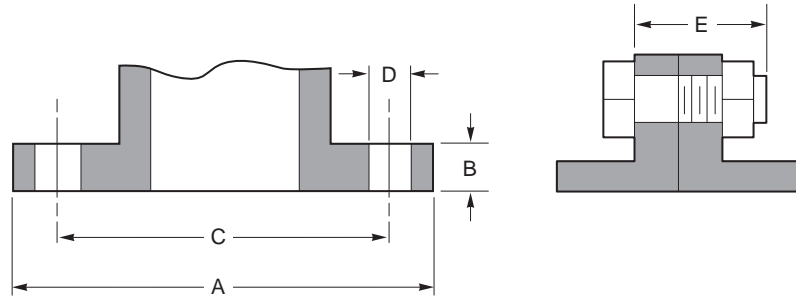

Figure-6 Flange Dimensions

Table-9 Flange Detail for American Standard 125 psi Cast Iron Pipe Flanges (Figure-6)

Nominal Pipe Size	Flanges		Drilling		Bolting		Length of Machine Bolts E
	Flange Diameter A	Flange Thickness B	Diameter of Bolt Circle C	Diameter of Bolt Holes D	Number of Bolts	Diameter of Bolts	
2-1/2"	7"	11/16"	5-1/2"	3/4"	4	5/8"	2-1/2"
3"	7-1/2"	3/4"	6"				
4"	9"	15/16"	7-1/2"		7/8"	8	3/4"
5"	10"		8-1/2"				
6"	11"	1"	9-1/2"				

Copyright 2006, TAC
 All brand names, trademarks and registered trademarks are the property of their respective owners. Information contained within this document is subject to change without notice.

TAC
 1354 Clifford Avenue
 P.O. Box 2940
 Loves Park, IL 61132-2940

F-27193-3



www.tac.com

