

AV-822

Adapter Kit Schneider Electric Forta U-Bolt Style Actuators to 2½...6" VB-8xxx/9xxx Series Valves

Application

The AV-822 adapter kit enables mounting of Schneider Electric Forta M1500 actuators on 2-1/2" to 6" VB-8xxx series and VB-9xxx series valves or Forta M800A actuators on VB-9xxx 2-1/2 to 4" series valves or M900Ax on 2-1/2 to 4" VB-8xxx series and VB-9xxx series valves.

▼ **WARNING**

Depressurize the valve before removing the existing actuator and linkage and check integrity of the valve stem and plug by moving the stem up and down. If the valve stem and plug have been damaged, stem may blow out under pressure and cause injury and equipment damage.

▼ **CAUTION**

Do not remove the packing cap from the valve.

NOTE

For Barber-Colman 3/8" stem valves, use AV-813 adapter kit with this kit to adapt the 3/8"-24 stem threads to 1/2"-20 actuator threads.

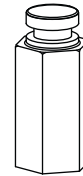
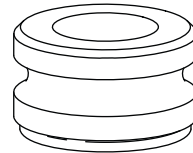

Applicable Literature

- *Valve Catalog, F-27414*
- *M400A, M800A, M1500A Forta Non Spring Return Globe Valve Actuator General Instructions, F-27599*
- *M900Ax Forta Spring Return Globe Valve Actuator Installation Instructions, F-27683*

Tools Needed

- 5/8" wrench
- 3/4" wrench
- Pipe wrench

Installation

Follow the steps below.

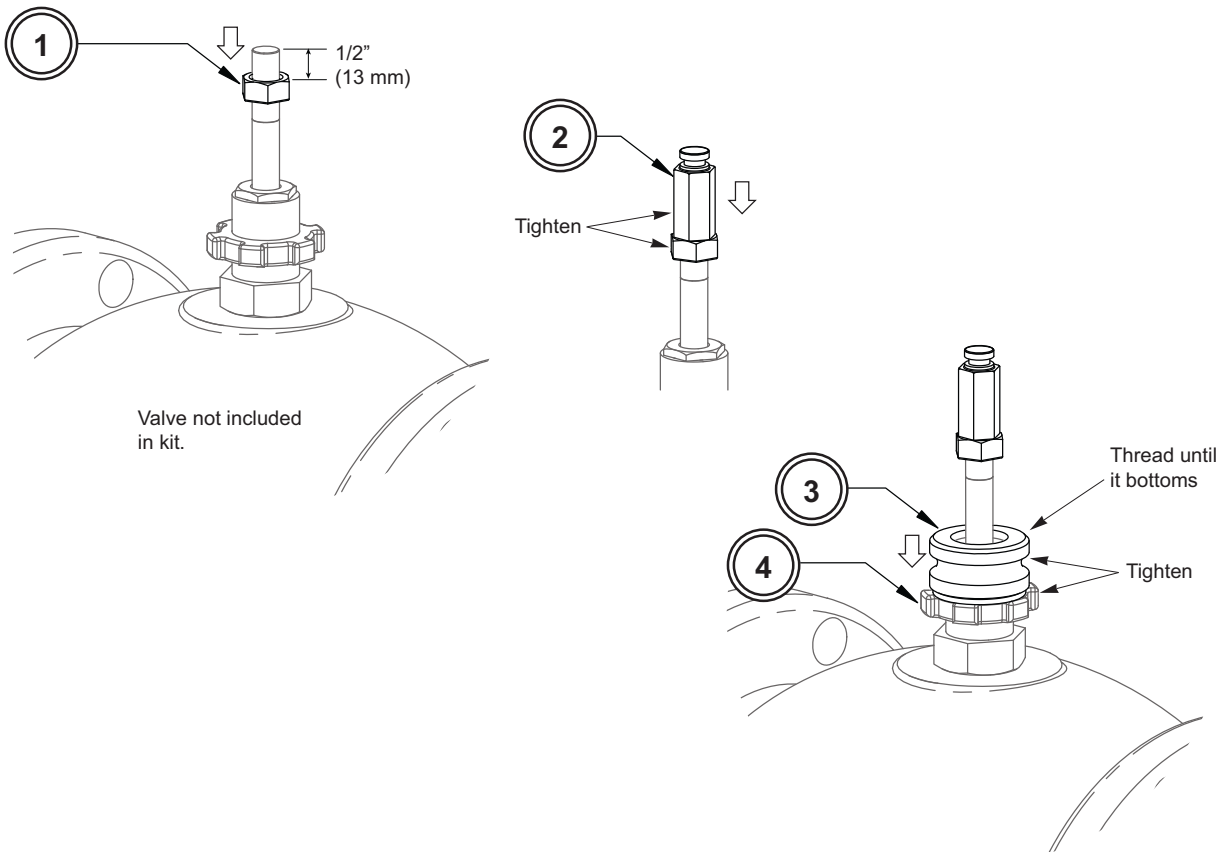

Remove the AV-822 components from the bag and install the jam nut (1) such that there is 1/2" of exposed threads above the nut. Install the stem extension (2) until it makes contact with the jam nut and tighten using 5/8" and 3/4" wrenches. Thread the valve nut (4) down until a minimum of 1/2" of bonnet threads are exposed, then install the bonnet adapter (3) to the valve body bonnet and thread down until it bottoms on the bonnet. Firmly hold the bonnet adapter (3) and tighten the valve nut (4) with the pipe wrench.

After the AV-822 adapter is installed, install the selected actuator and linkage (if required) according to the actuator installation instructions.