

Application

The AV-814 adapter kit enables mounting of Schneider Electric pneumatic and SmartX actuators (electric/electronic) onto 1/2" to 2" Siemens Flowrite 599 Series 3/4" stroke globe valves using a suitable Schneider Electric actuator linkage.

Consult the *AV-8xx Series Competitive Globe Valve Adapters Selection Guide*, F-27470, for Schneider Electric actuators.

WARNING:

- The AV-814 adapter kit is to be used **only** with the Schneider Electric actuators shown in the *AV-8xx Series Competitive Globe Valve Adapters Selection Guide*, F-27470. The use of other actuators is not acceptable due to actuator stroke and valve stem force limitations.
- For proper operation, the stroke of the Schneider Electric actuator selected must be equal to or greater than that of the Siemens valve body
- Depressurize the valve before removing the existing actuator and linkage and check integrity of the valve stem and plug by moving the stem up and down. If the valve stem and plug have been damaged, stem may blow out under pressure and cause injury and equipment damage.

CAUTION:

- Siemens valves with 1/2" stroke or threaded stems require different kits for their specific bonnet configuration.
- Do not remove the packing cap from the valve.

Applicable Literature

- *AK-42309-500 Positive Positioner Relay General Instructions*, F-22909
- *AV-430 Valve Linkage Kit for MK-68x1 Pneumatic Actuators General Instructions*, F-19072
- *AV-8xx Series Competitive Globe Valve Adapters Selection Guide*, F-27470
- *AV-7800 Pneumatic Actuator Valves Linkage Kit for MK-2690 and 3/4" Stroke Valves General Instructions*, F-27432
- *MK-2690 Series Pneumatic Valve Actuator General Instructions*, F-13893
- *MK-68xx Series Pneumatic Valve Actuator General Instructions*, F-13895
- *Mxx1-720x Series Two-Position, Floating, and Proportional Actuators General Instructions*, F-27120
- *Electric-Electronic Products Catalog*, F-27382
- *Pneumatic Products Catalog*, F-27383

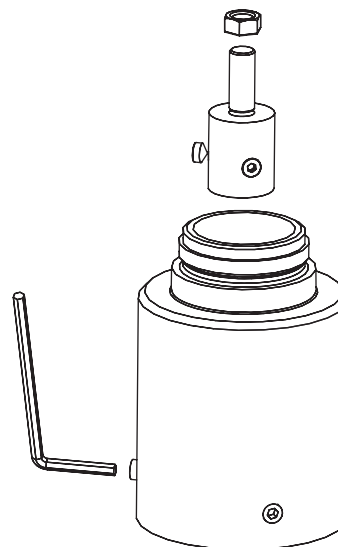

Tools Needed

- TOOL-118 hex wrench (provided in kit)

Assembly Instructions

Follow the steps below.

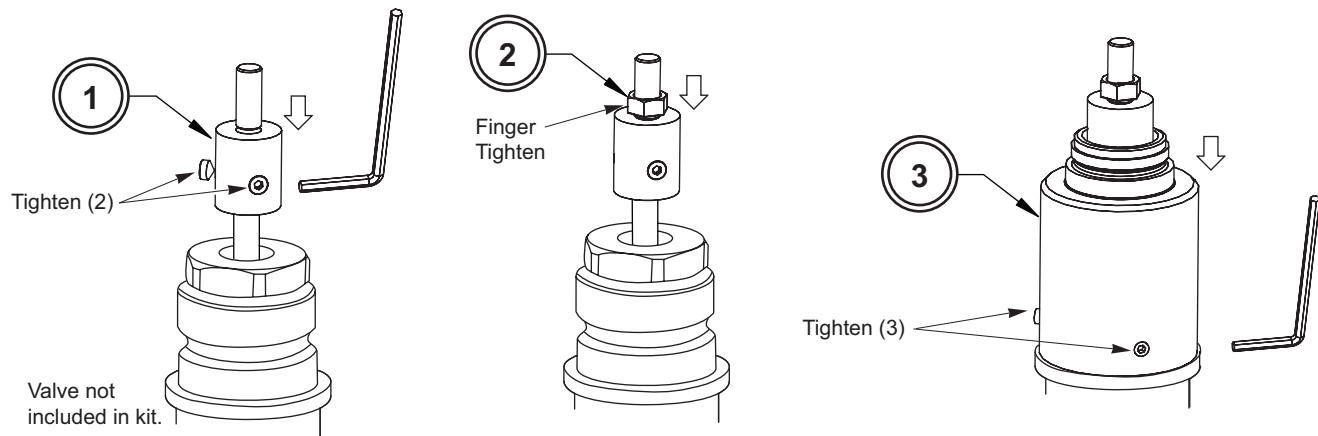

After the AV-814 adapter is installed, install the selected actuator and linkage (if required) according to the actuator installation instructions.

Maintenance Parts

All valve body maintenance parts must be obtained from the manufacturer, Siemens.

Actuator and linkage maintenance parts may be obtained from Schneider Electric.