

---

# **TAC I/A Series MicroNet BACnet Smoke-Control Systems Manual**

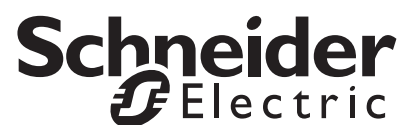



---

# **TAC I/A Series MicroNet BACnet Smoke-Control Systems Manual**

---

On October 1st, 2009, TAC became the Buildings Business of its parent company Schneider Electric. This document reflects the visual identity of Schneider Electric, however there remains references to TAC as a corporate brand in the body copy. As each document is updated, the body copy will be changed to reflect appropriate corporate brand changes.

All brand names, trademarks and registered trademarks are the property of their respective owners. Information contained within this document is subject to change without notice.

**Schneider Electric** 1354 Clifford Avenue, P.O. Box 2940, Loves Park, IL 61132-2940, USA 1-888-444-1311 [www.schneider-electric.com/buildings](http://www.schneider-electric.com/buildings)

F-27419-2

September 2010 ptm

© 2010 Schneider Electric. All rights reserved.

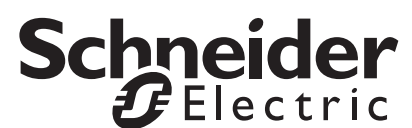

---

# Table of Contents

## Preface

---

Purpose of this Manual .....	ix
Abbreviations Used in this Manual .....	x
Definitions .....	xi
Applicable Standards .....	xii
Conventions Used in this Manual .....	xiii
Manual Summary .....	xiii

## Chapter 1

### Introduction

---

What is the UL 864 UUKL/UUKL7 Listing? .....	1-1
What Was Required to Gain the UL 864 UUKL/UUKL7 Listing? .....	1-2
Hardware .....	1-2
Software .....	1-2
What are Your UL 864 UUKL/UUKL7 Responsibilities? .....	1-3
Explanation of Smoke-Control Systems .....	1-4
Building Pressurization .....	1-4
Dedicated and Nondedicated Systems .....	1-4
Basic System Types .....	1-5
Shaft Protection .....	1-5
Floor Protection .....	1-6
HVAC Equipment .....	1-7
Smoke-Control System Activation .....	1-7
Response Time .....	1-8
Firefighter's Smoke Control Station .....	1-8
Control Sequence for Stair Pressurization Systems .....	1-9
Control Sequence for Zoned Smoke-Control Systems .....	1-9
Automatic Response To Multiple Signals .....	1-10
Maintaining System Integrity .....	1-10
Smoke-Control System Schedule .....	1-11
Conclusion .....	1-12

**Chapter 2 High-rise Smoke Control**

---

Purpose . . . . . 2-13

Sequence of Operation . . . . . 2-13

    Normal HVAC Control . . . . . 2-13

    Smoke Control Sequences . . . . . 2-17

Smoke-Control System Configuration Schedule . . . . . 2-20

Firefighter’s Smoke Control Station (FSCS) . . . . . 2-22

    Location and Access . . . . . 2-22

    Physical Arrangement . . . . . 2-22

    Status Indicators . . . . . 2-22

    Audible Annunciation . . . . . 2-23

    Control Capability . . . . . 2-23

    Additional Control Requirements . . . . . 2-23

System Topologies . . . . . 2-25

    MNB-1000 Controllers . . . . . 2-25

    Ethernet/IP Infrastructure . . . . . 2-25

        Wiring Requirements . . . . . 2-26

        Central System Interface and Overlay Devices . . . . . 2-26

    MNB-Vx Topology . . . . . 2-28

        MS/TP Bus Requirements . . . . . 2-28

    MNB-1000 Interface to FSCS . . . . . 2-30

    Fire Alarm Panel Interface and Remaining System Topology . . . . . 2-32

Comments . . . . . 2-33

**Chapter 3 Warehouse Smoke Control**

---

Purpose . . . . . 3-35

Sequence of Operation . . . . . 3-35

    Normal HVAC Control . . . . . 3-35

    Smoke Control Sequences . . . . . 3-36

Smoke-Control System Configuration Schedule . . . . . 3-39

Firefighter’s Smoke Control Station (FSCS) . . . . . 3-40

System Topologies . . . . . 3-40

    Warehouse Building Layout . . . . . 3-40

    Ethernet/IP Infrastructure . . . . . 3-41

        Wiring Requirements . . . . . 3-41

        Central System Interface and Overlay Devices . . . . . 3-41

    MNB-1000 Interface to FSCS . . . . . 3-43

    Fire Alarm Panel Interface . . . . . 3-43

Comments . . . . . 3-46

**Chapter 4 Campus Smoke Control**

---

Purpose . . . . . 4-47

Sequence of Operation . . . . . 4-47

    Normal HVAC Control . . . . . 4-47

    Smoke Control Sequences . . . . . 4-49

Smoke-Control System Configuration Schedule .....4-53  
 Firefighter’s Smoke Control Station (FSCS) .....4-55  
 System Topologies .....4-55  
     Campus Topology with MNB-1000 Controllers .....4-55  
     Ethernet/IP Infrastructure .....4-55  
         Wiring Requirements .....4-56  
     Central System Interface and Overlay Devices .....4-56  
     MNB-V2 Topology .....4-59  
         MS/TP Bus Requirements .....4-59  
     MNB-1000 Interface to FSCS .....4-61  
     Fire Alarm Panel Interface .....4-63  
 Comments .....4-63

**Chapter 5 Restrictions and General Comments**

Purpose .....5-65  
 Restrictions .....5-65  
     Software Access Levels .....5-65  
     System Overrides .....5-66  
     Approved Fire Alarm Panels .....5-67  
     Approved Firefighter’s Smoke Control Stations .....5-67  
     Approved IP/Ethernet Infrastructure Devices .....5-71  
     Approved MS/TP Repeaters .....5-72  
     Use of MNB-1000 IP Switch Feature .....5-74  
     Dedicated Supply Air Dampers .....5-74  
     Class 2 Powered Devices .....5-75  
     EIA-485 Termination and Bias Resistors .....5-75  
     System Self-Tests .....5-75  
     Transformers .....5-76  
     Enclosures .....5-76  
     Wiring .....5-77  
     Hardware and Firmware Upgrade Process Requirements .....5-78  
     UL-1459 (Abnormal Overvoltage) Compliance .....5-78  
 General Comments .....5-78  
     FSCS Requirement .....5-78  
     MNB-1000 Using ADI ModBus Interface .....5-78  
     Job Estimating .....5-78  
     Spare I/O Points .....5-80  
     Lost Communications .....5-80  
     Use of BACnet Priority Structures .....5-83  
     Use of Transient Suppressor on MNB-300 DO .....5-84  
     Multiple MNB-V1/-V2 Controllers for Pressure Summation .....5-85  
     VAV Zone Pressure or Position Indication .....5-85  
     I/A Series BACnet Applications .....5-85

*Appendix A*    **Additional Information**

---

MicroNet BACnet Controllers .....	A-1
Common Controller Features .....	A-1
MNB-300 Unitary Controller .....	A-2
MNB-V1, MNB-V2 VAV Controllers .....	A-4
MNB-1000 Plant Controller .....	A-6
Input and Output Specifications .....	A-8
Universal Inputs .....	A-8
Universal Outputs .....	A-9
Digital Inputs .....	A-9
Digital Outputs, Triac .....	A-10
20 Vdc Output .....	A-12
Inputs from MN-Sx MicroNet Sensor .....	A-12
Velocity Pressure Input .....	A-13
Communication Circuits .....	A-14
Intermixing of Cables .....	A-14
Sensor Link (S-Link) Wiring .....	A-15
MicroNet MS/TP Network Wiring .....	A-15
ADI Wiring .....	A-16
Ethernet Network Wiring .....	A-16
MicroNet MS/TP Network Wiring .....	A-16
Cable Specifications .....	A-17
Approved Cable Types .....	A-17
Signaling Line Circuits .....	A-18
ADI Wiring Specifications .....	A-18
I/O Wiring .....	A-19
Intermixing of Wiring .....	A-19
Universal Inputs (UI), Universal Outputs (UO), and Digital Inputs (DI)	A-19
A-19	
Power Supply Wiring .....	A-20

*Appendix B*    **Approved Part Numbers**

---

Controllers .....	B-1
Final Assemblies .....	B-1
Subassemblies .....	B-1
Transformers .....	B-2
Final Assembly .....	B-2
Accessories .....	B-3
Subassemblies .....	B-3
Enclosures .....	B-3
Third Party UUKL Listed Products .....	B-4

*Appendix C*    **Applicable Documentation**

---

Installation Instructions .....	C-1
Manuals .....	C-2
Release Notes .....	C-2



*Appendix D*    **References**

---

Other Reference Publications . . . . . D-1



# Preface

## Purpose of this Manual

This manual is intended for use by qualified, authorized engineers and technicians who are responsible for meeting a UL 864 UUKL/UUKL7 project specification. The specification, created by the smoke-control system designer, should have already considered the selected mechanical equipment design. Proper duct sizing and layout, motor/blower selection, and damper selection must be completed by the smoke-control system designer to provide the planned smoke-control pressurization under all possible expected environmental (wind, weather, etc.) and building (door, elevator hoistway, leakage, system response, stairwell, occupied mode, etc.) conditions.

---

### Note:

- UUKL7, which is referred to throughout this manual, is the Category Code Number (CCN) for smoke-control system equipment certified for use in Canada.
- Throughout this manual, all references to UUKL are intended to refer to UUKL7 also (i.e. UUKL/UUKL7).
- Throughout this manual, all references to the MNB-V1 equally apply to the MNB-V1-2 and all references to the MNB-V2 equally apply to the MNB-V2-2.

---

This manual's purpose is to provide the fundamentals for the controls engineer and technicians to meet a properly designed smoke-control specification. General topologies, specific requirements, and exceptions to our published literature that are required by Underwriters Laboratories, Inc. for UL 864 UUKL/UUKL7 are provided. This manual *does not* provide guidelines for mechanical system selection and design. Recognized smoke pressurization program models are available for this purpose. This manual also does not cover all installation and wiring requirements for TAC I/A Series<sup>®</sup> MicroNet<sup>™</sup> BACnet<sup>™</sup> controllers. It must be used along with the *I/A Series MicroNet BACnet Wiring, Networking, and Best Practices Guide*, F-27360, and applicable I/A Series BACnet controller installation instructions.

---

## Abbreviations Used in this Manual

ADA	Americans for Disabilities Act
ADI	Automation Displays, Inc.
AHJ	Authority Having Jurisdiction
AHU	Air Handling Unit
AI	Analog Input
CCN	Category Code Number (UL)
CFM	Cubic Feet per Minute
DI	Digital Input
DO	Digital Output
EOL	End of Line (Termination)
EOL JPR	End-of-Line Jumper (EOL resistor and/or bias resistor engaged through on-board jumper)
FAP	Fire Alarm Panel
FSCS	Firefighter's Smoke Control Station
HVAC	Heating-Ventilating-Air Conditioning
I/O	Input/Output
IP	Internet Protocol
ITE	Information Technology Equipment
JPR	Jumper
LAN	Local Area Network
LED	Light Emitting Diode
NEC	National Electrical Code
NFPA	National Fire Protection Association
N.O.	Normally Open
NW	Network
O.A.	Outside Air
UI	Universal Input
UL	Underwriters Laboratories, Inc.
VAV	Variable Air Volume
WP Tech	WorkPlace Tech Tool



Smoke Control Zone	A space within a building enclosed by smoke barriers, including the top and bottom, that is part of a zoned smoke-control system.
Smoke Exhaust System	A mechanical or gravity system intended to move smoke from the smoke zone to the exterior of the building, including smoke removal, purging, and venting systems, as well as the function of exhaust fans utilized to reduce the pressure in a smoke zone.
Smoke Zone	The smoke-control zone in which the fire is located.
Stairwell Pressurization System	A type of smoke-control system in which stair shafts are mechanically pressurized, with respect to the fire area, with outdoor air to keep smoke from contaminating them during a fire event.
Tenable Environment	An environment in which smoke and heat is limited or otherwise restricted to maintain the impact on occupants to a level that is not life threatening.
Zoned Smoke-Control System	A smoke-control system that includes smoke exhaust for the smoke zone and pressurization for all contiguous smoke-control zones.

## Applicable Standards

This manual should be used in conjunction with the following standards which apply to the Schneider Electric UL 864, 9th ed. Listing.

### Underwriters Laboratories (UL) Standards

- UL 864, 9th ed. (2003) *Control Units for Fire Protective Signaling Systems*
- UUKL *Smoke-Control System Equipment (Category under UL 864)*
- CAN/ULC-S527-99 *Standard For Control Units For Fire Alarm Systems*
- ULC/ORD-C100-92 *Smoke Control System Equipment*
- UUKL7 *Category for Smoke-Control System Equipment Certified for Use in Canada*

### National Fire Protection Association (NFPA) Standards

- NFPA 70 *National Electrical Code*
- NFPA 72 *National Fire Alarm Code, 2007 Edition*  
This standard covers the application, installation, performance, and maintenance of protective signaling systems and their components.
- NFPA 92A *Standard for Smoke-Control Systems Utilizing Barriers and Pressure Differences, 2009 Edition*

This standard covers the design, installation, testing, operation, and maintenance of new and retrofitted mechanical air conditioning and ven-

tilation systems for the purpose of controlling smoke.

- NFPA 92B *Standard for Smoke Management Systems in Malls, Atria, and Large Areas, 2005 Edition*

This standard provides technical data relevant to the design, installation, testing, operation, and maintenance of new and retrofitted smoke management systems. It is intended for buildings having large volume spaces, for the management of smoke within the space where the fire exists, or between spaces not separated by smoke barriers.

#### Other Standards

- *Canadian Electrical Code, Part 1*

## Conventions Used in this Manual

The following conventions apply to this printed manual:

- Menu commands appear in **bold**.  
Example — On the Special menu, point to **Security**, then click **Log On**.
- Italics is used for *emphasis* in a statement, such as:  
If maximum closed switch voltage is not more than 1.0 V *and* minimum open switch voltage is at least 4.5 V, then solid state switches may be used for a UI or a DI.  
It is also used when referring to a document, such as:  
Refer to the *WorkPlace Tech Tool 5.x Engineering Guide Supplement*, F-27356.

#### Acrobat (PDF) Conventions

If you are reading this manual online in Adobe® Acrobat® (.PDF file format), numerous hypertext links exist, both in normal black text and in blue text.

- Hypertext links in this document include all entries in the Table of Contents, as well as cross-references within the body text. For ease of recognition, cross-reference links within the body text appear in blue type, for example [Manual Summary](#). A link is indicated whenever the mouse pointer changes to a hand with a pointing finger.
- When viewing this guide with Adobe Acrobat, you can display various “bookmark” links on the left side of your screen by choosing “Bookmarks and Page” from the “View” menu. As with the links described above, these “bookmark” links will also cause the mouse pointer to change to a hand with a pointing finger.

## Manual Summary

This manual contains five chapters and two appendices.

#### Chapter 1 - Introduction

This chapter explains the UL 864 UUKL/UUKL7 Listing and defines various terms related to Smoke-Control Systems.

#### Chapter 2 - High-rise Smoke Control

This chapter provides application guidelines for using I/A Series MicroNet BACnet controllers in a five-floor, high-rise office building that requires the UL 864 UUKL/UUKL7 Listing for Smoke-Control Systems.

---

### **Chapter 3- Warehouse Smoke Control**

This chapter provides application guidelines for using I/A Series MicroNet BACnet controllers in a single-story warehouse building that requires the UL 864 UUKL/UUKL7 Listing for Smoke-Control Systems.

### **Chapter 4 - Campus Smoke Control**

This chapter provides application guidelines for using I/A Series MicroNet BACnet controllers in a large campus with multiple buildings that require the UL 864 UUKL/UUKL7 Listing for Smoke-Control Systems.

### **Chapter 5 - Restrictions and General Comments**

This chapter lists any restrictions associated with the application of I/A Series MicroNet BACnet controllers to UL 864 UUKL/UUKL7 Smoke-Control Systems. This chapter also includes general comments that may provide additional insight or flexibility during the engineering process.

### **Appendix A - Additional Information**

Appendix A presents additional information related to the wiring of an I/A Series MicroNet BACnet Smoke-Control System.

### **Appendix B - Approved Part Numbers**

Appendix B lists the part numbers of all I/A Series MicroNet BACnet equipment that have been UL 864 UUKL/UUKL7 listed.

### **Appendix C - Applicable Documentation**

Appendix C lists, by F-number, applicable documentation that is required to install, apply, engineer, operate, and troubleshoot I/A Series MicroNet BACnet and related equipment.

### **Appendix D - References**

Appendix D lists additional reference documents that are relevant to the design of Smoke-Control Systems.



---

# Chapter 1

## Introduction

Schneider Electric has worked with Underwriters Laboratories, Inc. to gain the UL 864 UUKL/UUKL7 listing. This UL listing involves testing both hardware and software for reliability by Underwriters Laboratories, Inc. as it pertains to this standard and sub-category.

### What is the UL 864 UUKL/UUKL7 Listing?

According to Underwriters Laboratories, the UL 864 UUKL/UUKL7 is a category that has been established for Smoke-Control System Equipment. “The products covered by this category are intended to be installed in conjunction with heating-ventilating-air conditioning (HVAC) equipment to form a system for controlling the flow of smoke in a building during a fire condition in accordance with Smoke-Control Systems, NFPA 92A or 92B.”<sup>1</sup> Additionally, according to Underwriters Laboratories (UL), smoke-control equipment is assigned one or more of the following attributes:

---

**Note:** Schneider Electric is listed for all of the following UUKL attributes.

---

1. Operation

Manual—Activation of the smoke-control system occurs as a result of the intervention of an authorized person.

Automatic—Activation of the smoke-control system occurs as a result of an alarm condition from a fire detection device, such as a smoke detector or heat detector, or fire alarm control unit.

2. Type

Nondedicated—A system which provides the building HVAC function under normal conditions and provides a smoke-control objective during a fire alarm condition.

Dedicated—A system which is normally inactive and is used exclusively for the purpose of smoke control.

3. Use

Stairwell—Configuration of equipment which provides pressurizing of stairwells for the purpose of maintaining a tenable environment for building egress.

---

1. Underwriters Laboratories, *Heating, Cooling, Ventilating, Cooking and Food Safety Equipment Directory 2006*.

Zoned Smoke Control—A configuration which provides the exhausting of the smoke area and pressurizing all of the other contiguous areas of the building.”<sup>2</sup>

The design of an overall smoke-control system is a complete system engineered to the particular installation. The interconnection of the smoke-control equipment to the HVAC equipment, and to other system equipment, is intended to be in accordance with a specific installation diagram that is generated by either the smoke-control equipment listee or by another responsible party.

In practice, Schneider Electric, as a UL Smoke Control Equipment Listee, and its associated field offices do not design the smoke-control system. Rather, the Schneider Electric field office works closely with the smoke-control system designer to develop the interface between the controls and equipment supplied by Schneider Electric and the mechanical equipment that provides smoke-control pressurization. The Schneider Electric field office then generates the control system installation diagrams based on the total smoke-control system design.

## What Was Required to Gain the UL 864 UUKL/UUKL7 Listing?

UL 864 UUKL/UUKL7 testing has two basic elements: hardware and software. Each element was reviewed and tested to meet the UL 864 UUKL/UUKL7 acceptance criteria.

### Hardware

The hardware has been designed to meet UL 864 transient testing requirements on all communications and input/output points. This includes EIA-485 (formerly RS-485) ports, Ethernet ports, power, and all I/O points. The result of these modifications has been to protect the I/A Series BACnet products against high level transients and further reduce the susceptibility of the I/A Series BACnet controllers to static electricity and lightning. This does not mean that lightning protection is not required. In fact, lightning protection is still required whenever communication lines enter or leave a building.

### Software

A systems level application was created, documented, and tested to prove I/A Series BACnet controllers could perform a smoke-control sequence within the guidelines of UL 864 UUKL/UUKL7 and NFPA 92A. This systems level application used a representative selection of I/A Series BACnet hardware. Three additional systems applications were created to provide a guideline for applying I/A Series BACnet controllers to generic smoke-control situations. These applications are briefly explained here and detailed in Chapters 2 through 4.

- High-rise Smoke Control Using MNB-300, MNB-Vx, and MNB-1000 Controllers

Detailed in Chapter 2, this application provides guidelines for using I/A Series BACnet controllers in a five-floor, high-rise office building that requires the UL 864 UUKL/UUKL7 listing for Smoke-Control Systems. This application performs the smoke-control sequences by controlling stairwell pressurization

---

2. Underwriters Laboratories, *Heating, Cooling, Ventilating, Cooking and Food Safety Equipment Directory 2006*.

systems, terminal boxes, dedicated smoke-control dampers, and central air handling unit (AHU) systems. The normally open (N.O.) relay contacts of a UOJZ fire alarm panel are monitored for smoke/fire alarm signals which initiate automatic activation of the smoke-control sequences. The UUKL listed Firefighter's Smoke Control Station (FSCS) is monitored for manual activation and overrides. Control of the FSCS visual and audible status indicators is also provided.

- **Warehouse Smoke Control Using MNB-300 and MNB-1000 Controllers**

Detailed in Chapter 3, this application provides guidelines for using I/A Series BACnet controllers in a single-story warehouse building that requires the UL 864 UUKL/UUKL7 listing for Smoke-Control Systems. This application performs the smoke-control sequences by controlling several zoned AHU systems. The N.O. relay contacts of a UOJZ fire alarm panel are monitored for smoke/fire alarm signals which initiate automatic activation of the smoke-control sequences. The UUKL listed Firefighter's Smoke Control Station (FSCS) is monitored for manual activation and overrides. Control of the FSCS visual and audible status indicators is also provided.

- **Campus Smoke Control Using MNB-300, MNB-Vx, and MNB-1000 Controllers**

Detailed in Chapter 4, this application provides guidelines for using I/A Series BACnet controllers in a large campus with multiple buildings that require the UL 864 UUKL/UUKL7 listing for Smoke-Control Systems. This application performs the smoke-control sequences by controlling terminal boxes, dedicated smoke-control dampers, and several AHU systems. The N.O. relay contacts of a UOJZ fire alarm panel are monitored for smoke/fire alarm signals which initiate automatic activation of the smoke-control sequences. The UUKL listed Firefighter's Smoke Control Station (FSCS) is monitored for manual activation and overrides. Control of the FSCS visual and audible status indicators is also provided. Multiple Fire Alarm Panels and FSCSs are used.

## **What are Your UL 864 UUKL/UUKL7 Responsibilities?**

Schneider Electric field offices can now contract for smoke-control systems that require the UL 864 UUKL/UUKL7 listing for a BACnet system. The I/A Series BACnet system, however, is not the system that initiates or annunciates the smoke/fire alarm. That is the responsibility of the primary system, a dedicated fire alarm system that is listed for the UOJZ category of the UL 864 standard. The primary system provides the means for detecting, indicating, and annunciating the smoke/fire alarm. I/A Series BACnet controllers interface to the primary fire alarm system to monitor the smoke/fire alarm panel output contacts and subsequently control the HVAC equipment, as required, in the event of a fire/smoke condition. In addition, the automation system may redundantly (as a secondary system) annunciate fire/smoke alarms.

The applications produced and the guidelines provided by Schneider Electric in the *I/A Series MicroNet BACnet Smoke-Control Systems Manual* are intended as a reference. They must be reviewed and revised to fit the individual installation and the project's specifications. It is the individual field office's responsibility to ensure that the I/A Series BACnet system meets the requirements of the project's

specifications, but not necessarily to perform the system's mechanical design function. The smoke-control system designer should have already completed the mechanical system design, and validated the design's concept using a proven smoke-control system program model.

Proper duct sizing and layout, motor/blower selection, and damper selection must be completed by the smoke-control system designer to provide the planned smoke-control pressurization under all possible expected environmental (wind, weather, etc.) and building (door, elevator hoistway, leakage, system response, stairwell, occupied mode, etc.) conditions. Adjacent corridors and zones should have been considered by the smoke-control system designer because they have a direct impact on pressurization.

The smoke-control system designer should also specify the required controls sequence, and realizing that there are reaction and confirmation times for HVAC controls, specify any critical response times that are necessary to meet the requirements of the smoke-control system design.

Each field office is responsible for the implementation of the smoke-control sequence as specified by the smoke-control system designer. Additionally, it is the responsibility of the field office to work with the smoke-control system designer and gain the smoke-control system approval from the Authority Having Jurisdiction (AHJ) — and there could be several. I/A Series BACnet equipment installation must be in strict adherence to the appropriate UL, NFPA, and local authority requirements. The field office is responsible for following the installation standards and guidelines set forth by Schneider Electric in this document and as approved by UL.

## Explanation of Smoke-Control Systems

This documentation is intended to be used in conjunction with the NFPA 92A and UL 864 UUKL/UUKL7 standards. The explanation of smoke-control systems here consists of highlights from these standards.

### Building Pressurization

The primary means of controlling smoke movement is by creating air pressure differences between smoke-control zones. The basic concept of building pressurization is to establish a higher pressure in adjacent spaces than in the smoke zone. In this way, air moves into the smoke zone from the adjacent areas and smoke is prevented from dispersing throughout the building.<sup>3</sup>

### Dedicated and Nondedicated Systems

Smoke control systems are either dedicated or nondedicated. A dedicated smoke-control system is intended for smoke-control purposes only. It is a separate system of air moving and distribution equipment that does not function under normal building operating conditions. When activated, this type of system performs a specific smoke-control function.<sup>4</sup> Examples of dedicated smoke-control systems are stairwell pressurization fans and exhaust dampers that operate only when in a smoke-control situation.

---

3. National Fire Protection Association, Inc., NFPA 92A, *Standard for Smoke-Control Systems Utilizing Barriers and Pressure Differences*, 2009 ed., chap. 1, para. 1.2.1.

4. NFPA 92A, 2009 ed., chap 3, para. 3.3.11.1, 3.3.11.2..

Nondedicated smoke-control systems are systems that share components with some other systems such as the building automation (HVAC) system. When activated, the system changes its mode of operation to achieve the smoke-control objectives.<sup>5</sup> An example of this type of system is the central air handler for a building that supplies several smoke-control zones. Under normal HVAC operation, the central air handler modulates the outdoor, exhaust, and return air dampers to maintain a desired discharge temperature. When a smoke-control sequence is initiated, the control objective changes from maintaining a desired discharge temperature to a smoke-control sequence that drives the outdoor and exhaust air dampers fully open and the return air damper fully closed to provide the maximum amount of outdoor air.

## Basic System Types

Building smoke-control systems can generally be divided into two basic types: shaft protection and floor protection. Shaft protection consists of stairwell pressurization systems and elevator hoistway systems. Floor protection involves several variations of zoned smoke control. Use of a particular system or combination of systems is dependent on building and fire code requirements, as well as specific occupancy and life safety requirements of the situation being considered.

---

**Note:** Recent trends have indicated areas of refuge are being designed into many buildings as dictated by the Americans for Disabilities Act (ADA). Specifications may refer to these areas of refuge which are typically located adjacent to stairwells or elevator hoistways. These refuge zones may require special pressure compensated systems in order to maintain a tenable environment. The requirements for these systems must be dictated by the building's smoke-control system designer based on the smoke-control system design and its associated sequence of operation. When these types of zones are encountered, additional time and resources may be required to establish and verify compliance to the specification. These areas of refuge are not part of the UUKL listing requirements.

---

## Shaft Protection

### Stairwell Pressurization Systems

The goal of pressurized stairwells is to maintain “a tenable environment within exit stairwells for the time necessary to allow occupants to exit the building.”<sup>6</sup> A tenable environment is defined as “An environment in which the products of combustion, including toxic gases, particulates, and heat, are limited or otherwise restricted to maintain the impact on occupants to a level that is not life threatening.”<sup>7</sup> A secondary objective of stairwell pressurization is to provide a staging area for firefighters.<sup>8</sup> This is achieved when “stair shafts are mechanically pressurized, with respect to the fire area, with outdoor air to keep smoke from contaminating them during a fire incident.”<sup>9</sup>

---

5. NFPA 92A, 2009 ed., chap 3, para. 3.3.11.2.

6. NFPA 92A, 2009 ed., chap. 4, para. 4.1.2 (2), annex A, para. A.8.1.

7. NFPA 92A, 2009 ed., chap. 4, para 4.1.2 (2).

8. NFPA 92A, 2009 ed., annex A, para A.4.1.2 (1).

9. NFPA 92A, 2009 ed., chap 3, para 3.3.6..

There are two types of stairwell systems: noncompensated and compensated. In a noncompensated system, supply air is provided to the stairwell by starting a fan. This provides two or more positive pressure differentials: one differential with all of the doors closed, a second differential with one door open, and so on.<sup>10</sup> In a compensated system, supply air is also provided to the stairwell by starting a fan, but the fan system adjusts the positive differential pressure based on the various combinations of opened and closed doors. This adjustment may be accomplished by either modulating supply airflows or by relieving excess pressure from the stairwell.<sup>11</sup> Typically, over-pressure relief may utilize barometric dampers, motor-operated dampers, an automatically opening stairwell door to the outside at ground level, or an exhaust fan.<sup>12</sup>

### **Elevator Smoke Control**

“Historically, elevator hoistways have proved to be a readily available conduit for the movement of smoke throughout buildings.”<sup>13</sup> Although several methods for correcting this problem have been proposed and investigated, there are no firm recommendations regarding elevator smoke control. Refer to the NFPA 92A and UL 864 UUKL/UUKL7 standards for additional information. Remember, the local AHJ and project specifications may require control beyond that specified in the above standards.

### **Floor Protection**

#### **Zoned Smoke Control**

Pressurized stairwells, discussed above, “are intended to control smoke to the extent that they inhibit smoke infiltration into the stairwell. However, in a building with just a pressurized stairwell, smoke can flow through cracks in floors and partitions and through other shafts to threaten life or damage property at locations remote from the fire. The concept of zoned smoke control ...is intended to limit this type of smoke movement within a building.”<sup>14</sup>

With zoned smoke control, smoke movement is inhibited by dividing the building “into smoke-control zones, with each zone separated from the others by smoke barriers.”<sup>15</sup> These smoke barriers can be partitions, floors, or doors that can be closed. When a fire occurs in one of these smoke-control zones, it is called a smoke zone.<sup>16</sup> In the event of a fire, pressure differences and airflows produced by mechanical fans and operating dampers can be used to limit the smoke to the zone in which the fire originated.<sup>17</sup> When a fire/smoke condition occurs, all of the nonsmoke zones that are contiguous to the smoke zone are positively pressurized and the smoke zone is negatively pressurized. Optionally, all of the remaining smoke-control zones in the building may also be positively pressurized.<sup>18</sup> With the smoke contained to the smoke zone, it can then be

---

10.NFPA 92A, 2009 ed., annex B, para. B.1.

11.NFPA 92A, 2009 ed., annex B, para. B.2.

12.NFPA 92A, 2009 ed., annex B, para. B.4.

13.NFPA 92A, 2009 ed., annex A, para. A.5.4.

14.NFPA 92A, 2009 ed., annex A, para. A.5.5, annex A, para. A.8.1.

15.NFPA 92A, 2009 ed., chap. 5, para. 5.5.1.1.

16.NFPA 92A, 2009 ed., chap. 3 para. 3.3.15.

17.NFPA 92A, 2009 ed., annex A, para. A.5.5.

18.NFPA 92A, 2009 ed., annex A, para. A.5.5.1.1.1.

exhausted. Typically, the fire/smoke signals from a protective signaling system (UOJZ, a UL 864 Listed Fire Alarm Control Unit; i.e. fire alarm panel) are used to activate the zoned smoke-control sequence.<sup>19</sup>

## **HVAC Equipment**

HVAC equipment normally provides a means of supplying, returning and exhausting air to, or from, a space. Most HVAC equipment “can be adapted to provide the necessary logic and control sequences to configure HVAC systems for smoke control.”<sup>20</sup> However, when the supply and return air ducts are interconnected as part of the normal HVAC operation, smoke dampers are needed to separate the supply and exhaust air during a smoke-control sequence (return air damper).<sup>21</sup> Additionally, some buildings use centralized HVAC equipment in main mechanical areas to serve multiple floors or zones. These central systems may require fire and smoke shaft dampering to provide exhaust of the fire floor and pressurization of the adjacent floors with outdoor air. Due to their capacity, central systems should include a means to prohibit excessive pressures within the duct system and prevent rupture, collapse, or other damage.<sup>22</sup>

Typically, fan coil units and water source heat pump units can be excluded from performing smoke-control sequences. However, if these units have the ability to supply outdoor air, any of the units that are within the smoke zone should be shut down so that the zone can be negatively pressurized.<sup>23</sup> If an induction-type air handling unit is used within a smoke zone, it should be shut down or have its primary air supply closed off.<sup>24</sup>

Some VAV systems bypass supply air to the return air inlet of the fan. In these cases, the bypasses must be closed when the unit is in the smoke-control mode. Additionally, the VAV system fan and terminal unit controls should be configured to supply the maximum amount of outdoor air to pressurize the nonsmoke zones.<sup>25</sup> If a fan-powered terminal unit is supplying the smoke zone, the terminal fan should be turned off. “Terminal units serving zones adjacent to the smoke zone can continue to operate.”<sup>26</sup>

## **Smoke-Control System Activation**

“Operating controls of the HVAC system shall be designed or modified to provide the smoke-control mode with the highest priority over all other control modes.”<sup>27</sup> Normally the smoke-control sequences are activated automatically, but in some cases, manual activation may be more appropriate. In either case, “the smoke-control system shall be capable of being manually overridden and manually deactivated.”<sup>28</sup> The automatic smoke-control system “shall be automatically activated in response to signals received from a specific fire detection device or a combination of fire detection devices.”<sup>29</sup> Fire detection devices “include automatic devices such

---

19.NFPA 92A, 2009 ed., chap. 6, para. 6.4.5.1.1.

20.NFPA 92A, 2009 ed., annex A, para. A.6.4.2.

21.NFPA 92A, 2009 ed., chap. 6, para. 6.2.3.

22.NFPA 92A, 2009 ed., annex C, para. C.3.

23.NFPA 92A, 2009 ed., annex C, para. C.4.

24.NFPA 92A, 2009 ed., annex C, para. C.5.

25.NFPA 92A, 2009 ed., annex C, para. C.7.

26.NFPA 92A, 2009 ed., annex C, para. C.8.

27.NFPA 92A, 2009 ed., chap. 6, para. 6.4.2.

28.NFPA 92A, 2009 ed., chap. 6, para. 6.4.3.3.

29.NFPA 92A, 2009 ed., chap. 6, para. 6.4.3.4.

as smoke detectors, waterflow switches, and heat detectors.”<sup>30</sup> Manual fire alarm pull stations should generally not be used to activate automatic smoke-control systems, other than stairwell pressurization systems, because of the likelihood of a person signaling an alarm from a station outside the smoke zone of origin.<sup>31</sup>

## Response Time

Smoke control system activation should be started immediately after receiving an activation command. A maximum of 10 seconds transmission time is allowed, from the initiation of an activation signal (i.e. fire alarm input), to the time it reaches the MicroNet BACnet smoke control system (i.e. binary input of a MicroNet controller). The smoke-control sequence should activate individual components in the sequence necessary to prevent physical damage to fans, ducts, dampers, and other equipment. The total response time of the individual component starts from the moment the smoke-control command is issued (whether automatic or manual) to the final action. This time is 60 seconds for fan operation at the desired state and 75 seconds for the completion of the damper travel.<sup>32</sup> Should an individual component fail, the time lapse from the moment the component should have reached its final state and the moment its associated trouble signal annunciates, should not exceed 10 seconds.<sup>33</sup> This means that the annunciation of the trouble signal for a fan must occur within 70 seconds of the automatic or manual activation command. The annunciation of the damper trouble signal must occur within 85 seconds of the automatic or manual activation command.

## Firefighter’s Smoke Control Station

The Firefighter’s Smoke Control Station (FSCS) “shall provide status indication, fault condition indication, and manual control of all smoke-control system components.”<sup>34</sup> “The FSCS shall have the highest priority control over all smoke-control systems and equipment.”<sup>35</sup> “FSCS control shall not take precedence over fire suppression, electrical protection, or personnel protection devices.”<sup>36</sup> For more information, refer to the NFPA 92A and UL 864 UUKL/UUKL7 standards.

The FSCS should contain a building diagram that clearly indicates the type and location of all smoke control equipment, such as fans and dampers.<sup>37</sup> The areas of the building that are affected by the equipment and the actual status of all of the smoke control equipment should be clearly indicated at the FSCS. Status indication should be provided for each fan showing whether it is ON or OFF. Status indication of the full-closed and full-open positions of each smoke control damper should also be shown on the FSCS.<sup>38</sup> Proof of air flow should be used to determine the fan status. Proof

---

30.NFPA 92A, 2009 ed., annex 6, para. A.6.4.3.4.

31.NFPA 92A, 2009 ed., chap. 6, para’s 6.4.3.5.2 and 6.4.3.5.3, and annex A, para’s A.6.4.3.5.2 and A.6.4.3.5.3.

32.Underwriters Laboratories Inc., UL 864, *Control Units and Accessories for Fire Alarm Systems*, 9th ed. (2003), para. 49.2.c.

33.UL 864, 9th ed., para. 49.2.b

34.NFPA 92A, 2009 ed., chap. 6, para. 6.4.3.7.3.

35.NFPA 92A, 2009 ed., chap. 6, para. 6.4.3.7.11.

36.NFPA 92A, 2009 ed., chap. 6, para. 6.4.3.7.14, and UL 864, 9th ed., para. 48.3.

37.NFPA 92A, 2009 ed., chap. 6, para 6.4.3.7.10 and annex D, para D.1 (2).



of damper positions should be done using end process verification. This may be done through the use of damper degree-of-opening switches, flow stations, etc.

Whenever the communications fails between any of the I/A Series MicroNet BACnet controllers that are integral to the smoke-control equipment or sequences, including instances when a controller loses power, a system trouble visual indicator (i.e. LED) at the FSCS should illuminate and an audible signal must sound.<sup>39</sup> The visual and audible trouble indicators must also be generated if any of the smoke-control equipment proof sensors fail to operate within a specified period of time during the smoke-control sequence or when under control of the FSCS.<sup>40</sup> In general, all visual trouble indicators must annunciate an audible sound. In addition to the status indication that is required for all of the smoke-control equipment, each dedicated piece of smoke-control equipment must also provide a visual trouble indicator specifically for that device.<sup>41</sup>

## **Control Sequence for Stair Pressurization Systems**

Any time a smoke/fire detector trips (refer to NFPA 92A and UL 864 UUKL/UUKL7 for acceptable signaling device types), initiating an automatic smoke-control sequence, all stairwell pressurization fans shall be energized<sup>42</sup>, with one exception. “Where an engineering analysis determines that operation of all stairwell pressurization fans is not required to achieve the design objective, only the stairwell pressurization fans identified during the analysis shall be required to be activated.”<sup>43</sup> A smoke detector should be provided in the air supply to each fan that stops the respective pressurization fan when smoke is detected.<sup>44</sup> A manual override switch for each fan should be provided at the FSCS that allows the stairwell fans to restart after they have been shutdown due to the supply air smoke detectors,<sup>45</sup> should it be determined that a lesser hazard exists from smoke entering the fan than smoke migrating into the stairwell. When a stairwell pressurization sequence is used in conjunction with zoned smoke control, care must be taken to prevent the interrelation of the two sequences from adversely affecting each other.<sup>46</sup>

## **Control Sequence for Zoned Smoke-Control Systems**

“Automatic activation of systems and equipment for zoned smoke control should have the highest priority over all other sources of automatic control within the building.”<sup>47</sup> For example, when the smoke-control equipment is used for normal building control such as HVAC systems, the equipment control should be pre-empted as required by the smoke-control sequence. “The following controls should not be automatically overridden:

- Static pressure high limits.

38.NFPA 92A, 2009 ed., chap 6, para's 6.4.3.7.3 through 6.4.3.7.10, and annex D, para D.1 (5).

39.UL 864, 9th ed., para's 48.5, 49.4, 49.6, and 49.7.

40.UL 864, 9th ed., para's 48.5 and 49.6.

41.NFPA 92A, 2009 ed., chap 6, para's 6.4.3.7.3 and UL 864, 9th ed., para 49.6.

42.NFPA 92A, 2009 ed., chap 6, para 6.4.4.1.

43.NFPA 92A, 2009 ed., chap 6, para 6.4.4.1.1.

44.NFPA 92A, 2009 ed., chap 6, para's 6.4.4.2.1 and 6.4.4.2.2.

45.NFPA 92A, 2009 ed., chap 6, para 6.4.4.4.

46.NFPA 92A, 2009 ed., annex A, para. A.5.7.

47.NFPA 92A, 2009 ed., chap. 6, para. 6.4.5.2.1.

- Duct smoke detectors on supply air systems.”<sup>48</sup>

Manual activation or deactivation of zoned smoke-control systems and equipment (at the FSCS) should take priority over automatic activation, as well as take priority over all other sources of automatic control within the building.<sup>49</sup> Manual controls provided specifically for this purpose should be clearly marked as to the zone and function served (typically part of the FSCS).<sup>50</sup>

Any time a smoke/fire detector trips initiating an automatic smoke-control sequence, all stairwell pressurization sequences should operate as stated previously.<sup>51</sup> For applications where each central air handling unit (AHU) supplies several smoke-control zones, the supply and return fan for the AHUs are commanded ON. The outdoor and exhaust air dampers for each AHU drive to the full-open position and the return air damper drives to the full-closed position. All exhaust air dampers in the smoke zone drive to the full-open position and the supply air dampers drive to the full-closed position. All smoke-control zones contiguous to the smoke zone (and optionally all remaining smoke-control zones<sup>52</sup>) should have their supply air dampers driven to the full-open position and their exhaust air dampers driven to the full-closed position. Pressurization of the non-contiguous (optional) smoke-control zones is dependent upon the smoke-control system design and its associated specification. Regardless of whether or not non contiguous zones are positively pressurized, sufficient differential pressure must be achieved to limit the smoke spread to the zone in which the fire originated.

This smoke-control sequence provides the maximum amount of outdoor air to the nonsmoke zones causing them to be positively pressurized. Since the exhaust air dampers are fully open in the smoke zone and no supply air is being provided, the AHU begins exhausting the smoke from the smoke zone. With the nonsmoke zones being positively pressurized in this manner, smoke is inhibited from migrating outside of the smoke zone.

## **Automatic Response To Multiple Signals**

Once an automatic activation has occurred, subsequent alarm signals that would normally result in the automatic actuation of a smoke-control sequence should be annunciated only. No fans or dampers should be actuated in response to any subsequent automatic alarm signal in order to avoid the possibility of defeating any smoke-control sequence which is in process.

## **Maintaining System Integrity**

A prime concern with any emergency signaling system is maintaining system integrity. This is typically accomplished by electrical supervision of wiring, however, since the proper operation of the fans and dampers associated with a smoke-control system may involve mechanically and pneumatically operated devices, as well as electrically operated devices, end-process verification is considered an acceptable alternative.

Smoke control system equipment is required to verify that a fan or damper has achieved its required end function. This end function verification consists of monitoring fans by differential pressure switches, flow stations, and etc., and

---

48.NFPA 92A, 2009 ed., chap. 6, para. 6.4.5.2.1.2.

49.NFPA 92A, 2009 ed., chap. 6, para. 6.4.5.2.2.

50.NFPA 92A, 2009 ed., chap. 6, para. 6.4.5.2.4.1.

51.NFPA 92A, 2009 ed., chap 6, para's 6.4.4.1 and 6.4.4.1.1.

52.NFPA 92A, 2009 ed., annex A, para. A.5.5.1.1.1.

monitoring dampers by degree-of-opening switches, differential pressure switches, and etc. These verification devices should be connected back to the smoke-control system equipment (I/A Series BACnet, for example) and the system programmed to expect the appropriate signal within the specified amount of time.<sup>53</sup>

Any change in a smoke-control signal input (i.e. FAP, FSCS, etc) must be received into the smoke-control system in 10 seconds or less. Fans and dampers have 60 and 75 seconds, respectively, from the time the signal input is received, to successfully respond to smoke-control sequence commands. If a fan or damper fails to achieve its desired state within the times referenced above, the failures have to be annunciated within an additional 10 seconds. Other trouble signals, such as communication failures (supervised through software), have up to 200 seconds to annunciate their failures.<sup>54</sup>

Annunciation of the end function sensor is not required if the proof sensor operates as intended, but if the proof sensor fails to operate, an audible and visual trouble signal must be generated at the FSCS. This would be typical of the operation of the smoke-control system during an emergency condition.

For operation during a nonemergency condition, the means for verifying system integrity varies based on whether the smoke-control system is a dedicated or nondedicated system. Nondedicated smoke-control systems and equipment consist of HVAC components within a building which are operated regularly. Therefore, the normal “comfort” level associated with the operability or inoperability of the equipment is considered an acceptable means of maintaining system integrity.<sup>55</sup>

Dedicated smoke-control systems and equipment are used solely for the purpose of smoke-control and are not operated in a nonemergency condition. Dedicated system equipment is therefore required to incorporate an automatic weekly self-test of each smoke-control function. The self-test consists of the smoke-control system automatically commanding the associated function to operate and expecting that the associated proof sensor operates within a specified period of time (refer to response times noted earlier). A valid proof sensor operation is not required to annunciate, however, the lack of an expected proof sensor operation must produce an audible trouble signal, as well as indicate the specific device that did not operate (for example, LED at the FSCS).

## **Smoke-Control System Schedule**

Each different smoke-control system configuration/sequence should be defined in a schedule, typically a matrix chart. The schedule should list all dedicated and nondedicated smoke-control equipment and show the equipment response for each sensor that activates an automatic sequence. At a minimum, the schedule should include the following information:

- Each smoke zone in which a smoke-control system automatically activates.

---

53.NFPA 92A, 2009 ed., chap. 6, para. 6.4.6. and annex A, para. A.6.4.6.

54.UL 864, 9th ed., para. 36.1.2 (c), 49.2 (b).

55.NFPA 92A, 2009 ed., chap. 2, para. 2.1.2. and 2.1.5., and UL 864, 9th ed., para's 49.7.

- The type of alarm signal that activates the smoke-control system (smoke detector, sprinkler water flow, and etc.)
- The smoke zones where maximum mechanical exhaust to the outside is implemented and no supply air is provided.
- The positively pressurized smoke-control zones where maximum supply air is implemented and no exhaust to the outside is provided.
- The fans that are ON as required to implement the smoke-control system. Multiple-speed fans should be further noted as FAST or MAX VOLUME to ensure that the intended control configuration is achieved.
- The fans that are OFF as required to implement the smoke-control system.
- The dampers that are Open where maximum air flow must be achieved.
- The dampers that are Closed where no air flow should take place.
- Any additional functions that may be required to achieve the smoke-control objective or that may be desirable in addition to smoke control. Changes or override of normal static pressure control setpoints should also be indicated if applicable.
- Damper position at fan failure.<sup>56</sup>

## Conclusion

When applying I/A Series BACnet controllers to smoke-control sequences, review this introductory information along with the NFPA 92A and UL 864 UUKL/UUKL7 standards. This information should be used in conjunction with the sample smoke-control applications (Chapters 2 through 4) and the restrictions and general comments (Chapter 5) that are part of the total smoke-control documentation provided by Schneider Electric.

---

<sup>56</sup>.NFPA 92A, 2009 ed., annex A, para 6.4.5.3 (10).

---

## **Chapter 2**

# **High-rise Smoke Control**

### **Purpose**

This application provides guidelines for using I/A Series MicroNet BACnet controllers in a five-floor, high-rise office building (Figure–2.1) that requires the UL 864 UUKL/UUKL7 listing for Smoke-Control Systems. This application uses MNB-300, MNB-Vx, and MNB-1000 controllers that perform HVAC functions when in the normal control mode. When in the smoke-control mode, they perform the required smoke-control sequences by controlling the stairwell pressurization fans, the individual terminal boxes, the dedicated smoke-control dampers, and the central air handling unit (AHU) fans. Additionally, they control all supply, exhaust, and return air dampers, and provide the feedback of all end-process verification required.

The I/A Series BACnet controllers monitor N.O. relay contacts of a UOJZ listed fire alarm panel for automatic activation of the smoke-control sequences and monitor a UL 864 UUKL/UUKL7 Listed Firefighter’s Smoke Control Station (FSCS) for manual activation commands and overrides. In this example, an ADI FSCS is used, which supports the ADI ModBus interface to the MNB-1000. This interface provides control over all the FSCS visual and audible status indicators, as well as receipt of the FSCS override commands, thus eliminating the need to allocate additional controllers to interface to the FSCS through individual I/O points.

### **Sequence of Operation**

#### **Normal HVAC Control**

Under normal conditions, the central AHU follows an occupied schedule that determines when the AHU operates. During the unoccupied mode, the outdoor and exhaust air dampers are in the full-closed position. The return air damper is in the full-open position. The supply and return fans are commanded OFF. During the occupied mode, the supply and return fans are commanded ON. The outdoor, exhaust, and return air dampers modulate as required to maintain a mixed air temperature setpoint. The central AHU can have a wide variety of additional control sequences that determine its operation and establish its operating priorities (for example, low limit stats and minimum outdoor air).

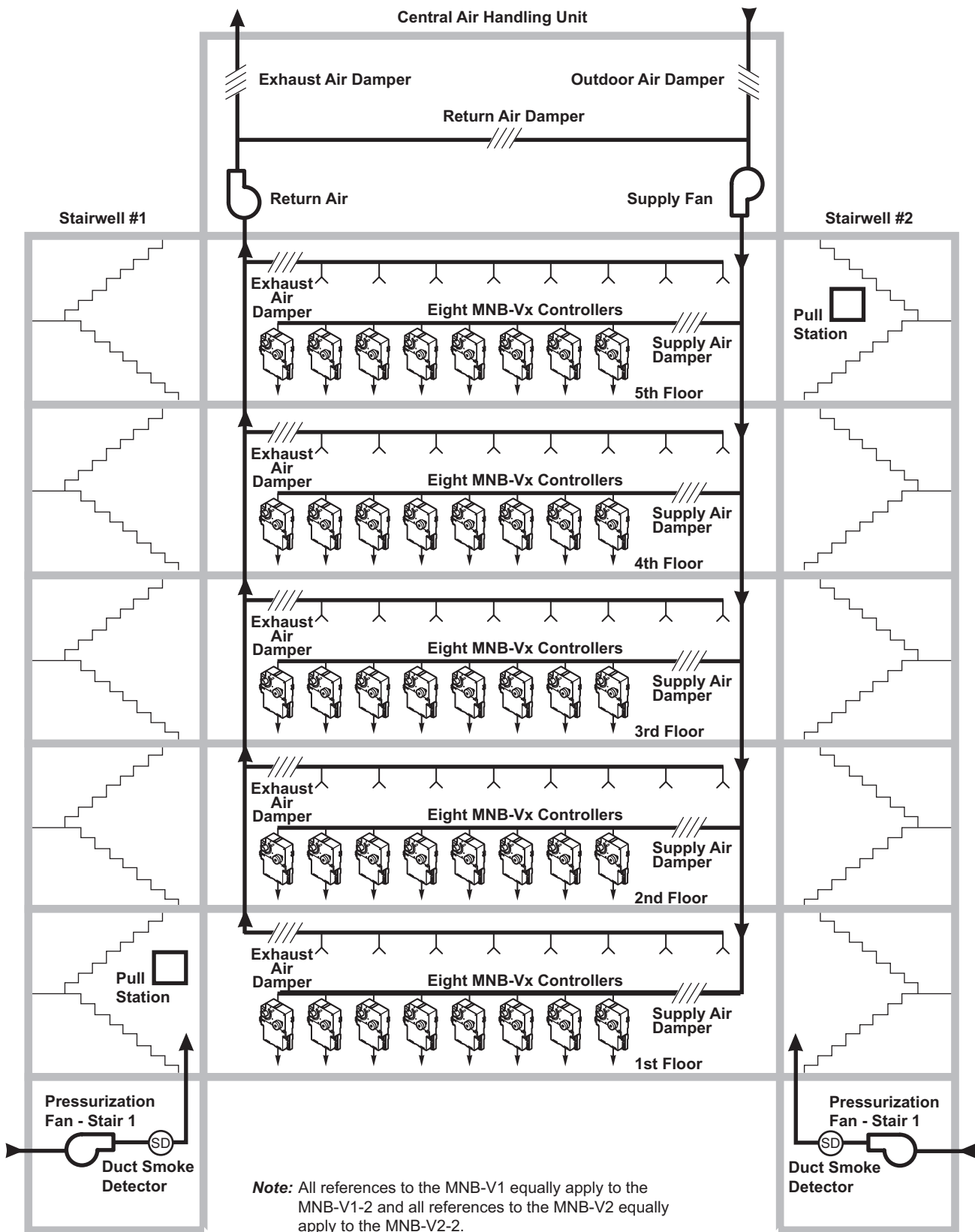

Figure-2.1 High-rise Building Layout.

The terminal boxes are controlled by MNB-V1 and MNB-V2 controllers. During normal conditions and in the occupied mode, the terminal boxes maintain their respective zone temperature setpoints by modulating their primary air dampers and staging the electric reheat coils (if present). During the unoccupied mode, the terminal boxes either maintain their respective unoccupied zone temperature setpoints or drive to a fixed position.

In many cases, a dedicated motor-driven damper is required in the common supply air duct that feeds each smoke-control zone. The dampers are required to ensure that the smoke zones can be negatively pressurized (with respect to all contiguous smoke-control zones) within the 75 second response time required by NFPA 92A and UL 864 UUKL/UUKL7. Dedicated supply air dampers and their control are shown in this example to cover worst case MNB-V1 and MNB-V2 applications. The dedicated supply air dampers are controlled by digital output (DO) points from the MNB-Vx controllers associated with their respective zones. The dampers remain in the full-open position at all times, unless commanded otherwise due to a smoke-control related condition.

---

**Note:** The UL acceptance of the MNB-V1 and MNB-V2 controllers for UUKL/UUKL7 is based on the assumption that negative pressurization of a smoke zone is considered accomplished when the total CFM flow supplied to the zone drops below 50% of its maximum with its dedicated exhaust damper fully open. If the damper response time is acceptable (less than 75 seconds) under this condition and proper pressurization is achieved, dedicated supply air dampers are not necessary solely to meet response time requirements. In all cases, exhaust and supply air dampers should continue to be driven to their full-open and full-closed positions. The smoke-control system design and its associated specification will dictate whether additional requirements apply to the supply air dampers.

---

The exhaust air dampers associated with each floor (smoke-control zone) are considered dedicated smoke-control systems, and in this application, are controlled by digital output (DO) points from the MNB-Vx controllers associated with their respective zones. The dampers are always in the full-open position, unless commanded otherwise due to a smoke-control related condition. Typically, these dampers use actuators that spring-return to their “fail-safe” position upon power loss.

The dedicated stairwell pressurization fans are controlled by an MNB-300 controller. The status of each fan is monitored by a flow switch. Since these fans are considered dedicated smoke-control equipment, they are always OFF, unless commanded otherwise due to a smoke-control related condition.

The Fire Alarm Panel (i.e. Listed Fire Alarm Control Unit) is the primary indicator for fire alarm, smoke detector, and pull station conditions. It is also the primary initiator of the automatic smoke/fire alarm sequence. Upon detection of smoke and/or fire, a set of contacts in the Fire Alarm Panel (for the zone affected) close, indicating to the building automation system that a smoke or fire condition exists. In this application, a smoke detector is provided for each floor (smoke-control zone). Smoke detectors are also provided in the supply air for each stairwell

pressurization fan. The contacts from the Fire Alarm Panel for the associated smoke detectors and stairwell pull stations are monitored by MNB-300 controllers.

---

**Note:** Any UOJZ listed fire alarm panel with programmable N.O. relay contacts can be used with I/A Series BACnet controllers.

---

The Automation Displays, Inc. Firefighter's Smoke Control Station (i.e. Listed Smoke Control Panel) is the primary indicator for the status of all smoke control and related HVAC equipment. It also provides the interface for the manual activation commands and overrides for all smoke-control related equipment. An MNB-1000 controller is mounted internal to the FSCS and provides the ADI ModBus (control) interface to the FSCS. All commands issued from the FSCS are monitored and distributed throughout the network as required to implement the manual smoke-control sequences and overrides. The status of all of the smoke-control systems and equipment, as well as HVAC monitored trouble signals, are returned to the FSCS for visual indication and in some cases audible annunciation. The FSCS MNB-1000 will be the central coordinator of all smoke-control activity.

---

**Note:** Currently, only the UUKL Listed FSCS from Automation Displays, Inc. (ADI) supports the ADI ModBus interface. For those applications where the ADI ModBus serial communication interface is used, only the ADI FSCS can be used. Whenever discrete I/O points are used to communicate with the FSCS, any UUKL Listed FSCS can be used. When discrete I/O is used for this purpose, many additional I/A Series controllers will be required to provide the individual I/O point interfaces, and this should be considered when estimating a job.

---

During normal operating conditions, the nondedicated smoke-control equipment does not require an automatic self-test since this equipment consists of HVAC components that are operated on a regular basis. The normal "comfort" level associated with the operability or inoperability of the equipment is considered an acceptable means of maintaining system integrity.

Dedicated smoke-control equipment, however, is used only when a smoke-control situation occurs, and therefore an automatic weekly self-test of each dedicated smoke-control function is required. In this application, stairwell pressurization fan operation is verified using differential pressure sensors. The MNB-Vx damper position is verified by monitoring the cubic feet per minute (CFM) flow from the terminal box and/or its integral damper position feedback. Damper end switches are used to verify the end stroke of all other motor-driven dampers. If a valid proof of each function occurs, no annunciation needs to take place. Otherwise, if the expected proof sensor does not operate as required, an audible trouble signal is generated and an LED is illuminated at the FSCS indicating the specific device that did not operate.



## Smoke Control Sequences

This application uses a combination of smoke-control systems to implement the smoke-control strategy. These systems consist of stairwell pressurization and zoned smoke control.

Anytime a fire alarm pull station is activated, the automatic stairwell pressurization sequence will be initiated. Since multiple pull stations will be present, activation of any station will initiate the sequence for both stairwells. When the automatic sequence is triggered in this manner, it will leave the remainder of the smoke-control system in its normal mode.

Anytime a smoke/fire detector trips, an automatic smoke-control sequence is initiated and both dedicated stairwell pressurization fans are energized. A smoke detector, provided in the air supply to each fan, stops the respective pressurization fan if smoke is detected.<sup>57</sup> A manual override switch (for each fan) provided at the FSCS allows the stairwell pressurization fans to be restarted after they have shutdown due to the air supply smoke detectors,<sup>58</sup> should it be determined that a lesser hazard exists from smoke entering the fan than from smoke migrating into the stairwell. The pressurization of the stairwell restricts the flow of smoke into the stairwell allowing ready evacuation of the smoke zone and providing a staging area for firefighters.<sup>59</sup>

Zoned smoke control divides a building into a number of zones for the purpose of inhibiting smoke movement.<sup>60</sup> The zones are separated from each other by smoke barriers. In the event of a fire, pressure differences and airflows produced by mechanical fans and operating dampers are used to limit the smoke to the zone in which the fire originated.<sup>61</sup> In this application, each floor of the high-rise is considered a smoke-control zone. When smoke is detected in any zone, all of the nonsmoke zones that are contiguous to the smoke zone, and optionally, all nonsmoke zones in the building,<sup>62</sup> are positively pressurized and the smoke is exhausted from the smoke zone. Pressurization of the noncontiguous (optional) smoke-control zones is dependent upon the smoke-control system design and its associated specification. Regardless of whether or not the noncontiguous smoke-control zones are positively pressurized, sufficient differential pressure must be achieved to limit smoke spread to the zone in which the fire originated.

If the smoke/fire detector for Floor 2 trips first, the automatic smoke-control sequence is initiated in the following manner.

1. The central AHU supply and return fans are commanded ON, the return air damper is driven to the full-closed position and the outdoor air and exhaust air dampers are driven to their full-open positions. This allows maximum fresh air to be delivered to the floors above and below the floor reporting the smoke condition. It also allows maximum exhausted air to be expelled from the zone reporting the smoke condition.
2. The dedicated exhaust air dampers for Floors 1, 3, 4, and 5 are driven to the full-closed position while the dedicated exhaust air damper for Floor 2 is driven to the full-open position.

---

57.National Fire Protection Association, Inc., NFPA 92A, *Standard for Smoke-Control Systems Utilizing Barriers and Pressure Differences*, NFPA 92A, 2009 ed., chap 6, para. 6.4.4.2.

58.NFPA 92A, 2009 ed., chap 6, para 6.4.4.4.

59.NFPA 92A, 2009 ed., chap. 4, para 4.1.2 (2) and annex A, para. A.4.1.2 (1).

60.NFPA 92A, 2009 ed., chap. 5, para. 5.5.1.1.

61.NFPA 92A, 2009 ed., annex A, para. A.5.5.

62.NFPA 92A, 2009 ed., annex A, para. A.5.5.1.1.1.

3. The dedicated supply air damper for Floor 2 is driven to the full-closed position. The terminal box supply dampers may optionally be driven to the full-closed position also. This causes the smoke zone to become negatively pressurized.

---

**Note:** The UL acceptance of the MNB-V1 and MNB-V2 controllers for UUKL is based on the assumption that negative pressurization of a smoke zone is considered accomplished when the total CFM flow supplied to the zone drops below 50% of its maximum with its dedicated exhaust damper fully open. Sufficient differential pressure must be achieved to ensure smoke spread is confined to the zone in which the fire originated. In all cases, exhaust and supply air dampers should continue to be driven to their full-open and full-closed positions.

---

4. The dedicated supply air dampers for Floors 1, 3, 4, and 5 remain in the full-open position. The respective terminal box supply dampers, which are controlled by MNB-V1 and MNB-V2 controllers, modulate open. The CFM flow supplied to these floors causes them to be positively pressurized. The terminal box supply dampers continue to modulate open until they reach the full-open position.

---

**Note:** The UL acceptance of the MNB-V1 and MNB-V2 controllers for UUKL is based on the assumption that negative pressurization of a smoke zone is considered accomplished when the total CFM flow supplied to the zone drops below 50% of its maximum with its dedicated exhaust damper fully open. In all cases, exhaust and supply air dampers should be driven to their full-open and full-closed positions. Sufficient differential pressure must be achieved to ensure smoke spread is confined to the zone in which the fire originated. In all cases, exhaust and supply air dampers should continue to be driven to their full-open and full-closed positions.

---

5. The automatic smoke-control sequence takes priority over the normal HVAC control sequences and any HVAC control overrides. Static pressure high limits and duct smoke detectors on supply air systems should not be automatically overridden.<sup>63</sup>
6. Once the automatic activation occurs, subsequent alarm signals that would normally initiate an automatic smoke-control sequence annunciate only. (For example if, in addition to the Floor 2 smoke/fire detector, the Floor 4 detector also trips, no change to the smoke-control sequence occurs and the Floor 4 smoke condition also annunciates at the FSCS.)
7. At any time, the FSCS is capable of overriding either partially, or in full, any automatic activation of a smoke-control sequence that may be in process.<sup>64</sup>
8. The communications between all of the I/A Series BACnet controllers that are part of the smoke-control sequences must be monitored. If the communications between any of these controllers fails, at any time, the system trouble LED at the FSCS must illuminate and an audible signal must be generated.<sup>65</sup>

---

63.NFPA 92A, 2009 ed., chap. 6, para's 6.4.2 and 6.4.5.2.1.2.

64.NFPA 92A, 2009 ed., chap. 6, para 6.4.3.7.11.

9. If any of the smoke-control equipment proof sensors fail to operate within a specified period of time during the smoke-control sequence, or when under control of the FSCS, the system trouble LED at the FSCS illuminates and an audible signal is generated. If the failed smoke-control equipment is dedicated, its associated trouble LED also illuminates.

If the smoke/fire detector for Floor 3 trips first, the automatic smoke-control sequence is initiated in the following manner.

1. The central AHU supply and return fans are commanded ON, the return air damper is driven to the full-closed position and the outdoor air and exhaust air dampers are driven to their full-open positions. This allows maximum outdoor air to be delivered to the floors above and below the floor reporting the smoke condition. It also allows maximum exhausted air to be expelled from the zone reporting the smoke condition.
2. The dedicated exhaust air dampers for Floors 1, 2, 4, and 5 are driven to the full-closed position while the dedicated exhaust air damper for Floor 3 is driven to the full-open position.
3. The dedicated supply air damper for Floor 3 is driven to the full-closed position. The terminal box supply dampers may optionally be driven to the full-closed position also. This causes the smoke zone to become negatively pressurized.

---

**Note:** The UL acceptance of the MNB-V1 and MNB-V2 controllers for UUKL is based on the assumption that negative pressurization of a smoke zone is considered accomplished when the total CFM flow supplied to the zone drops below 50% of its maximum with its dedicated exhaust damper fully open. Sufficient differential pressure must be achieved to ensure smoke spread is confined to the zone in which the fire originated. In all cases, exhaust and supply air dampers should continue to be driven to their full-open and full-closed positions.

---

4. The dedicated supply air dampers for Floors 1, 2, 4, and 5 remain in the full-open position. The respective terminal box supply dampers, which are controlled by MNB-V1 and MNB-V2 controllers, modulate open. The CFM flow supplied to these floors causes them to be positively pressurized. The terminal box supply dampers will continue to modulate open until they reach the full-open position.

---

**Note:** The UL acceptance of the MNB-V1 and MNB-V2 controllers for UUKL is based on the assumption that negative pressurization of a smoke zone is considered accomplished when the total CFM flow supplied to the zone drops below 50% of its maximum with its dedicated exhaust damper fully open. Sufficient differential pressure must be achieved to ensure smoke spread is confined to the zone in which the fire originated. In all cases, exhaust and supply air dampers should continue to be driven to their full-open and full-closed positions.

---

---

65. Underwriters Laboratories Inc., UL 864, *Control Units and Accessories for Fire Alarm Systems*, 9th ed. (2003), para's 48.5, 49.4, 49.6, and 49.7.

5. The automatic smoke-control sequence takes priority over the normal HVAC control sequences and any HVAC control overrides. Static pressure high limits and duct smoke detectors on supply air systems should not be automatically overridden.<sup>66</sup>
6. Once the automatic activation occurs, subsequent alarm signals that would normally initiate an automatic smoke-control sequence annunciate only. (For example if, in addition to the Floor 3 smoke/fire detector, the Floor 2 detector also trips, no change to the smoke-control sequence occurs and the Floor 2 smoke condition also annunciates at the FSCS.)
7. At any time, the FSCS is capable of overriding either partially, or in full, any automatic activation of a smoke-control sequence that may be in process.<sup>67</sup>
8. The communications between all of the I/A Series BACnet controllers that are part of the smoke-control sequences must be monitored. If the communications between any of these controllers fails, at any time, the system trouble LED at the FSCS must illuminate and an audible signal must be generated.<sup>68</sup>
9. If any of the smoke-control equipment proof sensors fail to operate within a specified period of time during the smoke-control sequence, or when under control of the FSCS, the system trouble LED at the FSCS illuminates and an audible signal is generated. If the failed smoke-control equipment is dedicated, its associated trouble LED also illuminates.

## Smoke-Control System Configuration Schedule

Each smoke-control system configuration should be defined in a schedule.<sup>69</sup> The schedule should list all dedicated and nondedicated smoke-control equipment and show the equipment response for each sensor that activates an automatic smoke-control sequence. An example schedule for this application is shown in [Table–2.1](#).

---

**Note:**

- According to NFPA 92A, only the smoke zones that are contiguous to the zone reporting the smoke condition have to be positively pressurized. For this application, all non-smoke zones are being positively pressurized.
  - Pressurization of the noncontiguous (optional) smoke-control zones is dependent upon the smoke-control system design and its associated specification. Regardless of whether or not noncontiguous smoke-control zones are positively pressurized, sufficient differential pressure must be achieved to ensure smoke spread is confined to the zone in which the fire originated.
- 

---

66.NFPA 92A, 2009 ed., chap. 6, para's 6.4.2 and 6.4.5.2.1.2.

67.NFPA 92A, 2009 ed., chap. 6, para 6.4.3.7.11.

68.UL 864, 9th ed., para's 48.5, 49.4, 49.6, and 49.7.

69.NFPA 92A, 2009 ed., chap. 6, para 6.4.5.3 and annex A, para A.6.4.5.3.

**Table–2.1 Schedule for Smoke-Control System Configuration.**

<b>Dedicated and Nondedicated Smoke Control Equipment</b>	<b>1st Floor Smoke Detector in Alarm</b>	<b>2nd Floor Smoke Detector in Alarm</b>	<b>3rd Floor Smoke Detector in Alarm</b>	<b>4th Floor Smoke Detector in Alarm</b>	<b>5th Floor Smoke Detector in Alarm</b>
AHU Supply Fan	ON	ON	ON	ON	ON
AHU Return Fan	ON	ON	ON	ON	ON
AHU O.A. Damper	Full Open	Full Open	Full Open	Full Open	Full Open
AHU Return Damper	Full Closed	Full Closed	Full Closed	Full Closed	Full Closed
AHU Exhaust Damper	Full Open	Full Open	Full Open	Full Open	Full Open
Stair 1 - Press. Fan	ON	ON	ON	ON	ON
Stair 2 - Press. Fan	ON	ON	ON	ON	ON
1st Floor Exhaust Damper	Full Open	Full Closed	Full Closed	Full Closed	Full Closed
1st Floor Supply Damper	Full Closed	Full Open	Full Open	Full Open	Full Open
1st Floor MNB-Vx Units 1 to 8	Full Closed	Full Open	Full Open	Full Open	Full Open
1st Floor as a Zone	Neg. Press.	Pos. Press.	Pos. Press.	Pos. Press.	Pos. Press.
2nd Floor Exhaust Damper	Full Closed	Full Open	Full Closed	Full Closed	Full Closed
2nd Floor Supply Damper	Full Open	Full Closed	Full Open	Full Open	Full Open
2nd Floor MNB-Vx Units 9 to 16	Full Open	Full Closed	Full Open	Full Open	Full Open
2nd Floor as a Zone	Pos. Press.	Neg. Press.	Pos. Press.	Pos. Press.	Pos. Press.
3rd Floor Exhaust Damper	Full Closed	Full Closed	Full Open	Full Closed	Full Closed
3rd Floor Supply Damper	Full Open	Full Open	Full Closed	Full Open	Full Open
3rd Floor MNB-Vx Units 17 to 24	Full Open	Full Open	Full Closed	Full Open	Full Open
3rd Floor as a Zone	Pos. Press.	Pos. Press.	Neg. Press.	Pos. Press.	Pos. Press.
4th Floor Exhaust Damper	Full Closed	Full Closed	Full Closed	Full Open	Full Closed
4th Floor Supply Damper	Full Open	Full Open	Full Open	Full Closed	Full Open
4th Floor MNB-Vx Units 25 to 32	Full Open	Full Open	Full Open	Full Closed	Full Open
4th Floor as a Zone	Pos. Press.	Pos. Press.	Pos. Press.	Neg. Press.	Pos. Press.
5th Floor Exhaust Damper	Full Closed	Full Closed	Full Closed	Full Closed	Full Open
5th Floor Supply Damper	Full Open	Full Open	Full Open	Full Open	Full Closed
5th Floor MNB-Vx Units 33 to 40	Full Open	Full Open	Full Open	Full Open	Full Closed
5th Floor as a Zone	Pos. Press.	Pos. Press.	Pos. Press.	Pos. Press.	Neg. Press.

## Firefighter's Smoke Control Station (FSCS)

The requirements of the FSCS are described below. For more information regarding the FSCS requirements, refer to the NFPA 92A standard.

### Location and Access

The FSCS should be located in proximity to other firefighter's systems that are provided within the building. Means should be provided to ensure only authorized access to the FSCS.

### Physical Arrangement

The FSCS should be designed to depict graphically the physical building arrangement, smoke-control systems and equipment, and the areas served by the equipment (Figure–2.2).<sup>70</sup>

### Status Indicators

Visual status indicators should be provided for all smoke-control equipment.<sup>71</sup> For dampers, a green LED is used to indicate Open and a yellow LED is used to indicate Closed. For fans, a green LED is used to indicate the ON state and a yellow LED is used to indicate the OFF state.<sup>72</sup> All trouble indicators use red LEDs. The visual indication requirements are:

- The Open and Closed positions of the central AHU supply, return, and exhaust air dampers (non-dedicated equipment).
- The ON and OFF status of the central AHU supply and return fans (nondedicated equipment).
- The Open and Closed positions of the exhaust air dampers (dedicated equipment) for each floor, 1st through 5th.
- A trouble indicator reflecting the ON (trouble) and OFF (normal) status of the exhaust air dampers for each floor, 1st through 5th. This is required since the exhaust dampers are considered dedicated equipment.
- The Open and Closed positions of the supply air dampers (combination dedicated and nondedicated equipment) for each floor, 1st through 5th. The closed position is determined solely by the "dedicated" supply air damper. The Open position is determined by the combination of the supply air damper being fully Open and all of the MNB-Vx controllers modulating their dampers (non-dedicated equipment) Open.
- A trouble indicator reflecting the ON (trouble) and OFF (normal) status of the supply air dampers for each floor, 1st through 5th. This is required since the supply dampers are considered dedicated equipment.
- A trouble indicator reflecting the ON (alarm) and OFF (normal) status of the smoke alarm for each smoke-control zone (1st through 5th floors).
- The ON and OFF status of the pressurization fans (dedicated equipment) for stairwells 1 and 2.
- A trouble indicator reflecting the ON (trouble) and OFF (normal) status of the pressurization fans for stairwells 1 and 2. This is required since the pressurization fans are considered dedicated equipment.
- A trouble indicator reflecting the ON (alarm) and OFF (normal) status of the smoke detector in the supply duct of each stairwell pressurization fan.

---

70.NFPA 92A, 2009 ed., chap. 6, para 6.4.3.7.10 and annex D, para D.1 (2).

71.NFPA 92A, 2009 ed., annex D, para D.1 (2).

72.NFPA 92A, 2009 ed., annex D, para D.1 (2) (a) and D.1 (2) (b).

- A system trouble indicator reflecting the ON (trouble) and OFF (normal) status of the smoke-control system. This indicator is illuminated if any trouble exists in the system.

## **Audible Annunciation**

All smoke alarm, dedicated trouble and general trouble indicators at the FSCS should also cause an audible annunciation of the condition to be generated.

## **Control Capability**

“The FSCS shall have the highest priority control over all smoke-control systems and equipment” <sup>73</sup> within the building. In this application, 3-position (ON-OFF-ON) toggle or rotary switches are used to provide control as follows:

- OPEN-AUTO-CLOSE control of the central AHU supply, return, and exhaust air dampers.
- ON-AUTO-OFF control of the central AHU supply and return fans.
- OPEN-AUTO-CLOSE control of the exhaust air dampers for each floor, 1st through 5th.
- OPEN-AUTO-CLOSE control of the supply air dampers for each floor, 1st through 5th.
- ON-AUTO-OFF control of the pressurization fans for stairwells 1 and 2.

## **Additional Control Requirements**

Provisions should be made at the FSCS for testing the visual indicators, providing audible device silencing and enabling/disabling the manual control capability of the FSCS. This would be done as follows:

- A manual override enable key switch that can enable and disable the functionality of the control switches mentioned previously. This will also enable and disable the audible device silence switch. A status indicator (i.e. green LED) is provided that will light when the FSCS override capability is enabled. The key associated with the switch should be non-removable when the FSCS is enabled.
- An audible device silence switch (momentary push-button) that is functional only when the FSCS is in the enable state.
- A lamp test switch (momentary push-button) for testing all LEDs on the FSCS. This switch will be enabled at all times.
- All status indicators remain operational regardless of the enabled/disabled state of the FSCS or the state of the control switches mentioned previously.

---

73.NFPA 92A, 2009 ed., chap. 6, para 6.4.3.7.11.

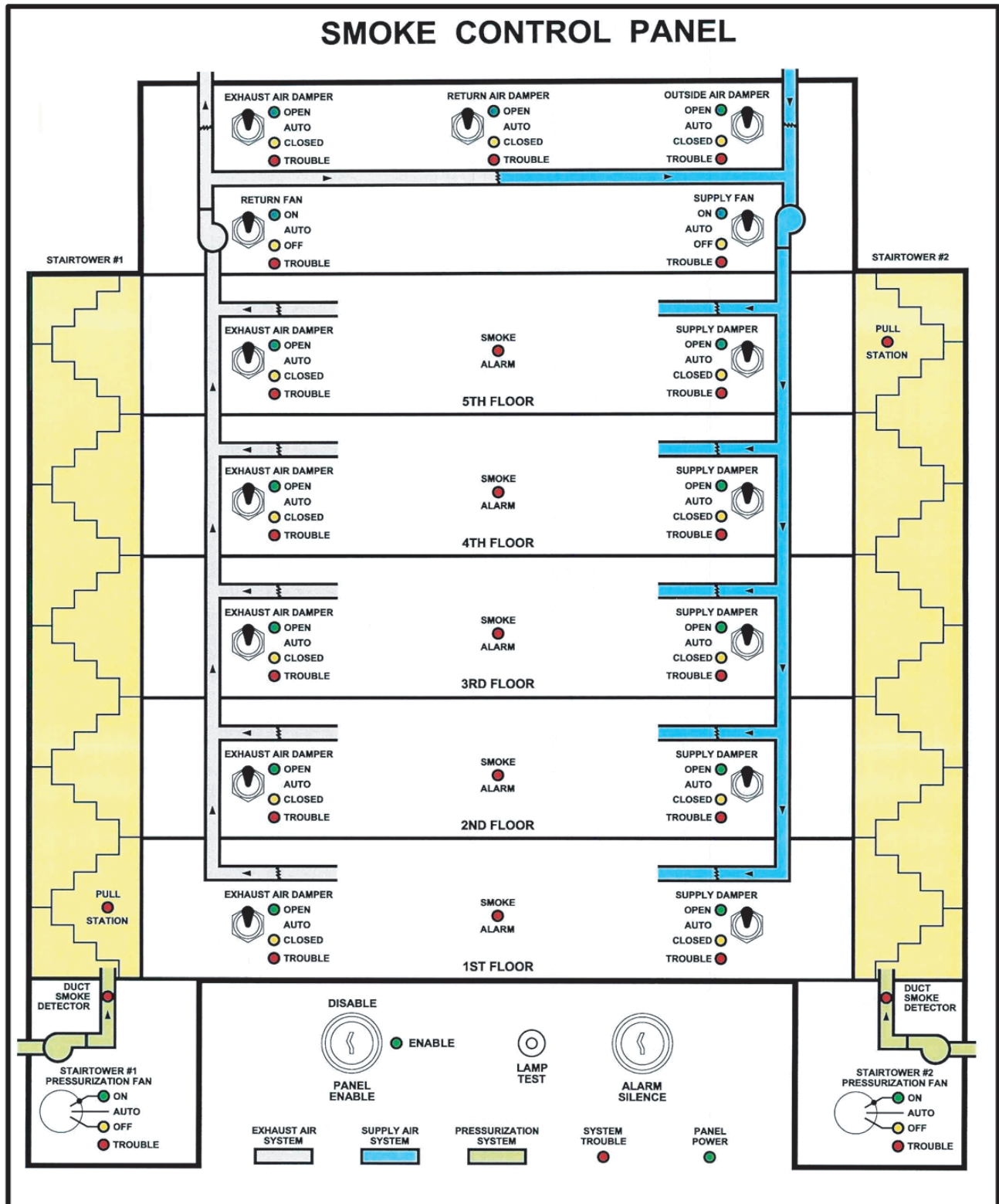

Figure-2.2 Firefighter's Smoke Control Station (FSCS).



## System Topologies

### MNB-1000 Controllers

The MNB-1000 (Instance 2000) controller provides a complete interface to the FSCS through its EIA-485 (RS-485) ADI ModBus interface. It is mounted inside the FSCS, along with its power supply. This controller is the master of the Smoke Control network since it monitors communications to all of the controllers that are part of the smoke-control system, distributes and receives global information between controllers in the network, initiates smoke-control sequences based on information received from the appropriate controllers, and provides additional HVAC control.

The MNB-1000 (Instance 1000) controller provides the central AHU control, monitors end process verification devices, distributes and receives global information between controllers in the network, monitors communications to all of the controllers beneath it, and initiates smoke-control sequences based on information received from the appropriate controllers. Its MS/TP communication trunk connects to the MNB-Vx controllers that provide HVAC control of the occupied spaces. These MNB-Vx controllers also control the common dedicated supply and exhaust air smoke dampers for each smoke-control zone.

The MNB-1000 (Instance 3000) controller monitors the damper proof-of-position for the dedicated supply and return air dampers associated with the smoke-control zones. Additionally, it distributes and receives global information between controllers in the network, monitors communications to all of the controllers beneath it, and initiates smoke-control sequences based on information received from the appropriate controllers. Its MS/TP communication trunk connects to the MNB-300 controllers that provide end process verification, control stairwell pressurization, and monitor smoke alarm and pull station contacts from the UOJZ Fire Alarm Panel. Other MS/TP BACnet controllers that are not UUKL Listed are connected to the same trunk, but are isolated from the UUKL Listed controllers through the use of an approved repeater. These other controllers provide HVAC control only.

### Ethernet/IP Infrastructure

Any UL 864 Listed IP infrastructure devices can be used to create the network topology. Currently, only the EIS8-100T and EIS6-100T/FT switching hubs from Contemporary Controls are available. The path through the Ethernet/IP network from any one UUKL device to another must use only UL 864 Listed infrastructure devices. The Ethernet/IP Smoke-Control System can coexist with the non-UL 864 networks as long as they are isolated from those networks through the use of UL 864 Listed IP infrastructure devices. Refer to Chapter 5, [Restrictions and General Comments](#), for additional information.

---

**Note:** At no time can any smoke control signals be passed over the public Internet.

---

## Wiring Requirements

Since the I/O wiring between the I/A Series BACnet controllers and the FSCS (when an I/O wiring interface is used) and the UOJZ Fire Alarm Panel is unsupervised, the I/A Series BACnet controllers used for this purpose must be mounted within 20 ft of the panel to which they are connected. The I/O wiring must be run in conduit. The table below (Table–2.2) lists the general requirements for the wiring associated with an I/A Series BACnet smoke-control application.

**Table–2.2 Wiring Requirements**

<b>Wiring</b>	<b>Status</b>
Ethernet/IP	Supervised by block programming
EIA-485 ADI ModBus	Supervised by block programming. When MNB-1000 is mounted external to the FSCS, wiring must be run in conduit and controller must be located within 20 ft. of the panel.
MS/TP Bus	Supervised by block programming
I/O to FSCS	Unsupervised, wiring must be run in conduit and controllers must be located within 20 ft. of the panel.
I/O to UOJZ FAP Contacts	Unsupervised, wiring must be run in conduit and controllers must be located within 20 ft. of the panel.
Remaining I/O	Unsupervised

## Central System Interface and Overlay Devices

When UNC, Web Server, and/or other central-system type interfaces are attached to the Ethernet/IP network with the ability to access the smoke-control system, they must be isolated from the network through the use of UL 864 Listed IP infrastructure devices (Figure–2.3). This isolation is required by UL because these devices, PC's and/or interfaces, are not UL 864 Listed. Therefore these devices cannot be used for smoke-control purposes.

Refer to Chapter 5, [Restrictions and General Comments](#), for additional information.

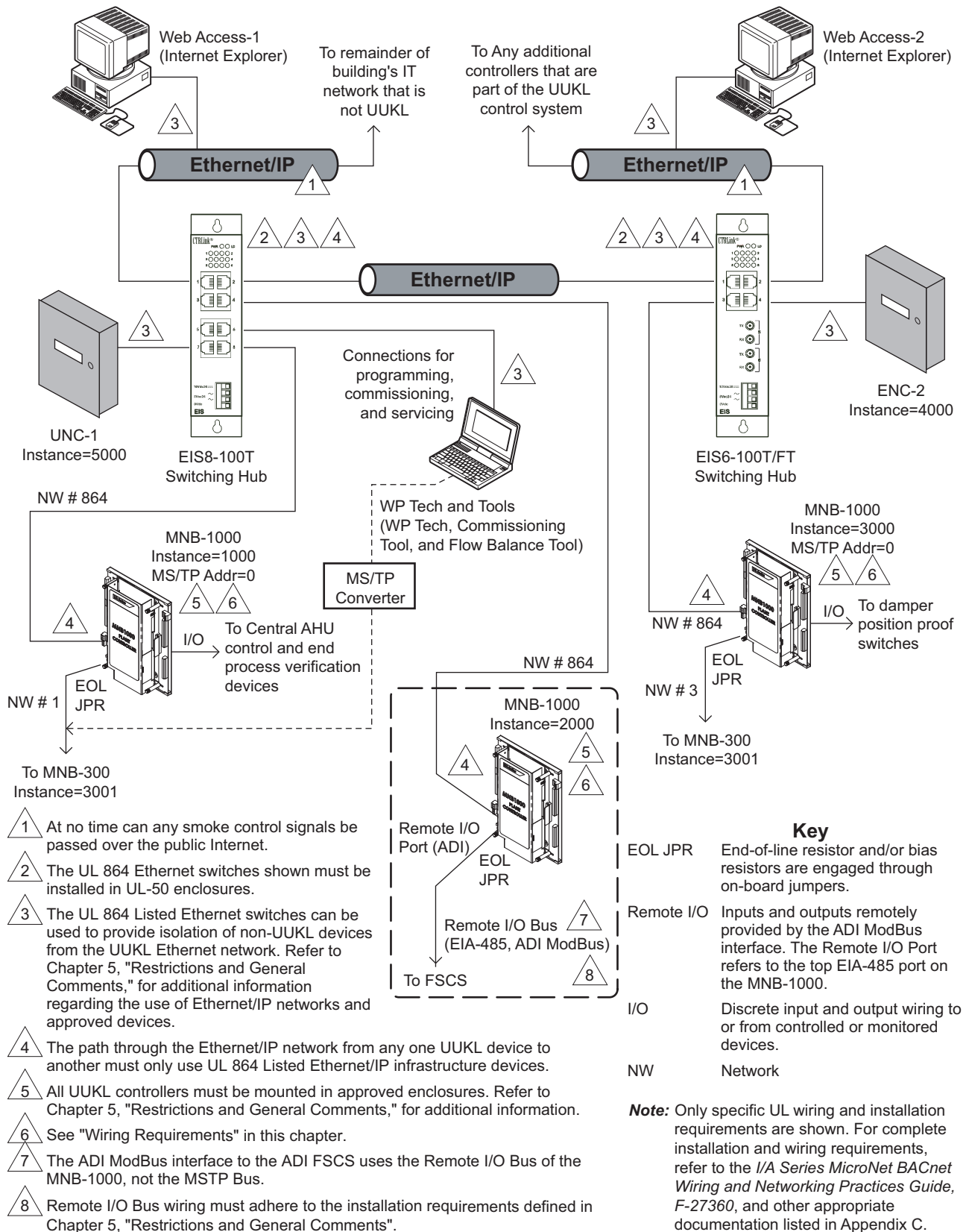

Figure-2.3 Ethernet/IP Network Topology.

## MNB-Vx Topology

In this application, each floor has eight MNB-Vx controllers that control the VAV terminal boxes (Figure–2.4). During normal occupied mode, each MNB-Vx modulates its primary damper and stages the electric reheat coils, as required, to maintain their individual zone temperature setpoints. During the unoccupied mode, the terminal boxes either maintain their respective unoccupied zone temperature setpoints or drive to a fixed position. Although the MNB-Vx controllers are controlling individual spaces within a floor, each complete floor is considered a smoke-control zone.

In some applications, when MNB-Vx controllers are used to control the supply air to a smoke-control zone, a separate supply air damper must be installed in the common supply duct to each floor/zone. These dampers are used in this application and are required to guarantee acceptable damper response times. The dedicated supply air damper is used to close the supply air to its respective floor when it is considered the smoke zone. Used in conjunction with the dedicated exhaust air damper, it causes the zone to become negatively pressurized. Otherwise, this damper is always fully open. In this example, these dampers are controlled by a spare DO point on an MNB-Vx associated with the respective smoke-control zone.

A separate exhaust air damper must be installed in the common exhaust duct to each floor or zone. The dedicated exhaust air damper is used to open the exhaust air to its respective floor when it is considered the smoke zone. Used in conjunction with the dedicated return air damper, it causes the zone to become negatively pressurized. Otherwise, this damper is always fully open. The exhaust dampers are also controlled by a spare DO point on an MNB-Vx associated with the respective smoke-control zone.

The MNB-Vx controllers modulate their terminal box primary air dampers, as required, to provide positive pressurization to all smoke-control zones.

---

**Note:** The UL acceptance of the MNB-V1 and MNB-V2 controllers for UUKL is based on the assumption that negative pressurization of a smoke zone is considered accomplished when the total CFM flow supplied to the zone drops below 50% of its maximum with its dedicated exhaust damper fully open. Sufficient differential pressure must be achieved to ensure smoke spread is confined to the zone in which the fire originated. In all cases, exhaust and supply air dampers should continue to be driven to their full-open and full-closed positions.

---

## MS/TP Bus Requirements

Typically, MS/TP repeaters are used to provide isolation between UUKL Listed and non-UUKL Listed devices, or to extend the maximum distance of the bus. The MS/TP bus can support up to a maximum of 128 devices. Because each TAC I/A Series MicroNet BACnet controller is only a 1/4-load node, a repeater is not necessary to support the maximum number of nodes, or to increase the number of nodes that can be connected to the bus. In cases where third-party devices are involved, a repeater may be used to increase the number of devices that can be connected to the bus. In the application discussed here, the B-LINK-AC-S repeater is used to extend the distance of the MS/TP bus.

For additional repeater information, refer to Chapter 5, [Restrictions and General Comments](#).



**Note:** Only specific UL wiring and installation requirements are shown. For complete installation and wiring requirements, refer to the *I/A Series MicroNet BACnet Wiring and Networking Practices Guide, F-27360*, and other appropriate documentation listed in Appendix C.

**Note:** All references to the MNB-V1 equally apply to the MNB-V1-2 and all references to the MNB-V2 equally apply to the MNB-V2-2.

**Key**

EOL End-of-line resistor, 120 Ω (part number EMSC-546). To MNB-1000 (Instance=1000) ←

\* See "MS/TP Requirements" in this chapter.

Figure-2.4 MNB-V1 and MNB-V2 Controller Topology.

## **MNB-1000 Interface to FSCS**

The MNB-1000 (Instance 2000) controller provides a complete interface to the FSCS through its EIA-485 (RS-485) ADI ModBus interface (Figure–2.5). It controls all the FSCS LEDs and monitors all the FSCS override switches. The FSCS (panel) Enable switch functionality is also enforced through programming in the MNB-1000 controller. Refer to Chapter 5, [Restrictions and General Comments](#), for an example of this programming and for additional information on the FSCS interface.

When interfaced to the ADI FSCS, the MNB-1000 controller and its power supply are mounted inside the FSCS enclosure, eliminating the need for separate enclosures. This controller functions as the master of the smoke-control network. It monitors communications to all of the controllers that are part of the smoke-control system, distributes and receives global information between controllers in the network, initiates smoke-control sequences based on information received from the appropriate controllers, and integrates the FSCS functionality into the system. Optionally, it can also perform HVAC control functions.

---

**Note:** When using I/O points to interface to a UL 864 UUKL/UUKL7 Listed FSCS in place of using an ADI FSCS that supports the ADI ModBus protocol, many additional controllers will be required. Each installation must be carefully assessed to ensure that adequate quantities of devices have been allotted, to perform the necessary control and monitoring functions. Refer to "[Job Estimating](#)" on [page 78](#) for point calculating specifics.

---

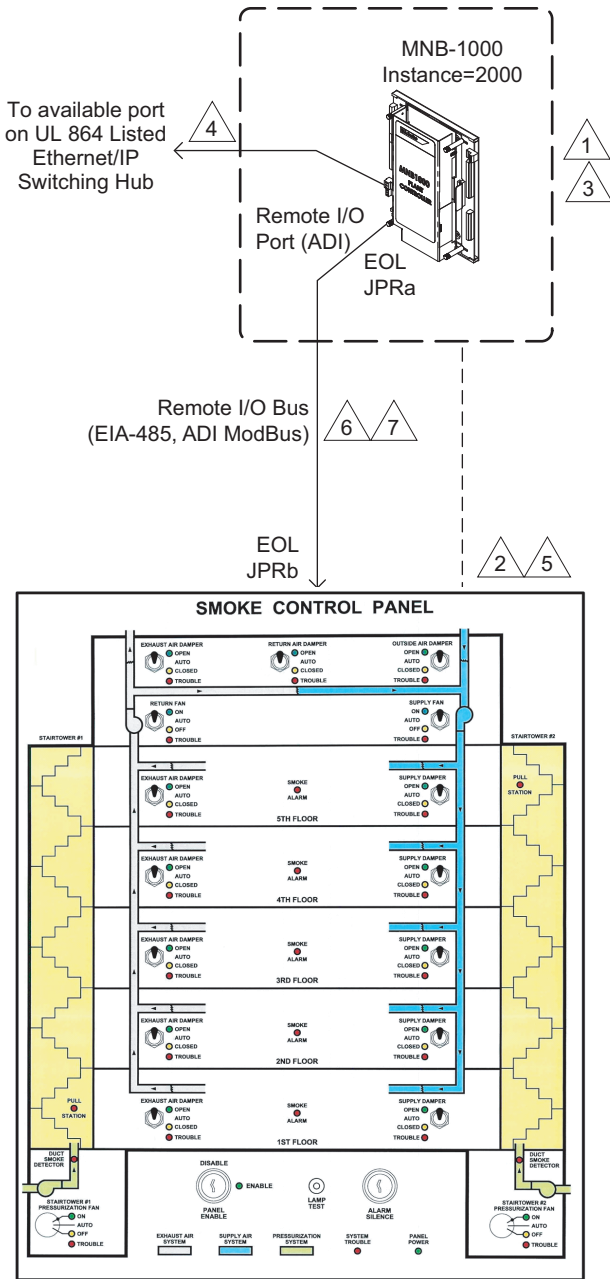

- 1 In this example, the MNB-1000 controller shown is mounted inside the ADI FSCS enclosure, along with its dedicated power supply. This is an option that can be specified when ordering the ADI FSCS. Refer to Chapter 5, "Restrictions and General Comments," for additional information regarding the FSCS.
- 2 The UOJZ Listed N.O. contacts from the Fire Alarm Panel (FAP) are wired to MNB-300 controllers. As an option, additional contact inputs can be specified when ordering the ADI FSCS, allowing the FAP contacts to be wired directly to the FSCS. Should this option be used, these controllers *must* be mounted within 20 ft. of the FAP, and the I/O wiring *must* be run in conduit because the I/O wiring between the FAP and the FSCS is unsupervised.
- 3 All UUKL controllers must be mounted inside approved enclosures. Refer to Chapter 5, "Restrictions and General Comments" for additional information. When the ADI FSCS is ordered with the MNB-1000 and its power supply mounted internally, no additional enclosures are required.
- 4 The path through the Ethernet/IP network from any one UUKL device to another must only use UL 864 Listed Ethernet/IP infrastructure devices.
- 5 If individual controllers use hard-wired I/O points to interface to the FSCS, these controllers *must* be mounted within 20 ft. of the FAP, and the I/O wiring *must* be run in conduit because the I/O wiring is unsupervised.
- 6 The ADI ModBus interface to the ADI FSCS uses the Remote I/O Bus of the MNB-1000, not the MSTP Bus.
- 7 Remote I/O Bus wiring must adhere to the installation requirements defined in Chapter 5, "Restrictions and General Comments".

### Key

- EOL JPRa End-of-line resistor is engaged through an on-board jumper on the MNB-1000. Refer to the *MicroNet BACnet MNB-1000 Plant Controller Installation Instructions*, F-27347, for additional information.
- Remote I/O Inputs and outputs remotely provided by the ADI ModBus interface. The Remote I/O Port refers to the top EIA-485 port on the MNB-1000.
- EOL JPRb End-of-line resistor is engaged through an on-board jumper on the ADI FSCS. Refer to the documentation shipped with the unit.

**Note:** Only specific UL wiring and installation requirements are shown. For complete installation and wiring requirements, refer to the *I/A Series MicroNet BACnet Wiring and Networking Practices Guide*, F-27360, and other appropriate documentation listed in Appendix C.

Figure-2.5 MNB-1000 Interface to FSCS.

## Fire Alarm Panel Interface and Remaining System Topology

The MNB-1000 (Instance 3000) and the controllers beneath it provide additional controlling and monitoring functions, as well as the Fire Alarm Panel (FAP) interface. These controllers operate as follows:

- The MNB-1000 (Instance 3000) controller monitors the damper proof-of-position switches for the five dedicated supply air dampers and three of the dedicated exhaust air dampers associated with the smoke-control zones. It distributes and receives global information between controllers in the network, monitors communications to all of the controllers beneath it, and initiates smoke-control sequences based on information received from the appropriate controllers.
- The MNB-300 (Instance 3001) controller monitors the damper proof-of-position switches for the remaining two dedicated exhaust air dampers associated with the smoke-control zones. It distributes them to the remaining controllers as required for smoke-control purposes.
- The MNB-300 (Instance 3002) controller interfaces to the UOJZ Fire Alarm Panel to monitor stairwell duct smoke alarm and pull station contacts. It provides control of the stairwell pressurization systems and receives or distributes information to or from controllers as required for smoke-control purposes.
- The MNB-300 (Instance 3003) controller also interfaces to the UOJZ Fire Alarm Panel to monitor smoke alarm contacts associated with Floors 1-5. It distributes this information to controllers as required for smoke-control purposes.
- The B-LINK-AC MS/TP repeater is used to extend the distance of the MS/TP bus and provide isolation between UUKL and non-UUKL Listed devices. In this example, its main purpose is to isolate the trunk from non-UUKL Listed controllers that are used for HVAC purposes and perform no functions associated with smoke control.
- The remaining two devices (Instances 3004 and 3005), are not UUKL Listed. They are isolated from the UUKL Listed controllers through use of the B-LINK-AC repeater. These controllers perform HVAC functions that are unrelated to smoke control.



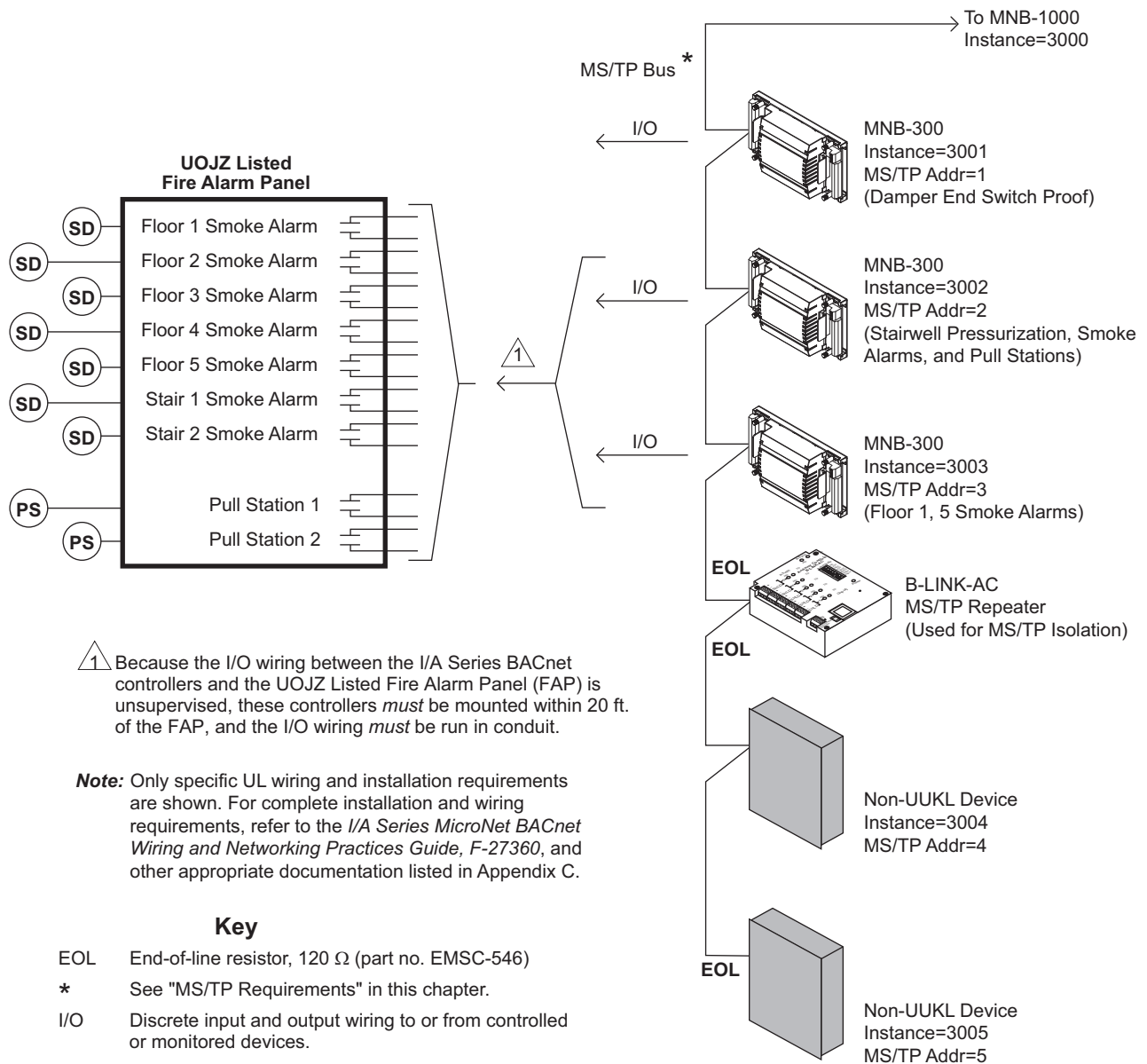

Figure–2.6 Fire Alarm Panel and Remaining Controllers.

## Comments

Always refer to the NFPA 92A, NFPA 92B, NFPA 72, and UL 864 UUKL/UUKL7 standards for additional Smoke-Control Systems information. Additionally, general system application comments and restrictions are provided in Chapter 5, [Restrictions and General Comments](#) and should be thoroughly reviewed to ensure compliance with the UL listing. It is the responsibility of the field office to work with the smoke-control system designer and gain the smoke-control system approval from the Authority Having Jurisdiction (AHJ).



---

# **Chapter 3**

## **Warehouse Smoke Control**

### **Purpose**

This application provides guidelines for using I/A Series Micronet BACnet controllers in a single story warehouse (or similar single-story buildings with large open spaces) that require the UL 864 UUKL/UUKL7 listing for Smoke-Control Systems. This application utilizes only nondedicated smoke-control equipment. Multiple MNB-1000 controllers are used to perform the HVAC functions when in normal control mode. When in the smoke-control mode, they perform the required smoke-control sequences by controlling the individual air handling unit (AHU) fans and dampers (supply, exhaust, and return). One MNB-1000 controller monitors the N.O. relay contacts of a UOJZ Listed fire alarm panel for automatic activation of the smoke-control sequences, and monitors the UUKL Listed Firefighter's Smoke Control Station (FSCS) for manual activation and overrides. This controller also provides control of the FSCS visual and audible status indicators.

### **Sequence of Operation**

#### **Normal HVAC Control**

Under normal conditions, each AHU follows an occupied schedule that determines when that AHU operates. In the case of the warehouse, a central occupied schedule is used for all of the units. During the unoccupied mode, the outdoor and exhaust air dampers are in the full-closed positions. The return air dampers are in the full-open positions. The supply and return fans are commanded OFF. During the occupied mode, the supply and return fans are commanded ON. The outdoor, exhaust, and return air dampers modulate in conjunction with typical heating and/or cooling coils or equipment to maintain the zone temperature setpoint associated with the respective AHU.

Each AHU can have a wide variety of additional control sequences that determine its operation and establish its operating priorities (for example, low limit stats and minimum outdoor air). One MNB-1000 controller is used for each AHU. Each one provides the basic control of the AHU and the monitoring of end process verification sensors, such as flow switches and position indication switches.

The Fire Alarm Panel (i.e. Listed Fire Alarm Control Unit) is the primary indicator for fire alarm conditions. It is also the primary initiator of the automatic smoke/fire alarm sequence. Upon detection of smoke or fire, a set of contacts in the Fire Alarm Panel (for the zone affected) close, indicating to the I/A Series BACnet building automation system that a smoke/fire condition exists. In this application, a smoke detector is provided for each zone (smoke-control zone) and each zone consists of the area served by a single AHU. The contacts from the Fire Alarm Panel for the associated smoke detectors are monitored by the MNB-1000 controller associated with the FSCS.

---

**Note:** Any UOJZ listed fire alarm panel with programmable N.O. relay contacts can be used with I/A Series BACnet controllers.

---

The Automation Displays, Inc. Firefighter's Smoke Control Station (i.e. Listed Smoke Control Panel) is the primary indicator for the status of all smoke control and related HVAC equipment. It also provides the interface for manual activation commands and overrides for all smoke-control related equipment. An MNB-1000 controller is mounted internal to the FSCS and provides the ADI ModBus (control) interface to the FSCS. This controller is the central coordinator of all smoke-control activity. All commands issued from the FSCS are monitored and distributed throughout the network as required to implement the manual smoke-control sequences and overrides. The status of all of the smoke-control systems and equipment, as well as HVAC monitored trouble signals, are returned to the FSCS for visual indication and, in some cases, audible annunciation. Spare I/O points that exist on this controller may be used for other control purposes, if required.

---

**Note:** Any UUKL listed FSCS can be used with I/A Series BACnet controllers, but only the Automation Displays, Inc. unit supports the ADI ModBus interface. When an FSCS from other vendors is used, many additional controllers will be required to provide the individual I/O point interfaces.

---

In this application, the complete smoke-control system is considered nondedicated. Therefore, the smoke-control equipment does not require an automatic self-test. Since this equipment consists of HVAC components that are operated on a regular basis, the normal "comfort" level associated with the operability or inoperability of the equipment is considered an acceptable means of maintaining system integrity. Fan operation is verified using differential pressure sensors. Supply, exhaust, and return air damper positions are verified by monitoring end-of-travel switches.

## Smoke Control Sequences

This application uses only one type of smoke-control system to implement the smoke-control strategy. This system consists of zoned smoke control. Zoned smoke control divides a building into a number of zones for the purpose of inhibiting smoke movement.<sup>74</sup> The zones are separated from each other by smoke barriers. In the event of a fire, pressure differences and airflows produced by mechanical fans and operating dampers are used to limit the smoke to the zone in which the fire originated.<sup>75</sup>

---

74. National Fire Protection Association, Inc., NFPA 92A, *Standard for Smoke-Control Systems Utilizing Barriers and Pressure Differences*, NFPA 92A, 2009 ed., chap. 5, para. 5.5.1.1.

Each area of the warehouse that is served by an AHU is considered a smoke-control zone. When smoke is detected in any zone, all of the nonsmoke zones that are contiguous to the smoke zone, or optionally, all nonsmoke zones in the building,<sup>76</sup> are positively pressurized and the smoke is exhausted from the smoke zone. Pressurization of the noncontiguous (optional) smoke-control zones is dependent upon the smoke-control system design and its associated specification. Regardless of whether or not the noncontiguous smoke-control zones are positively pressurized, sufficient differential pressure must be achieved to limit smoke spread to the zone in which the fire originated.

Anytime a smoke/fire detector trips, an automatic smoke-control sequence is initiated. For example, if the smoke/fire detector for smoke-control Zone 5 trips first, the automatic smoke-control sequence is initiated in the following manner:

1. The AHU-5 supply fan is commanded OFF and the return fan is commanded ON. The return and outdoor air dampers are driven to their full-closed positions. The exhaust air damper is driven to the full-open position. This prevents any outdoor or return air from being delivered, by AHU-5, to the zone reporting the smoke condition. It also allows maximum exhausted air to be expelled from the smoke zone.
2. The AHU-1, AHU-2, AHU-3, AHU-4, and AHU-6 supply fans are commanded ON and their return fans are commanded OFF. Their associated return and exhaust air dampers are driven to the full-closed positions. Their outdoor air dampers are driven full-open. This allows outdoor air to be delivered to each of the smoke-control zones that are contiguous to the zone reporting the smoke condition. This fresh air is used to positively pressurize the nonsmoke zones.
3. The automatic smoke-control sequence takes priority over the normal HVAC control sequences and any HVAC control overrides. Static pressure high limits and duct smoke detectors on supply air systems should not be automatically overridden.<sup>77</sup>
4. Once the automatic activation has occurred, subsequent alarm signals that would normally initiate an automatic smoke-control sequence will annunciate only. (For example if, in addition to the AHU-5 smoke/fire detector, the AHU-6 detector also trips, no change to the smoke-control sequence occurs and the AHU-6 smoke condition also annunciates at the FSCS.)
5. At any time, the FSCS is capable of overriding either partially, or in full, any automatic activation of a smoke-control sequence that may be in process.<sup>78</sup>
6. The communications between all of the I/A Series BACnet controllers that are part of the smoke-control sequences must be monitored. If the communications between any of these controllers fails, at any time, the system trouble LED at the FSCS must illuminate and an audible signal must be generated.<sup>79</sup>

---

75.NFPA 92A, 2009 ed., annex A, para. A.5.5.

76.NFPA 92A, 2009 ed., annex A, para. A.5.5.1.1.1.

77.NFPA 92A, 2009 ed., chap. 6, para's 6.4.2 and 6.4.5.2.1.2.

78.NFPA 92A, 2009 ed., chap. 6, para 6.4.3.7.11.

7. If any of the smoke-control equipment proof sensors fail to operate within a specified period of time during the smoke-control sequence or when under control of the FSCS, the system trouble LED at the FSCS illuminates and an audible signal is generated.

If the smoke/fire detector for AHU-6 trips first, the automatic smoke-control sequence is initiated in the following manner:

1. The AHU-6 supply fan is commanded OFF and the return fan is commanded ON. The return and outdoor air dampers are driven to their full-closed positions. The exhaust air damper is driven to the full-open position. This prevents any outdoor or return air from being delivered, by AHU-6, to the zone reporting the smoke condition. It also allows maximum exhausted air to be expelled from the smoke zone, and negative pressurization in the area where the smoke was detected.
2. The AHU-1, AHU-2, AHU-3, AHU-4 and AHU-5 supply fans are commanded ON and their return fans are commanded OFF. Their associated return and exhaust air dampers are driven to the full-closed positions. The outdoor air dampers are driven full-open. This allows outdoor air to be delivered to each of the smoke-control zones. This outdoor air is used to positively pressurize the nonsmoke zones. Controlling AHU-3 and AHU-4 in this manner is considered optional since these zones are not contiguous to the smoke zone.
3. The automatic smoke-control sequence takes priority over the normal HVAC control sequences and any HVAC control overrides. Static pressure high limits and duct smoke detectors on supply air systems should not be automatically overridden.<sup>80</sup>
4. Once the automatic activation has occurred, subsequent alarm signals that would normally initiate an automatic smoke-control sequence will annunciate only. (For example if, in addition to the AHU-6 smoke/fire detector, the AHU-2 detector also trips, no change to the smoke-control sequence occurs and the AHU-2 smoke condition also annunciates at the FSCS.)
5. At any time, the FSCS is capable of overriding either partially, or in full, any automatic activation of a smoke-control sequence that may be in process.<sup>81</sup>
6. The communications between all of the I/A Series BACnet controllers that are part of the smoke-control sequences must be monitored. If the communications between any of these controllers fails, at any time, the system trouble LED at the FSCS must illuminate and an audible signal must be generated.<sup>82</sup>
7. If any of the smoke-control equipment proof sensors fail to operate within a specified period of time during the smoke-control sequence or when under control of the FSCS, the system trouble LED at the FSCS illuminates and an audible signal is generated.

---

79. Underwriters Laboratories Inc., UL 864, *Control Units and Accessories for Fire Alarm Systems*, 9th ed. (2003), para's 48.5, 49.4, 49.6, and 49.7.

80. NFPA 92A, 2009 ed., chap. 6, para's 6.4.2 and 6.4.5.2.1.2.

81. NFPA 92A, 2009 ed., chap. 6, para 6.4.3.7.11.

82. UL 864, 9th ed., para's 48.5, 49.4, 49.6, and 49.7.

## Smoke-Control System Configuration Schedule

Each smoke-control system configuration should be defined in a schedule.<sup>83</sup> The schedule should list all dedicated and nondedicated equipment and show the equipment response for each sensor that activates an automatic smoke-control sequence. An example schedule for this application is shown below (Table–3.1).

**Note:**

- According to NFPA 92A, only the smoke zones that are contiguous to the zone reporting the smoke condition have to be positively pressurized. For this application, all non-smoke zones are being positively pressurized.
- Pressurization of the noncontiguous (optional) smoke-control zones is dependent upon the smoke-control system design and its associated specification. Regardless of whether or not noncontiguous smoke-control zones are positively pressurized, sufficient differential pressure must be achieved to ensure smoke spread is confined to the zone in which the fire originated.

**Table–3.1 Schedule for Smoke-Control System Configuration .**

Nondedicated Smoke Control Equipment	Zone 1 Smoke Detector in Alarm	Zone 2 Smoke Detector in Alarm	Zone 3 Smoke Detector in Alarm	Zone 4 Smoke Detector in Alarm	Zone 5 Smoke Detector in Alarm	Zone 6 Smoke Detector in Alarm
AHU-1 Supply Fan	OFF	ON	ON	ON	ON	ON
AHU-1 Return Fan	ON	OFF	OFF	OFF	OFF	OFF
AHU-1 O.A. Damper	Full Closed	Full Open	Full Open	Full Open	Full Open	Full Open
AHU-1 Return Damper	Full Closed	Full Closed	Full Closed	Full Closed	Full Closed	Full Closed
AHU-1 Exhaust Damper	Full Open	Full Closed	Full Closed	Full Closed	Full Closed	Full Closed
Smoke Control Zone 1	Neg. Press.	Pos. Press.	Pos. Press.	Pos. Press.	Pos. Press.	Pos. Press.
AHU-2 Supply Fan	ON	OFF	ON	ON	ON	ON
AHU-2 Return Fan	OFF	ON	OFF	OFF	OFF	OFF
AHU-2 O.A. Damper	Full Open	Full Closed	Full Open	Full Open	Full Open	Full Open
AHU-2 Return Damper	Full Closed	Full Closed	Full Closed	Full Closed	Full Closed	Full Closed
AHU-2 Exhaust Damper	Full Closed	Full Open	Full Closed	Full Closed	Full Closed	Full Closed
Smoke Control Zone 2	Pos. Press.	Neg. Press.	Pos. Press.	Pos. Press.	Pos. Press.	Pos. Press.
AHU-3 Supply Fan	ON	ON	OFF	ON	ON	ON
AHU-3 Return Fan	OFF	OFF	ON	OFF	OFF	OFF
AHU-3 O.A. Damper	Full Open	Full Open	Full Closed	Full Open	Full Open	Full Open
AHU-3 Return Damper	Full Closed	Full Closed	Full Closed	Full Closed	Full Closed	Full Closed
AHU-3 Exhaust Damper	Full Closed	Full Closed	Full Open	Full Closed	Full Closed	Full Closed
Smoke Control Zone 3	Pos. Press.	Pos. Press.	Neg. Press.	Pos. Press.	Pos. Press.	Pos. Press.
AHU-4 Supply Fan	ON	ON	ON	OFF	ON	ON
AHU-4 Return Fan	OFF	OFF	OFF	ON	OFF	OFF
AHU-4 O.A. Damper	Full Open	Full Open	Full Open	Full Closed	Full Open	Full Open
AHU-4 Return Damper	Full Closed	Full Closed	Full Closed	Full Closed	Full Closed	Full Closed
AHU-4 Exhaust Damper	Full Closed	Full Closed	Full Closed	Full Open	Full Closed	Full Closed

83.NFPA 92A, 2009 ed., chap. 6, para 6.4.5.3 and annex A, para A.6.4.5.3.

Table–3.1 Schedule for Smoke-Control System Configuration (Continued).

Nondedicated Smoke Control Equipment	Zone 1 Smoke Detector in Alarm	Zone 2 Smoke Detector in Alarm	Zone 3 Smoke Detector in Alarm	Zone 4 Smoke Detector in Alarm	Zone 5 Smoke Detector in Alarm	Zone 6 Smoke Detector in Alarm
Smoke Control Zone 4	Pos. Press.	Pos. Press.	Pos. Press.	Neg. Press.	Pos. Press.	Pos. Press.
AHU-5 Supply Fan	ON	ON	ON	ON	OFF	ON
AHU-5 Return Fan	OFF	OFF	OFF	OFF	ON	OFF
AHU-5 O.A. Damper	Full Open	Full Open	Full Open	Full Open	Full Closed	Full Open
AHU-5 Return Damper	Full Closed	Full Closed	Full Closed	Full Closed	Full Closed	Full Closed
AHU-5 Exhaust Damper	Full Closed	Full Closed	Full Closed	Full Closed	Full Open	Full Closed
Smoke Control Zone 5	Pos. Press.	Pos. Press.	Pos. Press.	Pos. Press.	Neg. Press.	Pos. Press.
AHU-6 Supply Fan	ON	ON	ON	ON	ON	OFF
AHU-6 Return Fan	OFF	OFF	OFF	OFF	OFF	ON
AHU-6 O.A. Damper	Full Open	Full Open	Full Open	Full Open	Full Open	Full Closed
AHU-6 Return Damper	Full Closed	Full Closed	Full Closed	Full Closed	Full Closed	Full Closed
AHU-6 Exhaust Damper	Full Closed	Full Closed	Full Closed	Full Closed	Full Closed	Full Open
Smoke Control Zone 6	Pos. Press.	Pos. Press.	Pos. Press.	Pos. Press.	Pos. Press.	Neg. Press.

## Firefighter’s Smoke Control Station (FSCS)

The requirements of the FSCS are similar to the ones shown in Chapter 2. The graphic depiction and smoke-control equipment used changes based on the sequence of operation for this application.

## System Topologies

### Warehouse Building Layout

In this application there are six individual AHUs, with each controlling the space temperatures for their associated zone (Figure–3.1 and Figure–3.2). Each AHU is controlled by a single MNB-1000 controller. These devices (Instances 10 through 60) monitor and control all of the I/O points that provide the normal HVAC control (including control priorities such as low limit stats, filter, etc.). Additionally, the end process verification sensors for the smoke-control equipment are monitored. These sensors would typically consist of flow switches and end switches that are associated with the supply and return fans, as well as the supply, return, and exhaust dampers. The proof sensor information is distributed throughout the network as required to perform the smoke-control strategies and update the FSCS. Events that initiate automatic and manual activation of smoke-control strategies are monitored by a separate MNB-1000 (Instance 70) controller in the network. It distributes the information to these controllers for implementation and subsequent feedback. Each zone controlled by an AHU is considered a smoke-control zone; therefore, the warehouse has six smoke-control zones.

The MNB-1000 (Instance 70) controller provides a complete interface to the FSCS through its EIA-485 (RS-485) ADI ModBus interface. It is mounted inside the FSCS, along with its power supply. This controller functions as the master of the Smoke Control network because it monitors communications to all the controllers that are part of the smoke-control system, distributes and receives



global information between controllers in the network, initiates smoke-control sequences based on information received from the appropriate controllers, and provides additional HVAC control.

## Ethernet/IP Infrastructure

Any UL 864 Listed IP infrastructure devices can be used to create the network topology. Currently, the only available units are the EIS8-100T and EIS6-100T/FT switching hubs from Contemporary Controls. The path through the Ethernet/IP network from any one UUKL device to another must use only UL 864 Listed infrastructure devices. The Ethernet/IP Smoke-Control System can coexist with the non-UL 864 networks, as long as they are isolated from those networks through the use of UL 864 Listed IP infrastructure devices. Refer to Chapter 5, [Restrictions and General Comments](#), for additional information.

**Note:** At no time can any smoke control signals be passed over the public Internet.

## Wiring Requirements

Since the I/O wiring between the I/A Series BACnet controllers and the FSCS (when an I/O wiring interface is used) and the UOJZ Fire Alarm Panel is unsupervised, the I/A Series BACnet controllers used for this purpose must be mounted within 20 ft of the panel to which they are connected. The I/O wiring must be run in conduit. [Table–3.2](#), below, lists the general requirements for the wiring associated with an I/A Series BACnet smoke-control application.

**Table–3.2 Wiring Requirements.**

Wiring	Status
Ethernet/IP	Supervised by block programming
EIA-485 ADI ModBus	Supervised by block programming. When MNB-1000 is mounted external to the FSCS, wiring must be run in conduit and controller must be located within 20 ft. of the panel.
MS/TP Bus	Supervised by block programming
I/O to FSCS	Unsupervised, wiring must be run in conduit and controllers must be located within 20 ft. of the panel.
I/O to UOJZ FAP Contacts	Unsupervised, wiring must be run in conduit and controllers must be located within 20 ft. of the panel.
Remaining I/O	Unsupervised

## Central System Interface and Overlay Devices

When a UNC, Web Server, and/or other central-system type interfaces are attached to the Ethernet/IP network with the ability to access the smoke-control system, they must be isolated from the network through the use of UL 864 Listed IP infrastructure devices ([Figure–3.2](#)). This isolation is required by UL because these devices, PC's and/or interfaces, are not UL 864 Listed. Therefore these devices cannot be used for smoke-control purposes.

Refer to Chapter 5, [Restrictions and General Comments](#), for additional information.

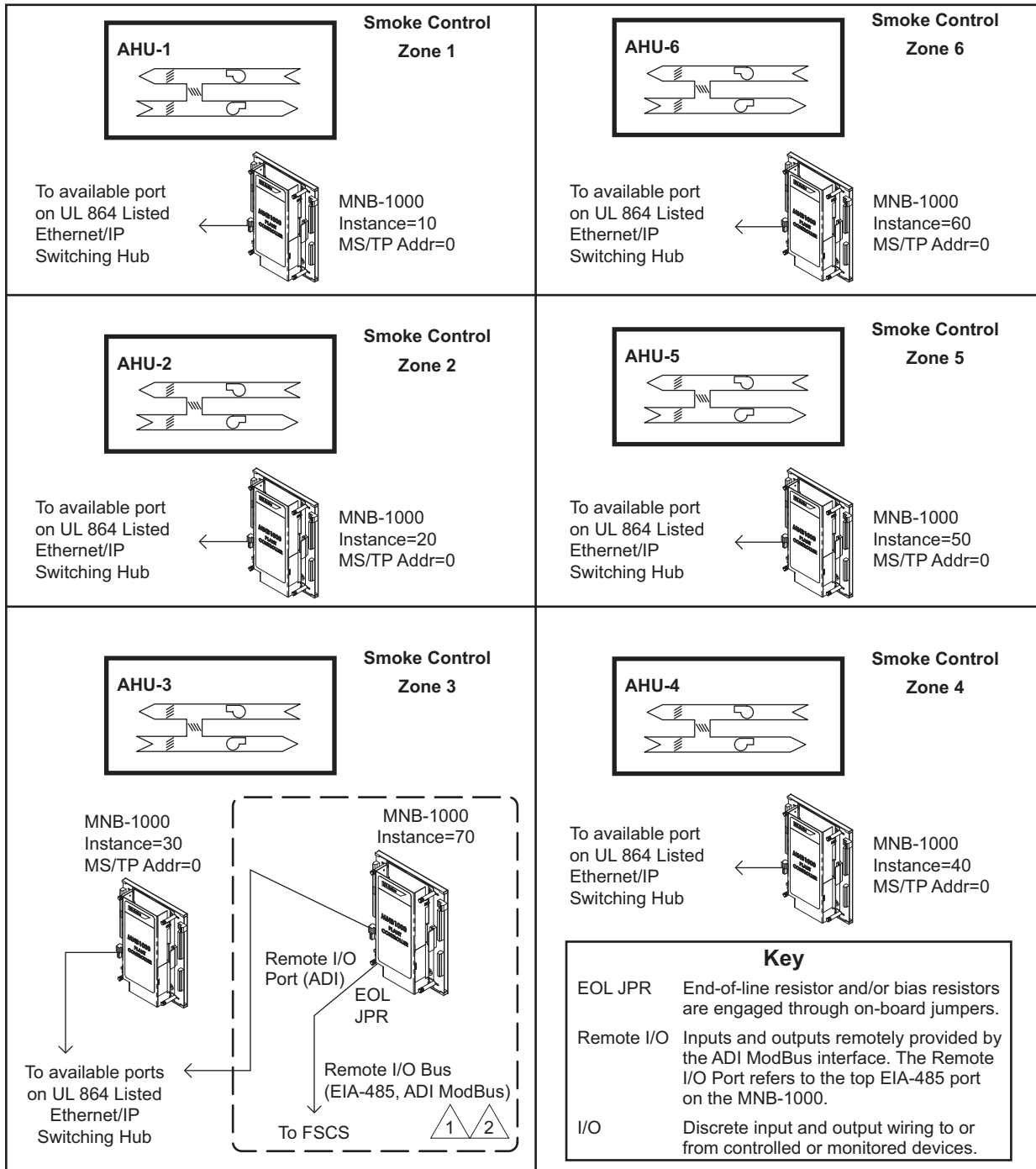

**Note:** Only specific UL wiring and installation requirements are shown. For complete installation and wiring requirements, refer to the *I/A Series MicroNet BACnet Wiring and Networking Practices Guide, F-27360*, and other appropriate documentation listed in Appendix C.

- 1 The ADI ModBus interface to the ADI FSCS uses the Remote I/O Bus of the MNB-1000, not the MSTP Bus.
- 2 Remote I/O Bus wiring must adhere to the installation requirements defined in Chapter 5, "Restrictions and General Comments".

Figure–3.1 Warehouse Building Layout.

## MNB-1000 Interface to FSCS

The MNB-1000 (Instance 70) controller provides a complete interface to the FSCS through its EIA-485 (RS-485) ADI ModBus interface (Figure–3.3). It controls all the FSCS LEDs and monitors all the FSCS override switches. The FSCS (panel) Enable switch functionality is also enforced through programming in the MNB-1000 controller. Refer to Chapter 5, [Restrictions and General Comments](#) for an example of this programming and for additional information on the FSCS interface.

When interfaced to the ADI FSCS, the MNB-1000 controller and its power supply are mounted inside the FSCS enclosure, eliminating the need for separate enclosures. This controller functions as the master of the smoke-control network. It monitors communications to all of the controllers that are part of the smoke-control system, distributes and receives global information between controllers in the network, initiates smoke-control sequences based on information received from the appropriate controllers, and integrates the FSCS functionality into the system. Optionally, it can also perform HVAC control functions.

---

**Note:** When using I/O points to interface to a UL 864 UUKL/UUKL7 Listed FSCS in place of using an ADI FSCS that supports the ADI ModBus protocol, many additional controllers will be required. Each installation must be carefully assessed to ensure that adequate quantities of devices have been allotted to perform the necessary control and monitoring functions. Refer to "[Job Estimating](#)" on page 78 for point calculating specifics.

---

## Fire Alarm Panel Interface

The UOJZ Listed N.O. contacts from the Fire Alarm Panel are wired directly to contact inputs of the FSCS (Figure–3.3). When ordering the ADI FSCS, contact inputs can be specified for this purpose. When this option is used, the FSCS and the FAP device supplying the contacts must be mounted within 20 ft. of each other, and the I/O wiring must be run in conduit because the I/O wiring is unsupervised.

When the FAP is interfaced to the FSCS in this manner, the statuses of the smoke alarms are received from the FSCS by the MNB-1000 (Instance 70) controller and distributed throughout the network, as required, to support the smoke-control sequence.

---

**Note:** When using controller I/O points to interface to UOJZ Listed N.O. contacts from a Fire Alarm Panel (instead of contact inputs of the ADI FSCS), several additional controllers will be required. Each installation must be carefully assessed to ensure that adequate quantities of devices have been allotted to perform the necessary control and monitoring functions. Refer to "[Job Estimating](#)" on page 78 for point calculating specifics.

---

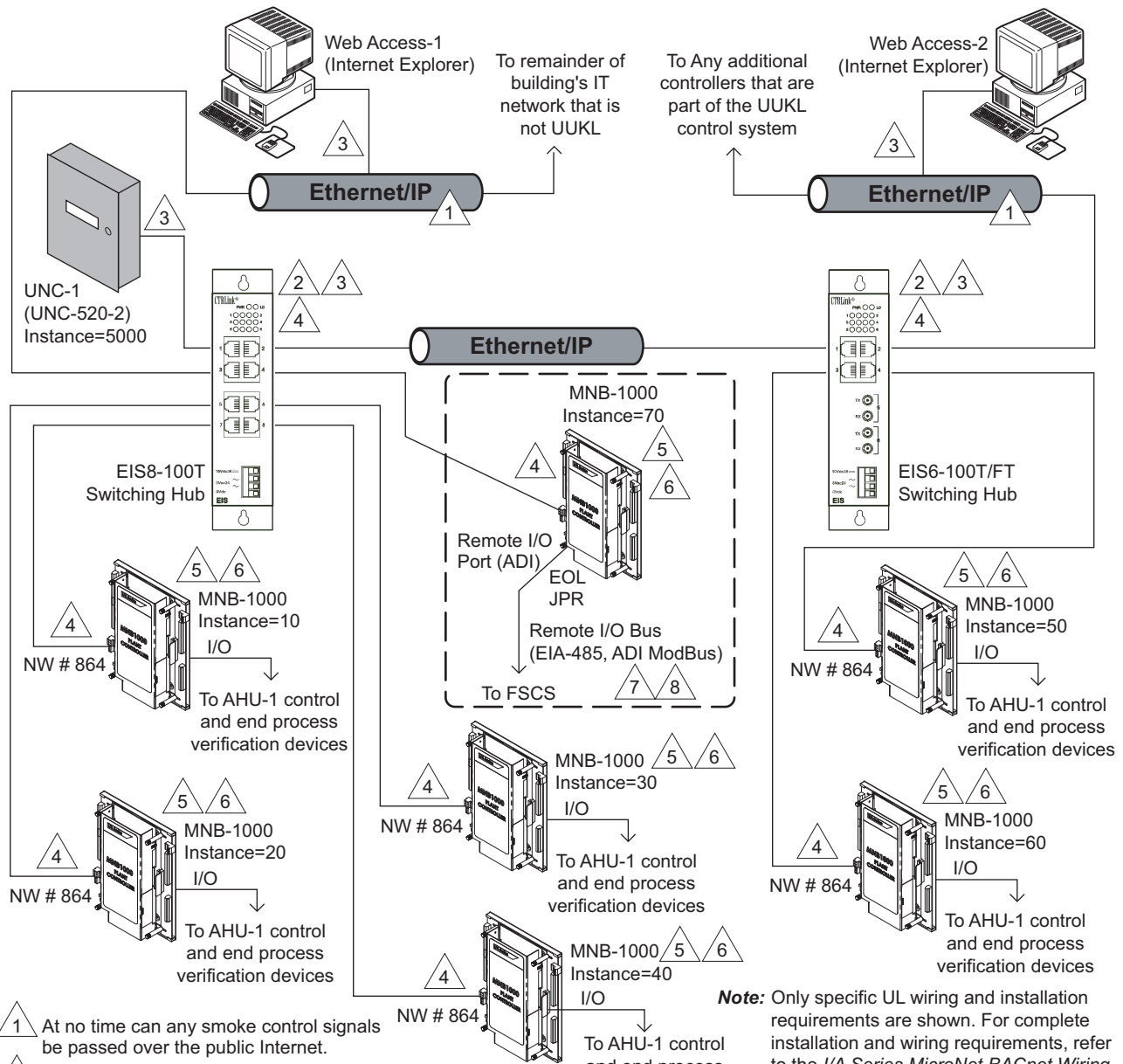

- 1 At no time can any smoke control signals be passed over the public Internet.
- 2 The UL 864 Ethernet switches shown must be installed in UL-50 enclosures.
- 3 The UL 864 Listed Ethernet switches can be used to provide isolation of non-UUKL devices from the UUKL Ethernet network. Refer to Chapter 5, "Restrictions and General Comments," for additional information regarding the use of Ethernet/IP networks and approved devices.
- 4 The path through the Ethernet/IP network from any one UUKL device to another must only use UL 864 Listed Ethernet/IP infrastructure devices.
- 5 All UUKL controllers must be mounted in approved enclosures. Refer to Chapter 5, "Restrictions and General Comments," for additional information.
- 6 See "Wiring Requirements" in this chapter.
- 7 The ADI ModBus interface to the ADI FSCS uses the Remote I/O Bus of the MNB-1000, not the MSTP Bus.
- 8 Remote I/O Bus wiring must adhere to the installation requirements defined in Chapter 5, "Restrictions and General Comments".

**Key**

EOL JPR	End-of-line resistor and/or bias resistors are engaged through on-board jumpers.
Remote I/O	Inputs and outputs remotely provided by the ADI ModBus interface. The Remote I/O Port refers to the top EIA-485 port on the MNB-1000.
I/O	Discrete input and output wiring to or from controlled or monitored devices.
NW	Network

Figure-3.2 Ethernet/IP Network Topology.

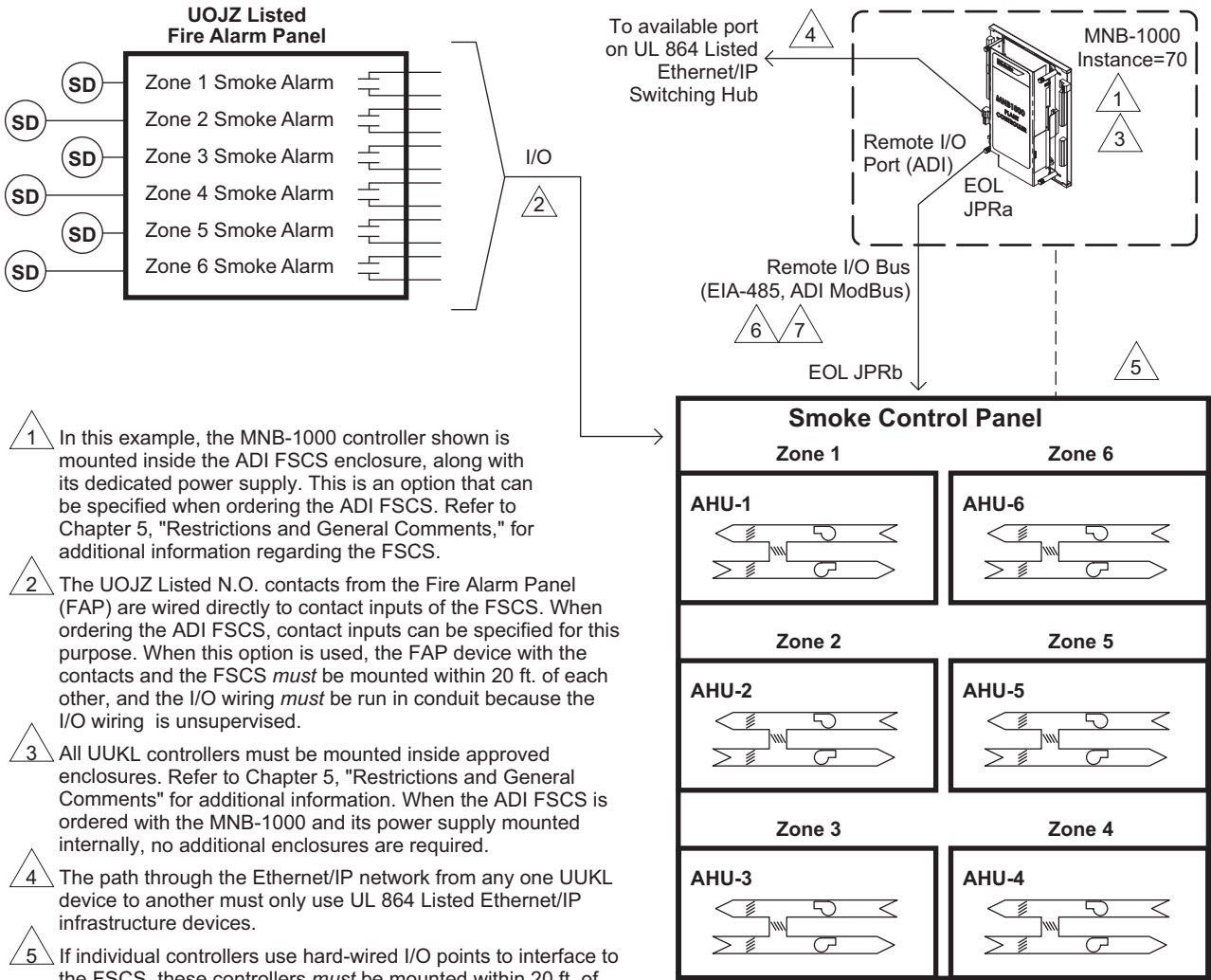

- 1 In this example, the MNB-1000 controller shown is mounted inside the ADI FSCS enclosure, along with its dedicated power supply. This is an option that can be specified when ordering the ADI FSCS. Refer to Chapter 5, "Restrictions and General Comments," for additional information regarding the FSCS.
- 2 The UOJZ Listed N.O. contacts from the Fire Alarm Panel (FAP) are wired directly to contact inputs of the FSCS. When ordering the ADI FSCS, contact inputs can be specified for this purpose. When this option is used, the FAP device with the contacts and the FSCS *must* be mounted within 20 ft. of each other, and the I/O wiring *must* be run in conduit because the I/O wiring is unsupervised.
- 3 All UUKL controllers must be mounted inside approved enclosures. Refer to Chapter 5, "Restrictions and General Comments" for additional information. When the ADI FSCS is ordered with the MNB-1000 and its power supply mounted internally, no additional enclosures are required.
- 4 The path through the Ethernet/IP network from any one UUKL device to another must only use UL 864 Listed Ethernet/IP infrastructure devices.
- 5 If individual controllers use hard-wired I/O points to interface to the FSCS, these controllers *must* be mounted within 20 ft. of the FAP, and the I/O wiring *must* be run in conduit because the I/O wiring is unsupervised.
- 6 The ADI ModBus interface to the ADI FSCS uses the Remote I/O Bus of the MNB-1000, not the MSTP Bus.
- 7 Remote I/O Bus wiring must adhere to the installation requirements defined in Chapter 5, "Restrictions and General Comments".

**Note:** Only specific UL wiring and installation requirements are shown. For complete installation and wiring requirements, refer to the *I/A Series MicroNet BACnet Wiring and Networking Practices Guide, F-27360*, and other appropriate documentation listed in Appendix C.

**Key**

EOL JPRa End-of-line resistor is engaged through an on-board jumper on the MNB-1000. Refer to the *MicroNet BACnet MNB-1000 Plant Controller Installation Instructions, F-27347*, for additional information.

EOL JPRb End-of-line resistor is engaged through an on-board jumper on the ADI FSCS. Refer to the documentation shipped with the unit.

Remote I/O Inputs and outputs remotely provided by the ADI ModBus interface. The Remote I/O Port refers to the top EIA-485 port on the MNB-1000.

I/O Discrete input and output wiring to or from controlled or monitored devices.

Figure–3.3 FSCS Interface, UOJZ Fire Alarm Panel Interface, and Related MNB-1000 Controller.

## Comments

Always refer to the NFPA 92A, NFPA 92B, NFPA 72, and UL 864 UUKL/UUKL7 standards for additional Smoke-Control Systems information. Additionally, general system application comments and restrictions are provided in Chapter 5, [Restrictions and General Comments](#) and should be thoroughly reviewed to ensure compliance with the UL listing. It is the responsibility of the field office to work with the smoke-control system designer and gain the smoke-control system approval from the Authority Having Jurisdiction (AHJ).

---

# Chapter 4

## Campus Smoke Control

### Purpose

This application provides guidelines for using I/A Series MicroNet BACnet controllers on a large campus that requires the UL 864 UUKL/UUKL7 listing for Smoke-Control Systems. This application uses MNB-300, MNB-Vx, and MNB-1000 controllers that perform the HVAC functions when in normal control mode. When in the smoke-control mode, they perform the required smoke-control sequences by controlling the individual terminal boxes, dedicated smoke-control dampers, and central air handling unit (AHU) fans. Additionally, they control all supply, exhaust, and return air dampers, and provide the feedback of all required end-process verification. The I/A Series BACnet controllers monitor N.O. relay contacts of a UOJZ Listed fire alarm panel for automatic activation of the smoke-control sequences, and monitor UUKL Listed Firefighter's Smoke Control Stations (FSCS) for manual activations and overrides. This example uses multiple ADI FSCSs that support the ADI ModBus interface to their respective MNB-1000 controllers. Each interface provides control of all of the FSCS's visual and audible status indicators, as well as receipt of the FSCS's override commands, eliminating the need to allocate numerous additional controllers to interface to the FSCS through individual I/O points.

### Sequence of Operation

#### Normal HVAC Control

---

**Note:** This application example assumes that each of the campus buildings are identical, therefore, the control equipment and sequences are the same for each building.

---

Under normal conditions, the central AHU for each building follows an occupied schedule that determines when the AHU operates. During the unoccupied mode, the outdoor and exhaust air dampers are in the full-closed position. The return air damper is in the full-open position. The supply and return fans are commanded OFF. During the occupied mode, the supply and return fans are commanded ON and the outdoor, exhaust, and return air dampers modulate as required to maintain a mixed air temperature setpoint. The central AHU can have a wide variety of additional control sequences that determine its operation and establish its operating priorities (for example, low limit stats and minimum outdoor air).

Each supply damper in a room consists of a terminal box controlled by an MNB-V2 and a dedicated motor-driven damper controlled by a digital output (DO) point from the same MNB-V2. The dedicated supply air damper remains in the full-open position at all times, unless commanded otherwise as a result of a smoke-control related condition. During normal, occupied mode conditions, the terminal box supply dampers maintain their respective zone temperature setpoints by modulating the primary air dampers and the hot water reheat. During the unoccupied mode, the terminal boxes either maintain their unoccupied zone temperature setpoints or drive to a fixed position.

---

**Note:** UL's acceptance of the MNB-V1 and MNB-V2 controllers for UUKL is based on the assumption that negative pressurization of a smoke zone is considered accomplished when the total CFM flow supplied to the zone drops below 50% of its maximum with its dedicated exhaust damper fully open. If the damper's response time is acceptable (less than 75 seconds) under this condition, and proper pressurization is achieved, dedicated supply air dampers are not necessary solely to meet response time requirements. In all cases, exhaust and supply air dampers should continue to be driven to their full-open and full-closed positions. The smoke-control system's design and its associated specification will dictate whether additional requirements apply to the supply air dampers.

---

The exhaust air dampers associated with each room (smoke-control zone) are considered dedicated smoke-control systems. These dampers are always in the full-open position unless commanded otherwise due to a smoke-control situation. The dampers are controlled by digital output (DO) points from the MNB-V2 controllers in their respective zones.

The Fire Alarm Panel (i.e. Listed Fire Alarm Control Unit) is the primary indicator for fire alarm and smoke detector conditions. It is also the primary initiator of the automatic smoke or fire alarm sequence. Upon detection of smoke and/or fire, a set of contacts in the Fire Alarm Panel (for the zone affected) close, indicating to the building automation system that a smoke or fire condition exists. In this application, a smoke detector is provided for each room (smoke-control zone). The contacts from the Fire Alarm Panel for the associated smoke detectors are monitored by the FSCS's MNB-1000 controllers. A single fire alarm panel may be located in a central building that handles all the remote buildings, or a separate fire alarm panel can be located in each protected building. The application of the panels is dependent upon the UL listings and NFPA 72 codes for which the panels are approved. In this application, a separate Fire Alarm Panel is located in each building. Check with the fire alarm panel's manufacturer to determine which listings and approvals apply to the specific models. For additional information, refer to the applicable UL and NFPA 72 codes.

---

**Note:** Any UOJZ Listed fire alarm panel with programmable N.O. relay contacts can be used with I/A Series BACnet controllers.

---

The ADI Firefighter's Smoke Control Station (i.e. Listed Smoke Control Panel) is the primary indicator for the status of all smoke control and related HVAC equipment. It also provides the interface for manual activation commands and overrides for all smoke-control related equipment. An MNB-1000 controller is mounted internal to the FSCS and provides the ADI



ModBus (control) interface to the FSCS. All commands issued from the FSCS are monitored and distributed throughout the network as required to implement the manual smoke-control sequences and overrides. The status of all of the smoke-control systems and equipment, as well as HVAC monitored trouble signals, are returned to the FSCS for visual indication, and in some cases, audible annunciation. Each MNB-1000 on an FSCS will be the central coordinator of all smoke-control activity for its respective building.

---

**Note:** Any UUKL Listed FSCS can be used with I/A Series BACnet controllers, but only the unit from Automation Displays, Inc. supports the ADI ModBus interface. When an FSCS from other vendors is used, many additional controllers will be required to provide the individual I/O point interfaces.

---

During normal operating conditions, the nondedicated smoke-control equipment does not require an automatic self-test since this equipment consists of HVAC components that are operated on a regular basis. The normal “comfort” level associated with the operability or inoperability of the equipment is considered an acceptable means of maintaining system integrity.

Dedicated smoke-control equipment, however, is used only when a smoke-control situation occurs, therefore an automatic weekly self-test of each dedicated smoke-control function is required. In this application, fan operation is verified using differential pressure sensors. The MNB-V2 damper position is verified by monitoring the cubic feet per minute (CFM) flow from the terminal box and/or its integral damper position feedback. Damper end switches are used to verify the end stroke of all dedicated supply and exhaust motor-driven dampers. All end process verifications of the dedicated zone dampers are monitored by UI points on the MNB-V2 controller associated with each zone. If a valid proof of each function occurs, no annunciation needs to take place. Otherwise, if the expected proof sensor does not operate as required, an audible trouble signal is generated and an LED is illuminated at the FSCS indicating the specific device that did not operate.

## Smoke Control Sequences

In this application, zoned smoke-control systems are used to implement the smoke-control strategies. Both dedicated and nondedicated smoke-control equipment are utilized as part of the zoned smoke-control systems.

Zoned smoke control divides a building into a number of zones for the purpose of inhibiting smoke movement.<sup>84</sup> The zones are separated from each other by smoke barriers. In the event of a fire, pressure differences and airflows produced by mechanical fans and operating dampers limit the smoke to the zone in which the fire originated.<sup>85</sup>

In this application, each room on each floor of a building is considered a smoke-control zone. When smoke is detected in any zone, all of the nonsmoke zones that are contiguous to the smoke zone, and optionally, all

---

84. National Fire Protection Association, Inc., NFPA 92A, *Standard for Smoke-Control Systems Utilizing Barriers and Pressure Differences*, NFPA 92A, 2009 ed., chap. 5, para. 5.5.1.1.

85. NFPA 92A, 2009 ed., annex A, para. A.5.5.

nonsmoke zones in the building,<sup>86</sup> are positively pressurized and the smoke is exhausted from the smoke zone. Pressurization of the noncontiguous (optional) smoke-control zones is dependent upon the smoke-control system design and its associated specification. Regardless of whether or not the noncontiguous smoke-control zones are positively pressurized, sufficient differential pressure must be achieved to limit smoke spread to the zone in which the fire originated.

---

**Note:** It is assumed that the smoke-control systems designer has considered all internal perimeters of the smoke-control zones such as corridors, restrooms, and closets. These internal perimeters require adequate pressurization that may not be achievable without supplementary fans or other mechanical equipment.

---

Anytime a smoke/fire detector trips, an automatic smoke-control sequence is initiated. For example, if the smoke/fire detector for Zone 6 of a building trips first, the automatic smoke-control sequence is initiated in the following manner.

1. The central AHU supply and return fans are commanded ON, the return air damper is driven to the full-closed position and the outdoor air and exhaust air dampers are driven to their full-open positions. This allows maximum outdoor air to be delivered to the nonsmoke zones. It also allows maximum exhausted air to be expelled from the zone reporting the smoke condition.
2. The dedicated exhaust air dampers for Zones 1, 2, 3, 5, 7, 9, 10, and 11 (zones contiguous to the smoke zone) are driven to the full-closed position while the exhaust air damper for Zone 6 (smoke zone) is driven to the full-open position. Optionally, the dedicated exhaust air dampers for the noncontiguous smoke-control zones may also be driven to the full-closed position.
3. The terminal box supply air damper and its associated dedicated supply damper for Zone 6 are driven to the full-closed position. This causes the smoke zone to become negatively pressurized.

---

**Note:** The UL acceptance of the MNB-V1 and MNB-V2 controllers for UUKL is based on the assumption that negative pressurization of a smoke zone is considered accomplished when the total CFM flow supplied to the zone drops below 50% of its maximum with its dedicated exhaust damper fully open. Sufficient differential pressure must be achieved to ensure smoke spread is confined to the zone in which the fire originated. In all cases, exhaust and supply air dampers should continue to be driven to their full-open and full-closed positions.

---

4. The terminal box supply air dampers and their associated dedicated supply dampers for Zones 1, 2, 3, 5, 7, 9, 10, and 11 (zones contiguous to the smoke zone) modulate open. The CFM flow supplied to these zones causes them to be positively pressurized. The terminal box supply dampers continue to modulate open until they reach the full-open position. Optionally, the terminal box supply air dampers for the noncontiguous smoke-control zones may also modulate open until their respective zones are positively pressurized.

---

86.NFPA 92A, 2009 ed., annex A, para. A.5.5.1.1.1.

---

**Note:** The UL acceptance of the MNB-V1 and MNB-V2 controllers for UUKL is based on the assumption that negative pressurization of a smoke zone is considered accomplished when the total CFM flow supplied to the zone drops below 50% of its maximum with its dedicated exhaust damper fully open. Sufficient differential pressure must be achieved to ensure smoke spread is confined to the zone in which the fire originated. In all cases, exhaust and supply air dampers should continue to be driven to their full-open and full-closed positions.

---

5. The automatic smoke-control sequence takes priority over the normal HVAC control sequences and any HVAC control overrides. Static pressure high limits and duct smoke detectors on supply air systems should not be automatically overridden.<sup>87</sup>
6. Once the automatic activation has occurred, subsequent alarm signals that would normally initiate an automatic smoke-control sequence will annunciate only. (For example if, in addition to the Zone 6 smoke/fire detector, the Zone 10 detector also trips, no change to the smoke-control sequence occurs and the Zone 10 smoke condition also annunciates at the FSCS.)
7. At any time, the FSCS is capable of overriding either partially, or in full, any automatic activation of a smoke-control sequence that may be in process.<sup>88</sup>
8. The communications between all of the I/A Series BACnet controllers that are part of the smoke-control sequences must be monitored. If the communications between any of these controllers fails at any time, the system trouble LED at the FSCS must illuminate and an audible signal must be generated.<sup>89</sup>
9. If any of the smoke-control equipment proof sensors fail to operate within a specified period of time during the smoke-control sequence or when under control of the FSCS, the system trouble LED at the FSCS illuminates and an audible signal is generated. If the failed smoke-control equipment is dedicated, its associated trouble LED also illuminates.

Alternately, if the smoke/fire detector for Zone 10 trips first, the automatic smoke-control sequence is initiated in the following manner.

1. The central AHU supply and return fans are commanded ON, the return air damper is driven to the full-closed position and the outdoor air and exhaust air dampers are driven to their full-open positions. This allows maximum outdoor air to be delivered to the nonsmoke zones. It also allows maximum exhausted air to be expelled from the zone reporting the smoke condition.
2. The dedicated exhaust air dampers for Zones 5, 6, 7, 9, and 11 (zones contiguous to the smoke zone) are driven to the full-closed position while the exhaust air damper for Zone 10 (smoke zone) is driven to the full-open position. Optionally, the dedicated exhaust air dampers for the noncontiguous smoke-control zones may also be driven to the full-closed position.

---

87.NFPA 92A, 2009 ed., chap. 6, para's 6.4.2 and 6.4.5.2.1.2.

88.NFPA 92A, 2009 ed., chap. 6, para 6.4.3.7.11.

89.Underwriters Laboratories Inc., UL 864, *Control Units and Accessories for Fire Alarm Systems*, 9th ed. (2003), para's 48.5, 49.4, 49.6, and 49.7.

3. The terminal box supply air damper and its associated dedicated supply damper for Zone 10 are driven to the full-closed position. This causes the smoke zone to become negatively pressurized.

---

**Note:** The UL acceptance of the MNB-V1 and MNB-V2 controllers for UUKL is based on the assumption that negative pressurization of a smoke zone is considered accomplished when the total CFM flow supplied to the zone drops below 50% of its maximum with its dedicated exhaust damper fully open. Sufficient differential pressure must be achieved to ensure smoke spread is confined to the zone in which the fire originated. In all cases, exhaust and supply air dampers should continue to be driven to their full-open and full-closed positions.

---

4. The terminal box supply air dampers and their associated dedicated supply dampers for Zones 5, 6, 7, 9, and 11 (zones contiguous to the smoke zone) modulate open. The CFM flow supplied to these zones causes them to be positively pressurized. The terminal box supply dampers continue to modulate open until they reach the full-open position. Optionally, the terminal box supply air dampers for the noncontiguous smoke-control zones may also modulate open until their respective zones are positively pressurized.

---

**Note:** The UL acceptance of the MNB-V1 and MNB-V2 controllers for UUKL is based on the assumption that negative pressurization of a smoke zone is considered accomplished when the total CFM flow supplied to the zone drops below 50% of its maximum with its dedicated exhaust damper fully open. Sufficient differential pressure must be achieved to ensure smoke spread is confined to the zone in which the fire originated. In all cases, exhaust and supply air dampers should continue to be driven to their full-open and full-closed positions.

---

5. The automatic smoke-control sequence takes priority over the normal HVAC control sequences and any HVAC control overrides. Static pressure high limits and duct smoke detectors on supply air systems should not be automatically overridden.<sup>90</sup>
6. Once automatic activation has occurred, subsequent alarm signals that would normally initiate an automatic smoke-control sequence will annunciate only. (For example if, in addition to the Zone 10 smoke/fire detector, the Zone 7 detector also trips, no change to the smoke-control sequence occurs and the Zone 7 smoke condition also annunciates at the FSCS.)
7. At any time, the FSCS is capable of overriding either partially, or in full, any automatic activation of a smoke-control sequence that may be in process.<sup>91</sup>
8. The communications between all of the I/A Series BACnet controllers that are part of the smoke-control sequences must be monitored. If the communications between any of these controllers fails at any time, the system trouble LED at the FSCS must illuminate and an audible signal must be generated.<sup>92</sup>

---

90.NFPA 92A, 2009 ed., chap. 6, para's 6.4.2 and 6.4.5.2.1.2.

91.NFPA 92A, 2009 ed., chap. 6, para 6.4.3.7.11.

92.UL 864, 9th ed., para's 48.5, 49.4, 49.6, and 49.7.

9. If any of the smoke-control equipment proof sensors fail to operate within a specified period of time during the smoke-control sequence or when under control of the FSCS, the system trouble LED at the FSCS illuminates and an audible signal generates. If the failed smoke-control equipment is dedicated, its associated trouble LED also illuminates.

## Smoke-Control System Configuration Schedule

Each smoke-control system configuration should be defined in a schedule.<sup>93</sup> The schedule should list all dedicated and nondedicated smoke-control equipment and show the equipment response for each sensor that activates an automatic smoke-control sequence. An example schedule for this application is shown below (Table-4.1).

(Opn = Open, Clsd = Closed, "+" = Pos. Press., "-" = Neg. Press.  
F.O. = Full Open, F.C. = Full Closed, Terminal Box = VAV Box)

---

**Note:**

- According to NFPA 92A, only the smoke zones that are contiguous to the zone reporting the smoke condition have to be positively pressurized. For this application, all non-smoke zones are being positively pressurized.
  - Pressurization of the noncontiguous (optional) smoke-control zones is dependent upon the smoke-control system design and its associated specification. Regardless of whether or not noncontiguous smoke-control zones are positively pressurized, sufficient differential pressure must be achieved to ensure smoke spread is confined to the zone in which the fire originated.
- 

---

93.NFPA 92A, 2009 ed., chap. 6, para 6.4.5.3 and annex A, para A.6.4.5.3.

## Chapter 4

**Table-4.1 Schedule for Smoke-Control System Configuration .**

Dedicated and Nondedicated Smoke Control Equipment	Smoke Detector Zones In Alarm											
	1	2	3	4	5	6	7	8	9	10	11	12
AHU Supply Fan	ON	ON	ON	ON	ON	ON	ON	ON	ON	ON	ON	ON
AHU Return Fan	OFF	OFF	OFF	OFF	OFF	OFF	OFF	OFF	OFF	OFF	OFF	OFF
AHU O.A. Damper	F.O.	F.O.	F.O.	F.O.	F.O.	F.O.	F.O.	F.O.	F.O.	F.O.	F.O.	F.O.
AHU Return Damper	F.C.	F.C.	F.C.	F.C.	F.C.	F.C.	F.C.	F.C.	F.C.	F.C.	F.C.	F.C.
AHU Exhaust Damper	F.C.	F.C.	F.C.	F.C.	F.C.	F.C.	F.C.	F.C.	F.C.	F.C.	F.C.	F.C.
Zone 1 Exhaust Damper	Opn	Clsd	Clsd	Clsd	Clsd	Clsd	Clsd	Clsd	Clsd	Clsd	Clsd	Clsd
Zone 1 Supply Damper	Clsd	Opn	Opn	Opn	Opn	Opn	Opn	Opn	Opn	Opn	Opn	Opn
Zone 1 VAV Box Supply	Clsd	Opn	Opn	Opn	Opn	Opn	Opn	Opn	Opn	Opn	Opn	Opn
Zone 1	-	+	+	+	+	+	+	+	+	+	+	+
Zone 2 Exhaust Damper	Clsd	Opn	Clsd	Clsd	Clsd	Clsd	Clsd	Clsd	Clsd	Clsd	Clsd	Clsd
Zone 2 Supply Damper	Opn	Clsd	Opn	Opn	Opn	Opn	Opn	Opn	Opn	Opn	Opn	Opn
Zone 2 VAV Box Supply	Opn	Clsd	Opn	Opn	Opn	Opn	Opn	Opn	Opn	Opn	Opn	Opn
Zone 2	+	-	+	+	+	+	+	+	+	+	+	+
Zone 3 Exhaust Damper	Clsd	Clsd	Opn	Clsd	Clsd	Clsd	Clsd	Clsd	Clsd	Clsd	Clsd	Clsd
Zone 3 Supply Damper	Opn	Opn	Clsd	Opn	Opn	Opn	Opn	Opn	Opn	Opn	Opn	Opn
Zone 3 VAV Box Supply	Opn	Opn	Clsd	Opn	Opn	Opn	Opn	Opn	Opn	Opn	Opn	Opn
Zone 3	+	+	-	+	+	+	+	+	+	+	+	+
Zone 4 Exhaust Damper	Clsd	Clsd	Clsd	Opn	Clsd	Clsd	Clsd	Clsd	Clsd	Clsd	Clsd	Clsd
Zone 4 Supply Damper	Opn	Opn	Opn	Clsd	Opn	Opn	Opn	Opn	Opn	Opn	Opn	Opn
Zone 4 VAV Box Supply	Opn	Opn	Opn	Clsd	Opn	Opn	Opn	Opn	Opn	Opn	Opn	Opn
Zone 4	+	+	+	-	+	+	+	+	+	+	+	+
Zone 5 Exhaust Damper	Clsd	Clsd	Clsd	Clsd	Opn	Clsd	Clsd	Clsd	Clsd	Clsd	Clsd	Clsd
Zone 5 Supply Damper	Opn	Opn	Opn	Opn	Clsd	Opn	Opn	Opn	Opn	Opn	Opn	Opn
Zone 5 VAV Box Supply	Opn	Opn	Opn	Opn	Clsd	Opn	Opn	Opn	Opn	Opn	Opn	Opn
Zone 5	+	+	+	+	-	+	+	+	+	+	+	+
Zone 6 Exhaust Damper	Clsd	Clsd	Clsd	Clsd	Clsd	Opn	Clsd	Clsd	Clsd	Clsd	Clsd	Clsd
Zone 6 Supply Damper	Opn	Opn	Opn	Opn	Opn	Clsd	Opn	Opn	Opn	Opn	Opn	Opn
Zone 6 VAV Box Supply	Opn	Opn	Opn	Opn	Opn	Clsd	Opn	Opn	Opn	Opn	Opn	Opn
Zone 6	+	+	+	+	+	-	+	+	+	+	+	+
Zone 7 Exhaust Damper	Clsd	Clsd	Clsd	Clsd	Clsd	Clsd	Opn	Clsd	Clsd	Clsd	Clsd	Clsd
Zone 7 Supply Damper	Opn	Opn	Opn	Opn	Opn	Opn	Clsd	Opn	Opn	Opn	Opn	Opn
Zone 7 VAV Box Supply	Opn	Opn	Opn	Opn	Opn	Opn	Clsd	Opn	Opn	Opn	Opn	Opn
Zone 7	+	+	+	+	+	+	-	+	+	+	+	+
Zone 8 Exhaust Damper	Clsd	Clsd	Clsd	Clsd	Clsd	Clsd	Clsd	Opn	Clsd	Clsd	Clsd	Clsd
Zone 8 Supply Damper	Opn	Opn	Opn	Opn	Opn	Opn	Opn	Clsd	Opn	Opn	Opn	Opn
Zone 8 VAV Box Supply	Opn	Opn	Opn	Opn	Opn	Opn	Opn	Clsd	Opn	Opn	Opn	Opn
Zone 8	+	+	+	+	+	+	+	-	+	+	+	+
Zone 9 Exhaust Damper	Clsd	Clsd	Clsd	Clsd	Clsd	Clsd	Clsd	Clsd	Opn	Clsd	Clsd	Clsd
Zone 9 Supply Damper	Opn	Opn	Opn	Opn	Opn	Opn	Opn	Opn	Clsd	Opn	Opn	Opn
Zone 9 VAV Box Supply	Opn	Opn	Opn	Opn	Opn	Opn	Opn	Opn	Clsd	Opn	Opn	Opn
Zone 9	+	+	+	+	+	+	+	+	-	+	+	+
Zone 10 Exhaust Damper	Clsd	Clsd	Clsd	Clsd	Clsd	Clsd	Clsd	Clsd	Clsd	Opn	Clsd	Clsd
Zone 10 Supply Damper	Opn	Opn	Opn	Opn	Opn	Opn	Opn	Opn	Opn	Clsd	Opn	Opn
Zone 10 VAV Box Supply	Opn	Opn	Opn	Opn	Opn	Opn	Opn	Opn	Opn	Clsd	Opn	Opn
Zone 10	+	+	+	+	+	+	+	+	+	-	+	+
Zone 11 Exhaust Damper	Clsd	Clsd	Clsd	Clsd	Clsd	Clsd	Clsd	Clsd	Clsd	Clsd	Opn	Clsd
Zone 11 Supply Damper	Opn	Opn	Opn	Opn	Opn	Opn	Opn	Opn	Opn	Opn	Clsd	Opn
Zone 11 VAV Box Supply	Opn	Opn	Opn	Opn	Opn	Opn	Opn	Opn	Opn	Opn	Clsd	Opn
Zone 11	+	+	+	+	+	+	+	+	+	+	-	+
Zone 12 Exhaust Damper	Clsd	Clsd	Clsd	Clsd	Clsd	Clsd	Clsd	Clsd	Clsd	Clsd	Clsd	Opn
Zone 12 Supply Damper	Opn	Opn	Opn	Opn	Opn	Opn	Opn	Opn	Opn	Opn	Opn	Clsd
Zone 12 VAV Box Supply	Opn	Opn	Opn	Opn	Opn	Opn	Opn	Opn	Opn	Opn	Opn	Clsd
Zone 12	+	+	+	+	+	+	+	+	+	+	+	-

## Firefighter's Smoke Control Station (FSCS)

The requirements of the FSCS are similar to the ones shown in Chapter 2. The graphic depiction and smoke-control equipment used changes based on the sequence of operation for this application.

### System Topologies

#### Campus Topology with MNB-1000 Controllers

The MNB-1000 (Instance 100) controller provides the central AHU control, monitors end process verification devices, distributes and receives global information between controllers in the network, monitors communications to all of the controllers beneath it, and initiates smoke-control sequences based on information received from the appropriate controllers (Figure—4.1). Its MS/TP communication trunk connects to the MNB-Vx controllers that provide HVAC control of the occupied spaces. These MNB-Vx controllers also control the dedicated supply and exhaust air smoke dampers to each smoke-control zone; and monitor the proof-of-position switches for the dedicated dampers.

The MNB-1000 (Instance 150) controller provides a complete interface to the FSCS through its EIA-485 (RS-485) ADI ModBus interface. It is mounted inside the FSCS, along with its power supply. This controller functions as the master of the smoke-control network in the building where it is installed. It monitors communications to all of the controllers that are part of the smoke-control system, distributes and receives global information between controllers in the network, and initiates smoke-control sequences based on information received from the appropriate controllers. Additionally, it's UI and DI points interface to the N.O. contacts of the UOJZ Fire Alarm Panel to monitor each zone's smoke or fire detector.

---

**Note:**

- In this example application, all seven buildings have the same basic controller requirements and topology. Therefore, the explanations describe only one building (Building 1) as a representative example.
  - To simplify the application, only a minimal number of controllers are shown for each building. The actual number required depends on the actual size and programming complexity of the job.
- 

#### Ethernet/IP Infrastructure

Any UL 864 Listed IP infrastructure devices can be used to create the network topology. Currently, the only available units are the EIS8-100T and EIS6-100T/FT switching hubs from Contemporary Controls. The path through the Ethernet/IP network from any one UUKL device to another must use only UL 864 Listed infrastructure devices. The Ethernet/IP Smoke-Control System can coexist with the non-UL 864 networks, as long as they are isolated from those networks through the use of UL 864 Listed IP infrastructure devices. Refer to Chapter 5, [Restrictions and General Comments](#), for additional information. In this example (Figure—4.1 and Figure—4.2), the fiber optic feature of the EIS6-100T/FT switching

hubs is used to connect the individual buildings, thus creating a fiber backbone. Once inside a building, the smoke-control system's infrastructure is expanded through the use of EIS8-100T switching hubs.

---

**Note:** At no time can any smoke control signals be passed over the public Internet.

---

### Wiring Requirements

Because the I/O wiring between the I/A Series BACnet controllers and the FSCS (when an I/O wiring interface is used) and the UOJZ Fire Alarm Panel is unsupervised, the I/A Series BACnet controllers used for this purpose must be mounted within 20 ft of the panel to which they are connected. The I/O wiring must be run in conduit. [Table–4.2](#), below, lists the general requirements for the wiring associated with an I/A Series BACnet smoke-control application.

**Table–4.2 Wiring Requirements.**

Wiring	Status
Ethernet/IP	Supervised by block programming
EIA-485 ADI ModBus	Supervised by block programming. When MNB-1000 is mounted external to the FSCS, wiring must be run in conduit and controller must be located within 20 ft. of the panel.
MS/TP Bus	Supervised by block programming
I/O to FSCS	Unsupervised, wiring must be run in conduit and controllers must be located within 20 ft. of the panel.
I/O to UOJZ FAP Contacts	Unsupervised, wiring must be run in conduit and controllers must be located within 20 ft. of the panel.
Remaining I/O	Unsupervised

### Central System Interface and Overlay Devices

When a UNC, Web Server, and/or other central-system type interfaces are attached to the Ethernet/IP network with the ability to access the smoke-control system, they must be isolated from the network through the use of UL 864 Listed IP infrastructure devices ([Figure–4.2](#)). This isolation is required by UL because these devices, PC's and/or interfaces, are not UL 864 Listed. Therefore these devices cannot be used for smoke-control purposes.

Refer to Chapter 5, [Restrictions and General Comments](#), for additional information.



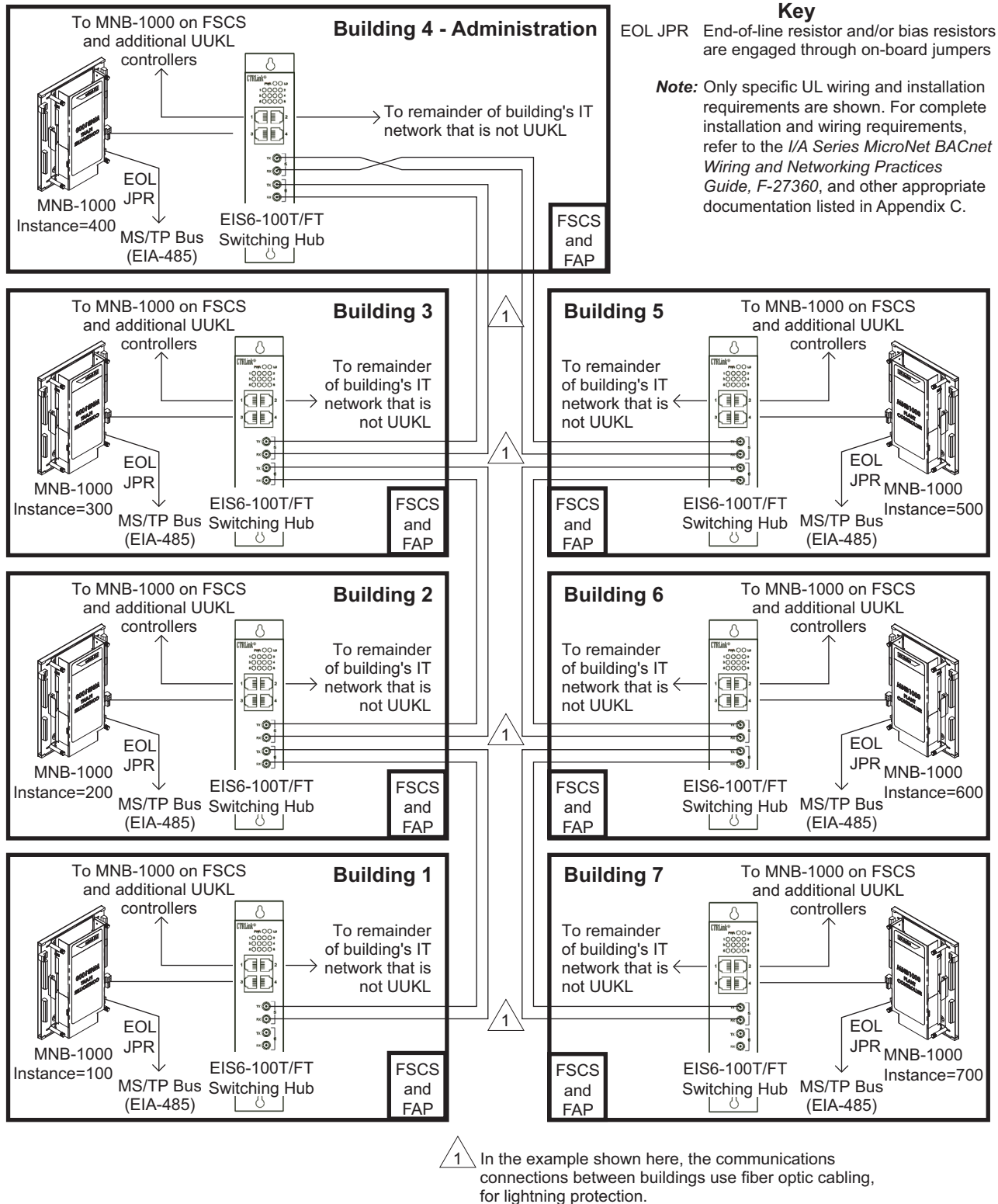

Figure-4.1 Campus Topology with MNB-1000 Controllers.

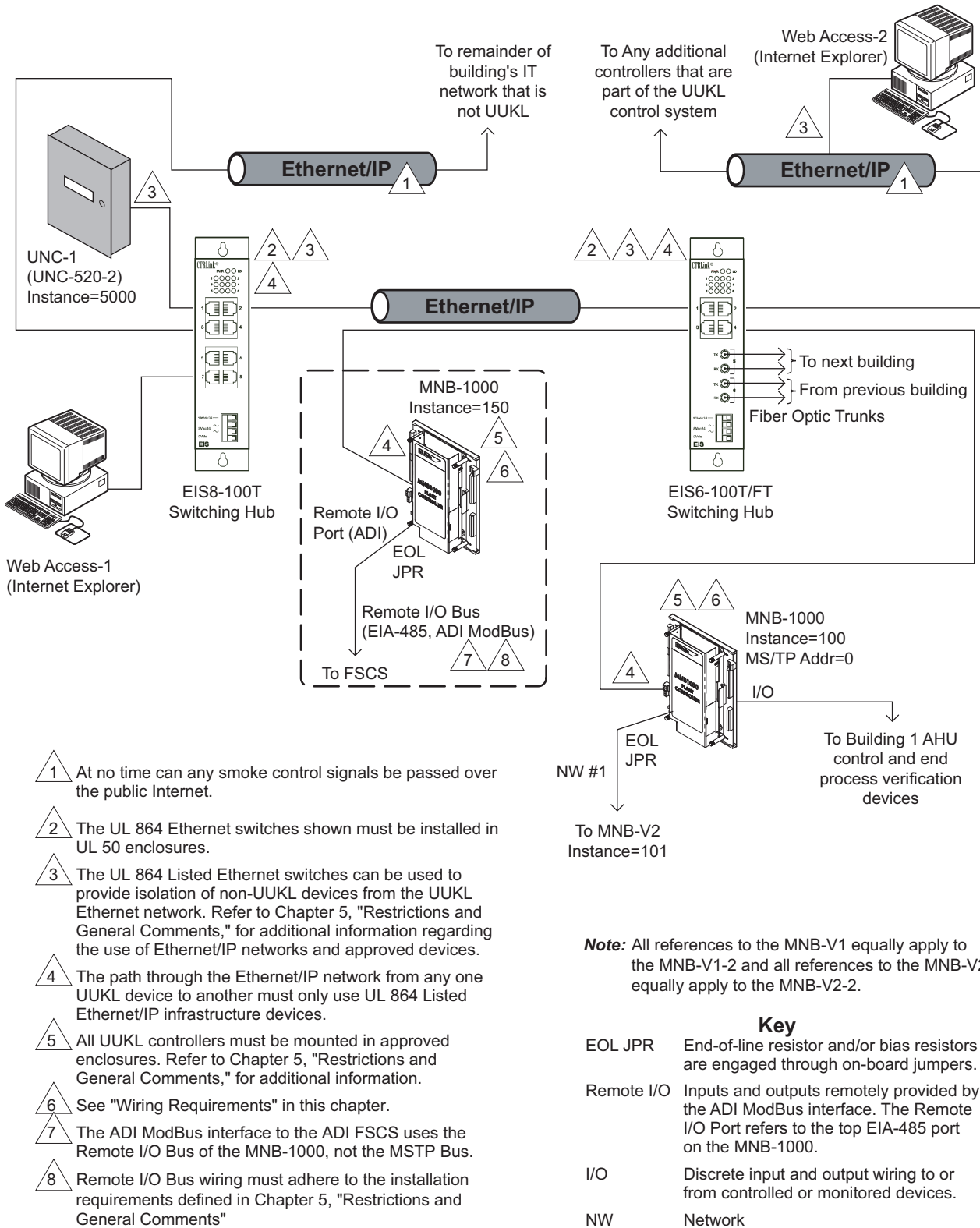

Figure 4.2 Ethernet/IP Network Topology—Typical of Each Building.

## **MNB-V2 Topology**

Each building has a central AHU that serves the entire building and is controlled by an MNB-1000. Each room has an MNB-V2 that controls the VAV terminal box (Figure—4.3). During normal occupied conditions, each MNB-V2 modulates its primary damper and the hot water reheat, as required, to maintain its zone temperature setpoint. During the unoccupied mode, each terminal box either maintains its respective unoccupied zone temperature setpoint or is driven to a fixed position. Each room on a floor is considered a smoke-control zone. By controlling the VAV box, the MNB-V2 controls the supply air to each zone. A dedicated exhaust damper is required for each smoke-control zone and is controlled by a spare DO point from the MNB-V2 serving its zone. The dedicated exhaust dampers are always in the full-open position unless commanded otherwise due to a smoke-control condition.

In this example, each smoke-control zone shows a dedicated supply damper that is controlled by another spare DO point from the same MNB-V2. The dedicated supply dampers remain in the full-open position at all times, unless commanded otherwise as a result of a smoke-control related condition. This building layout is typical for all the buildings on the campus.

---

**Note:** UL's acceptance of the MNB-V1 and MNB-V2 controllers for UUKL is based on the assumption that negative pressurization of a smoke zone is considered accomplished when the total CFM flow supplied to the zone drops below 50% of its maximum with its dedicated exhaust damper fully open. If the damper's response time is acceptable (less than 75 seconds) under this condition, and proper pressurization is achieved, dedicated supply air dampers are not necessary solely to meet response time requirements. In all cases, exhaust and supply air dampers should continue to be driven to their full-open and full-closed positions. The smoke-control system's design and its associated specification will dictate whether additional requirements apply to the supply air dampers.

---

Damper end switches are used to verify the end stroke of all dedicated supply and exhaust motor-driven dampers. All end process verification of the dedicated zone dampers is monitored by UI points on the MNB-V2 controller associated with each zone.

### **MS/TP Bus Requirements**

A repeater is required for the MS/TP bus whenever there is a need to extend the maximum distance of the bus or increase the number of devices that can be connected to the bus. The B-LINK-AC repeater can be used for this purpose.

Refer to Chapter 5, [Restrictions and General Comments](#) for additional repeater information.

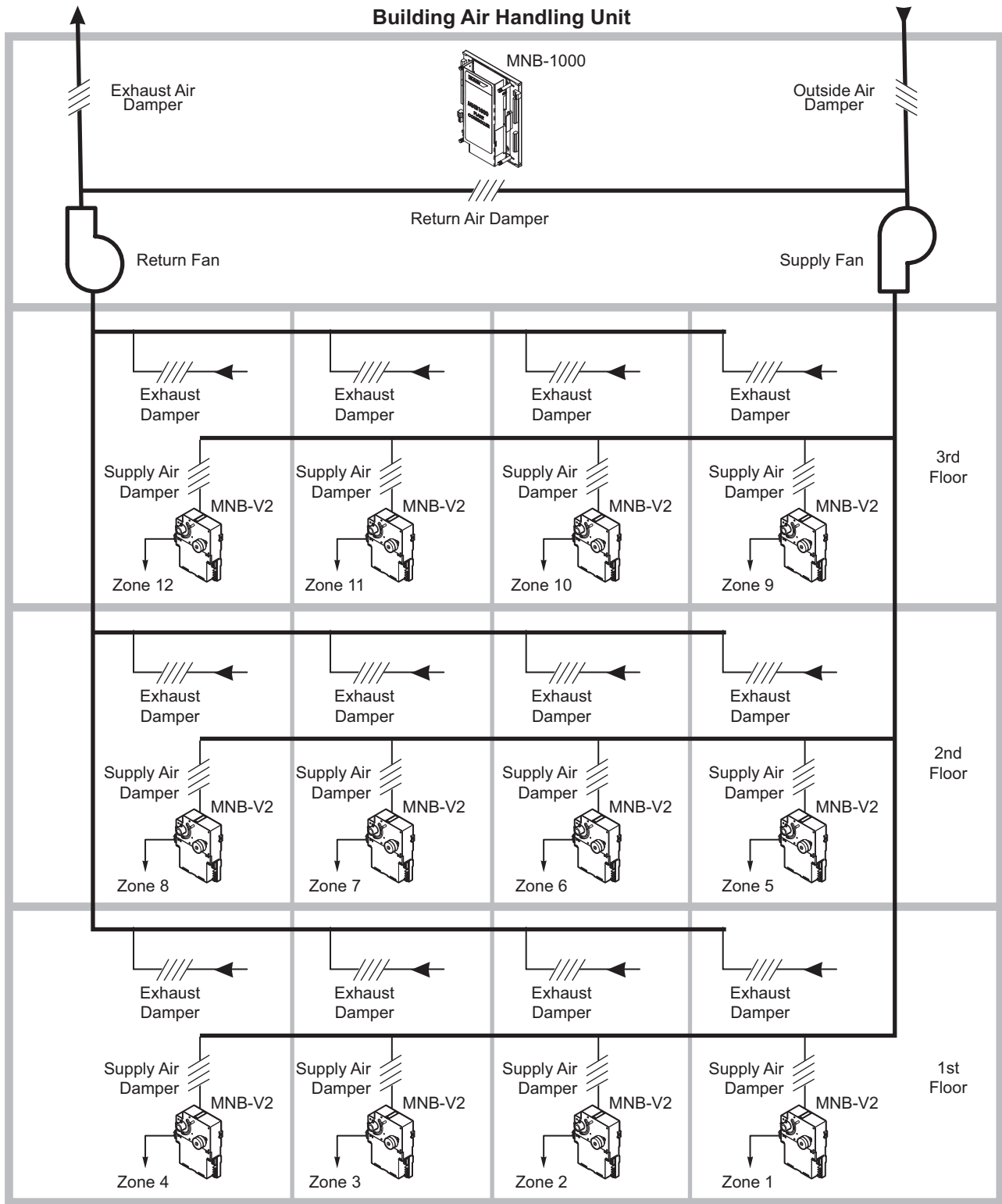

**Note:** All references to the MNB-V1 equally apply to the MNB-V1-2 and all references to the MNB-V2 equally apply to the MNB-V2-2.

Figure-4.3 Typical Building Topology.

## **MNB-1000 Interface to FSCS**

In a multi-building application such as this, a separate FSCS is typically required for each protected premises or building. The following description is typical of each building, with the only difference being the controller instance numbers.

The MNB-1000 (Instance 150) controller (Building 1) provides a complete interface to the FSCS through its EIA-485 (RS-485) ADI ModBus interface (Figure—4.4). It controls all of the FSCS LEDs and monitors all of the FSCS override switches. The FSCS (panel) Enable switch functionality is also enforced through programming in the MNB-1000 controller. Refer to Chapter 5, [Restrictions and General Comments](#) for an example of this programming and for additional information on the FSCS interface.

When interfaced to the ADI FSCS, the MNB-1000 controller and its power supply are mounted inside the FSCS enclosure, eliminating the need for separate enclosures. This controller functions as the master of the smoke-control network for the building where it is installed. One master exists in each building. It monitors communications to all of the controllers that are part of the smoke-control system, distributes and receives global information between controllers in the network, initiates smoke-control sequences based on information received from the appropriate controllers, and integrates the FSCS functionality into the system.

---

**Note:** When using I/O points to interface to a UL 864 UUKL/UUKL7 Listed FSCS in place of using an ADI FSCS that supports the ADI ModBus protocol, many additional controllers will be required. Each installation must be carefully assessed to ensure that adequate quantities of devices have been allotted to perform the necessary control and monitoring functions. Refer to "[Job Estimating](#)" on page 78 for point calculating specifics.

---

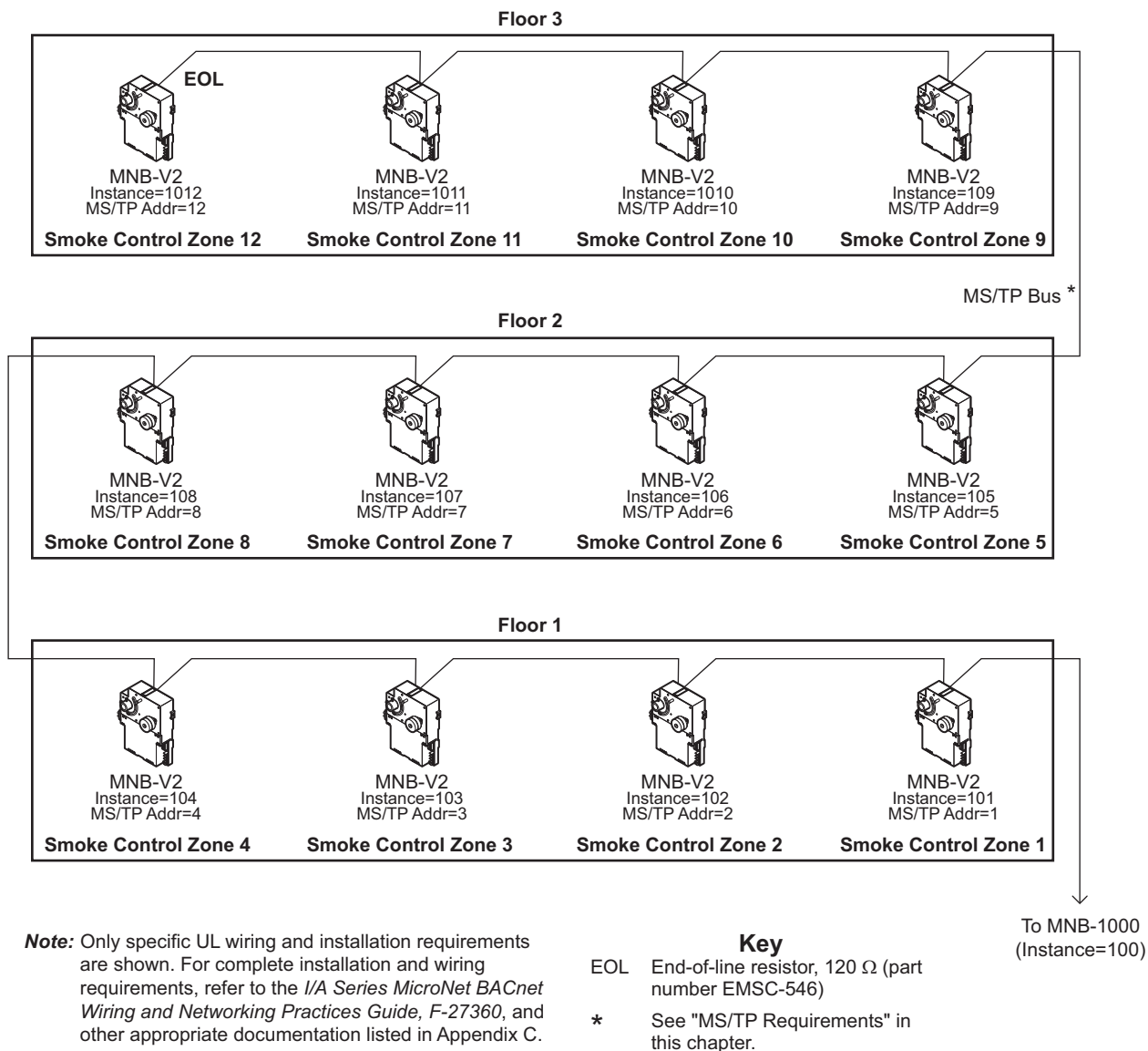

Figure-4.4 MNB-V2 Controller Topology—Typical of Each Building.

## **Fire Alarm Panel Interface**

In this application, a separate Fire Alarm Panel (FAP) is located in each building. Alternatively, a single FAP panel that handles all of the remote buildings may be located in a central building, instead. The manner in which the FAPs are applied is dependent upon the UL Listing and NFPA 72 codes for which the panels are approved. Check with the FAP manufacturer to determine which listings and approvals apply to specific models. For additional information, refer to the applicable UL and NFPA codes. The following description is typical of each building.

In Building 1, the UOJZ Listed N.O. contacts from the Fire Alarm Panel are wired directly to contact inputs of the FSCS MNB-1000 (Figure—4.5). When this option is used, the FSCS and the FAP device supplying the contacts must be mounted within 20 ft. of each other, and the I/O wiring must be run in conduit because the I/O wiring is unsupervised.

When the FAP is interfaced to the FSCS MNB-1000 in this manner, the statuses of the smoke alarms are received by the MNB-1000 (Instance 150) controller through its I/O points and distributed throughout the network, as required, to support the smoke-control sequence.

---

**Note:** When using controller I/O points to interface to UOJZ Listed N.O. contacts from a Fire Alarm Panel, several additional controllers will be required. Each installation must be carefully assessed to ensure that adequate quantities of devices have been allotted to perform the necessary control and monitoring functions. Refer to "[Job Estimating](#)" on page 78 for point calculating specifics.

---

## **Comments**

Always refer to the NFPA 92A, NFPA 72, and UL 864 UUKL/UUKL7 standards for additional Smoke-Control Systems information. Additionally, general system application comments and restrictions are provided in Chapter 5, [Restrictions and General Comments](#). This chapter should be thoroughly reviewed to ensure compliance with the UL listing. It is the responsibility of the field office to work with the smoke-control system designer and gain the smoke-control system approval from the Authority Having Jurisdiction (AHJ).

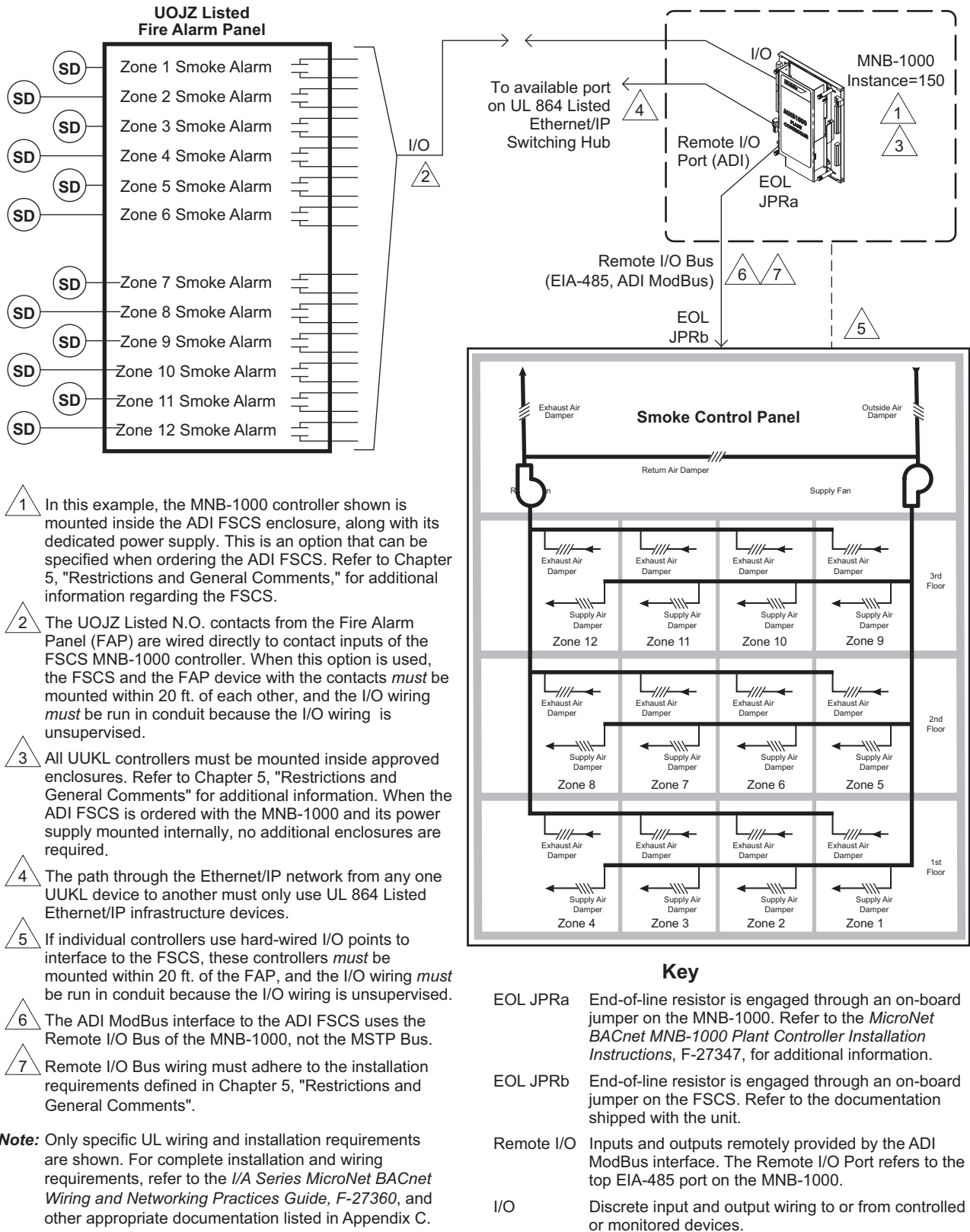

Figure-4.5 FSCS Interface—UOJZ Fire Alarm Panel Interface and Related MNB-1000 Controller.

- 1 In this example, the MNB-1000 controller shown is mounted inside the ADI FSCS enclosure, along with its dedicated power supply. This is an option that can be specified when ordering the ADI FSCS. Refer to Chapter 5, "Restrictions and General Comments," for additional information regarding the FSCS.
- 2 The UOJZ Listed N.O. contacts from the Fire Alarm Panel (FAP) are wired directly to contact inputs of the FSCS MNB-1000 controller. When this option is used, the FSCS and the FAP device with the contacts *must* be mounted within 20 ft. of each other, and the I/O wiring *must* be run in conduit because the I/O wiring is unsupervised.
- 3 All UUKL controllers must be mounted inside approved enclosures. Refer to Chapter 5, "Restrictions and General Comments" for additional information. When the ADI FSCS is ordered with the MNB-1000 and its power supply mounted internally, no additional enclosures are required.
- 4 The path through the Ethernet/IP network from any one UUKL device to another must only use UL 864 Listed Ethernet/IP infrastructure devices.
- 5 If individual controllers use hard-wired I/O points to interface to the FSCS, these controllers *must* be mounted within 20 ft. of the FAP, and the I/O wiring *must* be run in conduit because the I/O wiring is unsupervised.
- 6 The ADI ModBus interface to the ADI FSCS uses the Remote I/O Bus of the MNB-1000, not the MSTP Bus.
- 7 Remote I/O Bus wiring must adhere to the installation requirements defined in Chapter 5, "Restrictions and General Comments".

**Note:** Only specific UL wiring and installation requirements are shown. For complete installation and wiring requirements, refer to the *I/A Series MicroNet BACnet Wiring and Networking Practices Guide, F-27360*, and other appropriate documentation listed in Appendix C.



---

# Chapter 5

## Restrictions and General Comments

### Purpose

This chapter lists restrictions associated with the application of I/A Series MicroNet BACnet controllers to UL 864 UUKL/UUKL7 smoke-control systems. These restrictions take precedence over existing I/A Series BACnet literature and are required to meet the UL 864 UUKL/UUKL7 Listing. This chapter also includes general comments that may provide additional insight or flexibility during the engineering process.

### Restrictions

#### Software Access Levels

There are three primary tools used with I/A Series MicroNet BACnet controllers: Flow Balance Tool, Commissioning Tool, and WorkPlace Tech Tool (WP Tech).

##### Flow Balance Tool and Commissioning Tool

The Flow Balance Tool and Commissioning Tool use their own, built-in, dual-level security configuration. Whenever either of these tools is used on a UUKL job site, the security must be configured and enabled. The two access levels are:

**Manager Level:** Anyone with manager-level access is considered to be at the “programmer” level and not a “day-to-day operator”.

**User Level:** Anyone with user-level access is considered to be a “day-to-day operator”. Typical changes made by the “day-to-day operator” will not affect the smoke-control sequence.

For each access level, a password of at least five characters must be assigned, “Auto-lock” must be enabled, and the “Auto-lock” time period must be set at 30 minutes or less. The “Auto-lock” time period defines the period of inactivity that must pass before the tool locks access to the program. When the program is locked in this way, the user or manager must log back into the system before operation can resume.

### **WorkPlace Tech Tool**

When using or leaving WP Tech at a UUKL job site, its security feature must be configured and enabled through the Commissioning Tool. When using the security feature with WP Tech, the following apply:

- The “Auto-lock” feature is not available.
- Only the manager level of access is valid. Users are not allowed to start WP Tech.
- The “Auto-lock” feature associated with the manager level must be configured and handled by the Windows® account used by the individual.

When running WP Tech at the job site, a dedicated Windows user account must be used. To define the password protection and “Auto-lock” aspects of each user account, right-click the Windows desktop, and then use the Screen Saver tab of the Windows Desktop Properties dialog box. Each account used for this purpose must have a password of at least five characters, have "Auto-lock" enabled, and have an "Auto-lock" time period of 30 minutes or less. These accounts must not be used for any other purpose.

## **System Overrides**

### **Overrides that Require Removal**

If a person with manager-level (programmer-level) access overrides any values or functions in the I/A Series BACnet controllers, in a manner that impedes the automatic smoke-control functions or interferes with the FSCS’s absolutely highest priority control over the system, then the overrides must be removed before the system is returned to normal operation. This rule always applies, whether the purpose of the override is for troubleshooting, service, programming, or temporary control.

### **Overrides that Do Not Require Removal**

Overrides do not need to be removed before the system is returned to normal operation if they are initiated in a manner that does not impact the automatic smoke-control functions or the ability of the FSCS to have absolutely highest priority control over the system. Such overrides can be considered exceptions to the restriction described above, in [Overrides that Require Removal](#).

This exception is only applicable if all automatic smoke-control functions are commanded through the BACnet priority level of “Automatic Life Safety (2)”, and all FSCS commands are commanded through the BACnet priority level of “Manual Life Safety (1)”.

Examples of these types of overrides include those initiated by any BACnet device or tool, at a priority below the “Automatic Life Safety” level.

**Input Priority Levels:** In a BACnet input name, the numeral in brackets signifies the level of priority. For example, the input name “Manual Life Safety (1)” means that the input, “Manual Life Safety,” has the highest BACnet priority level. “Automatic Life Safety (2)” means that this input has the second-highest priority level, and so forth.

## **Approved Fire Alarm Panels**

Any UOJZ listed fire alarm panel with programmable N.O. relay contacts can be used with I/A Series BACnet controllers. The fire alarm panel (i.e. listed Fire Alarm Control Unit) is the primary indicator for smoke and fire alarm conditions. These panels are listed for the UOJZ category of the UL 864 standard. The dry contact outputs from the UOJZ listed fire alarm panel can be wired directly to the appropriate inputs of the I/A Series MicroNet BACnet controllers, or to inputs provided on the UUKL listed Firefighter's Smoke Control Station (FSCS).

## **Approved Firefighter's Smoke Control Stations**

Any UUKL listed Firefighter's Smoke Control Station (FSCS) can be used with I/A Series BACnet controllers. The FSCS (i.e. listed Smoke Control Panel) is the primary indicator for the status of all smoke control and related HVAC equipment. The FSCS also provides the interface for manual activation commands and overrides for all smoke control and related HVAC equipment. The FSCS is listed for the UUKL category of the UL 864 standard.

The Automation Displays, Inc. (ADI) series of graphic smoke-control panels are UUKL listed and can be used for smoke-control applications. They can be equipped with terminals that allow wiring to discrete I/O points, an ADI ModBus EIA-485 (RS-485) interface for controllers that support the ADI ModBus interface, or a hybrid of the two. If the ADI ModBus EIA-485 version is used with an MNB-1000 controller (which supports the ADI ModBus interface), the combination can take advantage of reduced I/O count requirements, reduced engineering and installation time, and use of the WP Tech ADI Wizard to expedite the process of FSCS and BACnet point creation in the application database.

---

### **Note: WP Tech ADI Wizard**

The ADI Wizard, used in concert with the LED/Switch definition file (generated during the FSCS specification/ordering phase), provides the following productivity advantages:

- Automatic creation of all LED and Switch objects.
- Automatic naming of all ADI point objects, in accordance with specification requirements.
- Automatic configuration of the LED and Switch (ADI ModBus) bank and register data.
- Configuration of all ADI ModBus communication-related parameters.
- Global and individual changes to the Switch output format (ON-OFF or ON-NA).
- Global and individual changes to Switch-enabled statuses for interlocking to the FSCS Enable switch.
- Drag-and-drop functionality on any page of a WP Tech application drawing.
- Unique BACnet objects are automatically created for all ADI objects.

---

When using an ADI FSCS, the I/A Series BACnet Controllers and their transformers can be mounted either inside or outside the FSCS. If the controllers and transformers are mounted internally, they can be supplied to the FSCS vendor for pre-installation and wiring. If the controllers and transformers are to be mounted externally, they must comply with the installation requirements detailed throughout this manual and in the documentation listed in Appendix C.

When ordering an ADI FSCS, it is necessary, as a minimum, to provide the vendor with the information listed below. Note that this list is provided only as a guide for organizing the process. The actual requirements must be worked out with the vendor.

- A detailed drawing of the graphic required.
- Switch quantities, types, locations, and related label text (if any).
- LED quantities, locations, colors, and related label text (if any).
- A spreadsheet listing the name (20 characters or less) of each LED and switch position point, and their related descriptions. Note that this information is also used by the ADI Wizard to expedite the point creation process in WP Tech.
- Panel size and any other requirements affecting the FSCS's physical construction.
- Supporting dimensions and wiring diagrams associated with any controllers and transformers that will be mounted inside the FSCS.
- Whether the FSCS is to be supplied with terminals for wiring to discrete I/O points, an ADI ModBus EIA-485 interface for controllers that support the ADI ModBus interface, or a hybrid of the two.

When applying the ADI FSCS to the I/A Series BACnet Smoke-Control System, certain programming must be implemented by the control applications to meet the requirements of UL 864 UUKL/UUKL7. Examples of this programming are shown in Figure–5.1 and Figure–5.2.

Figure–5.1 shows a method for implementing support for the FSCS Enable switch, required by UL 864 UUKL/UUKL7. When the switch is in the disabled position, it disables all switch inputs to the FSCS and turns OFF the LED associated with the FSCS Enable switch. As can be seen in the figure, the FSCS Enable and Alarm Silence switch inputs are always enabled, indicated by the green triangle present at the left side of their resource tags. This aspect of each switch is established through the use of the ADI Wizard. The figure also shows an example of the support required for the System Trouble Alarm Silence input from the FSCS.

Figure–5.2 shows an example of a method for implementing support for the System Trouble Annunciation (visual and audible), required by UL 864 UUKL/UUKL7. All individual smoke-control functions that must annunciate a system trouble, as well as lost communications to any smoke-control device, are logically "OR'd" together to generate a single System Trouble signal. This output controls the System Trouble LED at the FSCS. Depending upon the type of FSCS interface being used, this output can either go directly to the ADI ModBus interface resource tags associated with the FSCS, or control a discrete DO point tied to the FSCS. Refer to "[Lost Communications](#)" on [page 80](#) for hardware and FSCS requirements for controlling the System Trouble LED.

Inputs from FSCS (Switches)

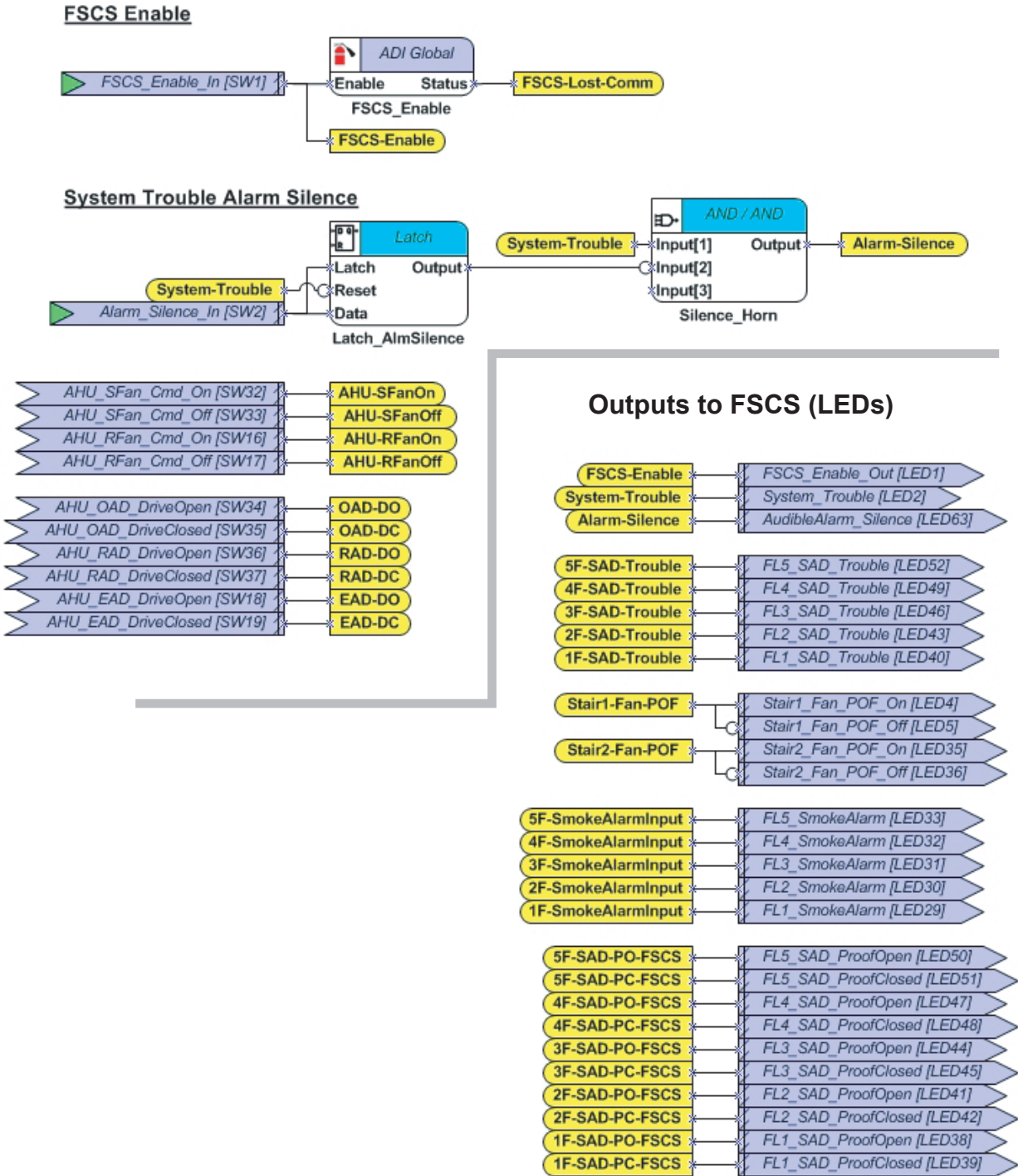

Figure–5.1 FSCS Enable, System Trouble Alarm Silence, and FSCS Communication Status

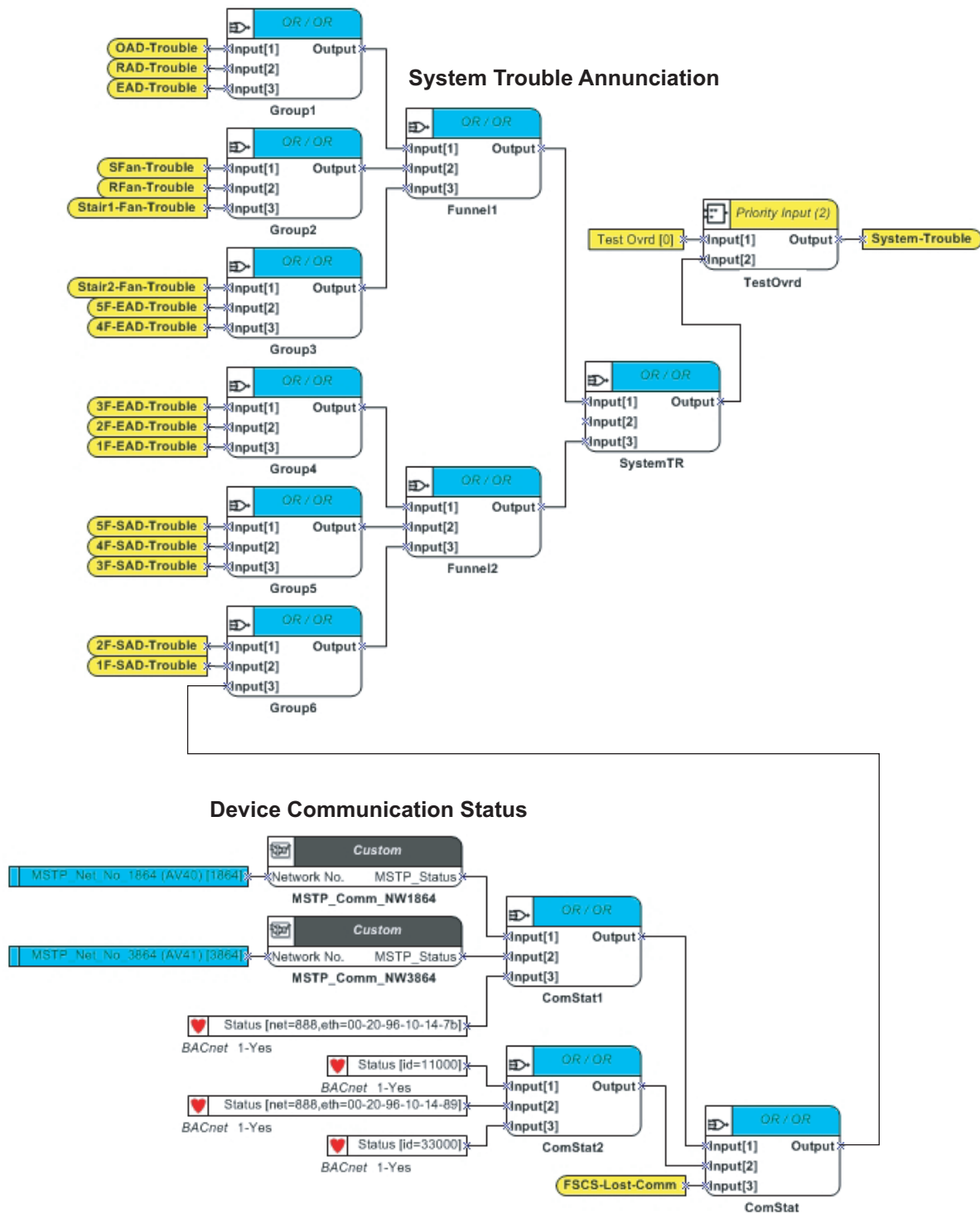

Figure–5.2 Device Communication Status and System Trouble Annunciation

### Approved IP/Ethernet Infrastructure Devices

Two IP/Ethernet switches have been identified as UL 864 Listed and can be used with the I/A Series BACnet MicroNet Smoke-Control System when constructing the IP/Ethernet infrastructure. These switches are shown in Appendix B. The EIS8-100T provides eight 10/100 Mbps RJ-45 ports.

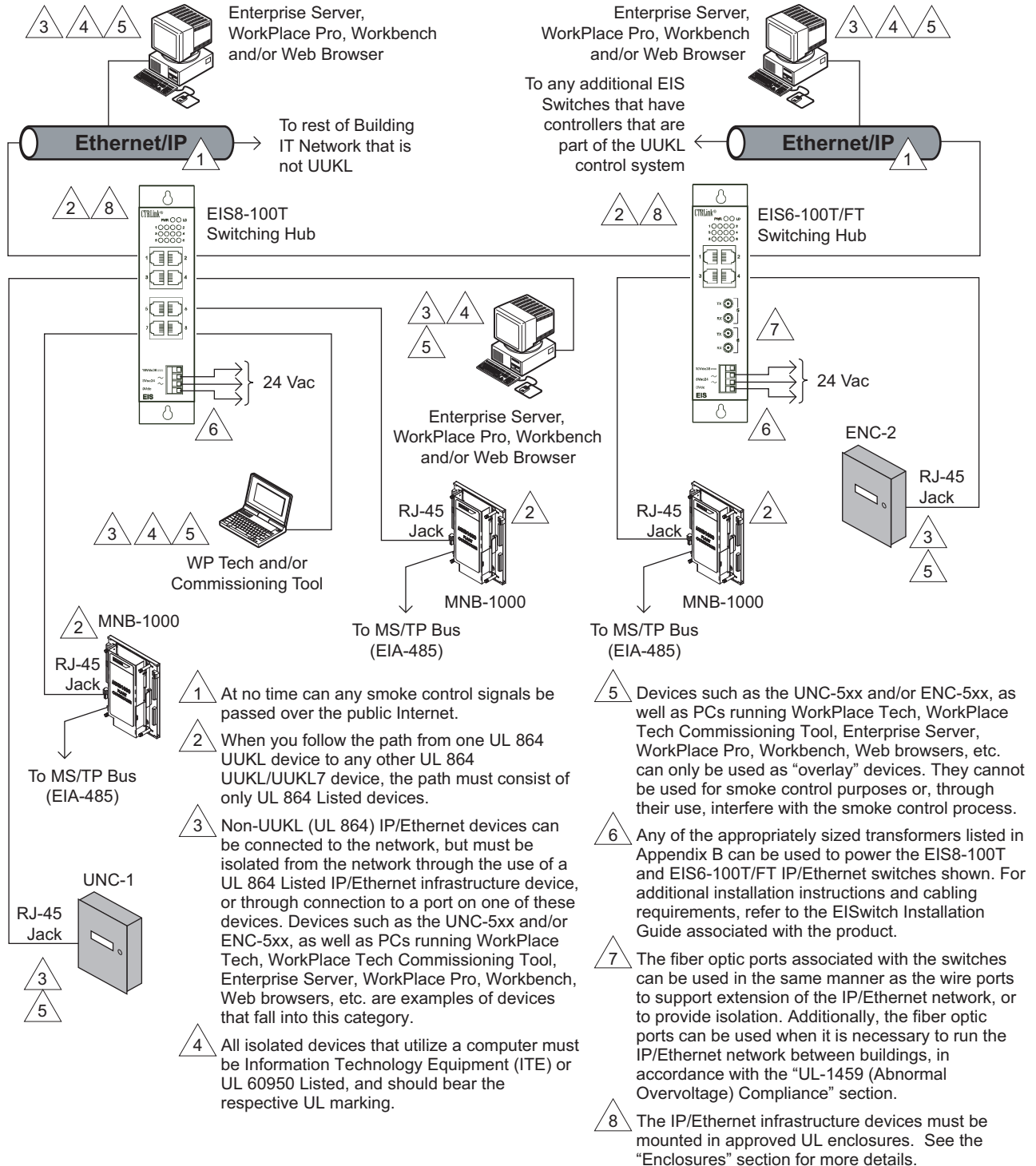

Figure–5.3 IP/Ethernet UL 864 Listed Infrastructure Devices and Isolation.

## **Approved MS/TP Repeaters**

When selecting an MS/TP repeater for use in a UUKL smoke-control system, be sure to consider the following:

- Generally speaking, a UL 864-approved MS/TP repeater can be used on a UUKL smoke-control system's MS/TP bus to either extend wire distance, increase the number of devices allowed (when applicable), or both.
- In most cases, the UL 864-approved MS/TP repeater will be used on a UUKL smoke-control system to isolate the UUKL Listed controllers from those that are not listed.
- When a repeater will be used with I/A Series BACnet MicroNet controllers in a UUKL smoke-control application, it is recommended that you choose an MS/TP repeater that has been specifically tested, as listed in Appendix B.
- When using "b-Link" repeaters, certain installation guidelines must be followed. Figure–5.4 shows an example using the B-LINK-AC-S wire-only repeater. The same installation rules apply to the B-LINK-AC-F-S fiber optic repeater for those items common to both.

### **Coexistence and Isolation of Non-UL 864 Devices on the MS/TP Bus**

When connecting one or more non-UL 864 Listed BACnet devices to an MS/TP bus that is involved in smoke control, a UL 864 Listed MS/TP repeater must be used to isolate those BACnet devices from the rest of the controllers. Figure–5.4 illustrates examples of this isolation. Optionally, instead of using an MS/TP repeater for isolation, the non-UUKL devices can be located together under other MNB-1000 controllers whose MS/TP bus are not involved in smoke control.



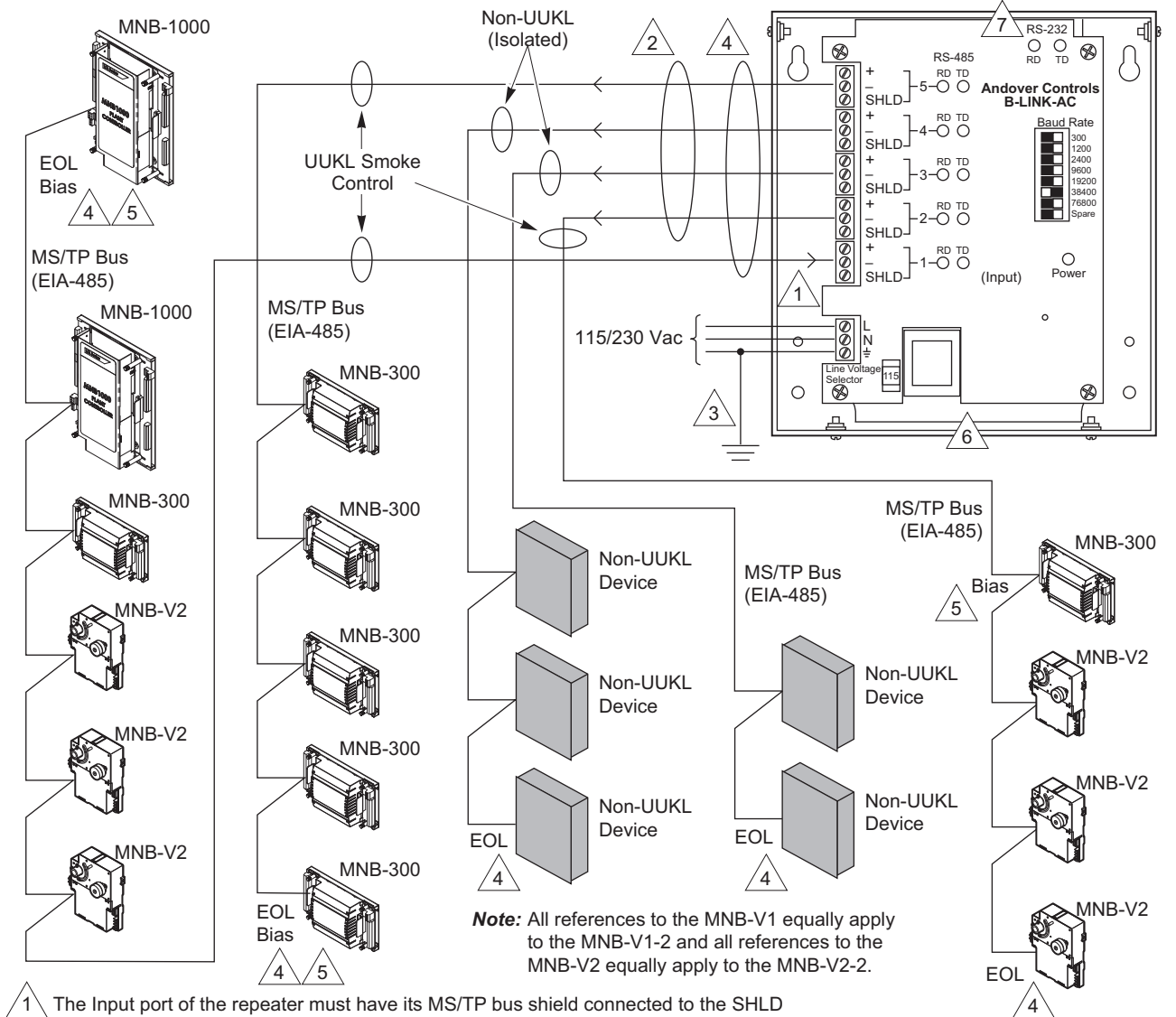

**Note:** All references to the MNB-V1 equally apply to the MNB-V1-2 and all references to the MNB-V2 equally apply to the MNB-V2-2.

- 1 The Input port of the repeater must have its MS/TP bus shield connected to the SHLD terminal, which is isolated from Earth Ground. The incoming MS/TP shield must be grounded at only one point, at a location other than the repeater. Typically this is at the opposite end of the bus, or where the MNB-1000 parent controller resides.
- 2 All four of the repeater's Output ports have their SHLD terminals tied together, and tied to Earth Ground internally, through the power supply's Earth Ground connection. For each MS/TP bus cable leaving these ports, the single point of ground for the shield is at the repeater and, therefore, the shield must not be grounded at any other point on the bus.
- 3 The AC power source for the repeater must provide a known, good, Earth Ground connection to the Earth Ground terminal.
- 4 Anytime the MS/TP repeater is connected to a bus, the jumper-enabled end-of-line (EOL) resistors associated with the MNB-1000 and MNB-300 controllers (on that bus) must be disabled. The same EOL resistor requirements still apply, except that external discrete terminators must be used. The 120 Ω termination resistor (part no. EMSC-546) has been provided for this purpose. If the repeater is the end-of-line for each bus, then each port should have the 120 Ω termination resistor installed between the "MSTP +" and "MSTP -" terminals. Likewise, the last device at the other end of each bus must also have the 120 Ω termination resistor installed between the "MSTP +" and "MSTP -" terminals.
- 5 Bias resistors must still be applied to each bus, as outlined in the EIA-485 Termination and Bias Resistors section.
- 6 The integral enclosure associated with the "B-LINK-AC-S" repeater meets the enclosure requirements of UUKL.
- 7 The RS-232 connection cannot be used in UL 864 smoke control applications.

Figure-5.4 UL 864 Listed MS/TP Repeater and Isolation.

## Use of MNB-1000 IP Switch Feature

IP switching, also known as port bridging, is enabled on the bottom Ethernet IP port (RJ-45 connector) of the MNB-1000 controller. However, when an MNB-1000 controller is applied to a UUKL smoke-control system, this IP switch feature cannot be used. For this reason, in UUKL applications all IP/Ethernet connections must be made to the top Ethernet IP port only. If there is a need to increase the number of IP or Ethernet nodes, the IP infrastructure devices noted earlier must be used. See "[Approved IP/Ethernet Infrastructure Devices](#)" on page 71 and the list of devices in Appendix B.

## Dedicated Supply Air Dampers

In many cases, a dedicated motor-driven damper may need to be installed in the common supply air duct feeding each smoke-control zone. This damper is required to provide smoke zones that are negatively pressurized with respect to all contiguous smoke-control zones, within the response time specified by NFPA 92A and UL 864 UUKL/UUKL7.

---

**Note:**

- UL's acceptance of the MNB-V1 and MNB-V2 MicroNet VAV controllers for UUKL is based on the assumption that negative pressurization of a smoke zone is considered accomplished when the total flow rate (CFM) supplied to the zone drops below 50% of its maximum while its dedicated exhaust damper is fully open.
- UL's acceptance of the MNB-V1 and MNB-V2 MicroNet VAV controllers for UUKL is based on the assumption that positive pressurization of a smoke-control zone is considered accomplished when the total flow rate (CFM) supplied to the zone exceeds 50% of its maximum while its dedicated exhaust damper is fully closed.
- In a smoke-control zone, exhaust and supply air dampers should always be driven to their full-open and full-closed positions. Sufficient differential pressure must be achieved between zones to ensure smoke spread is confined to the zone in which the fire originated.

---

The MNB-V1 and MNB-V2 MicroNet VAV controllers have a 3.0 minute travel time to achieve a 90° rotation when under continuous drive (forced open or closed). Since these controllers have an adjustable travel range from 45° to 90°, the worst case full-stroke travel time can vary from approximately 1.5 to 3.0 minutes. NFPA 92A and UL 864 UUKL/UUKL7 specify that achieving positive and negative pressurization of the smoke-control zones and smoke zones, respectively, must be accomplished within 75 seconds. Therefore, the application must be evaluated to determine if this time can be met without the use of dedicated supply air dampers.

Dedicated supply air dampers are not required if the damper response time is acceptable, under the following conditions:

- Negative pressurization of the smoke zone is considered accomplished when the total flow rate (CFM) supplied to the zone drops below 50% of its maximum while its associated dedicated exhaust damper is fully open.

- Positive pressurization of a smoke-control zone is considered accomplished when the total flow rate (CFM) supplied to the zone reaches 50% of its maximum while its associated dedicated exhaust damper is fully closed.

Additionally, if the local Authority Having Jurisdiction (AHJ) determines that the longer damper travel times specified are acceptable, the dedicated supply air dampers can be omitted.

### Class 2 Powered Devices

All I/A Series BACnet controllers that specify the use of a Class 2 power transformer must use one of the transformers listed in Appendix B. The use of these transformers, in conjunction with the published wiring and installation literature listed in Appendix C, provides compliance with the power-limited circuit requirements of UL 864 and the National Electrical Code (NEC).

### EIA-485 Termination and Bias Resistors

With the exception of MS/TP buses that use the MS/TP repeaters listed in Appendix B, all other MS/TP bus installations must adhere to the application of EOL (end-of-line termination) and Bias resistor jumpers as overviewed here and detailed in the documents referenced in Appendix C. The MNB-1000 and MNB-300 controllers each provide jumpers that can enable or disable EOL and Bias resistors. The MNB-V1 and MNB-V2 controllers are not equipped with these jumpers.

Each MS/TP trunk must have an EOL resistor active at each end. When MNB-1000 and MNB-300 controllers are present at the ends, their EOL jumpers can be placed in the Enabled position to achieve this. If the device at the end of the MS/TP trunk is an MNB-V1 or MNB-V2 controller, then a 120  $\Omega$  resistor, EMSC-546, must be placed across the "MSTP +" and "MSTP -" terminals. This is the EOL resistor specified in Appendix B. No other EOL resistors shall be present on the bus.

For Bias resistors, each MS/TP bus must have a minimum of one, and a maximum of two, sets active. The Bias resistors can be installed at any point on the bus. If two sets are active, each would typically be installed towards one of the ends of the bus. If only one set is active, then it would typically be installed towards the center of the bus length. The MNB-1000 and MNB-300 controllers are each equipped with two Bias resistor jumpers that can be placed in the Enabled or Disabled positions for this purpose. The MNB-V1 and MNB-V2 controllers do not feature user-configurable bias resistors.

### System Self-Tests

To maintain system integrity, dedicated system equipment must incorporate an automatic weekly self-test of each smoke-control function. The self-test consists of the smoke-control system automatically commanding the associated function to operate, and expecting that the associated proof sensor operates within a specified period of time. The response time is 60 seconds for a fan and 75 seconds for a damper. For a discussion of response times, refer to "[Response Time](#)" on page 8.

Valid proof sensor operations are not required to be annunciated. However, the lack of an expected proof sensor operation must produce, at the FSCS, an audible trouble signal and an indication (with an LED) of the specific device that did not operate. Whenever an automatic test of the dedicated system equipment fails, annunciation of the failed state must be maintained

at the FSCS until acknowledged by an operator. This acknowledgment is from the FSCS. It is acceptable for the failure state to require manual clearing from the I/A Series BACnet system to return it to normal operation, once the acknowledgment has been made.

## Transformers

Only the transformers listed in Appendix B can be used with I/A Series BACnet controllers (UL 864 UUKL/UUKL7 Listed) that directly take part in smoke-control operation. Certain transformers must be mounted in enclosures to meet UL 864 UUKL/UUKL7 requirements, as shown in Table-5.1.

Table-5.1 Transformer Enclosure Requirements.

Transformer	Description	Enclosure Required
EMSC-541 <sup>a</sup>	50 VA, 120 V Pri., 24 V Sec., 50/60 Hz, Fused (nonreplaceable) Primary	<ul style="list-style-type: none"> <li>No Enclosure Required</li> </ul>
EMSC-542 <sup>a</sup>	100 VA, 120 V Pri., 24 V Sec., 50/60 Hz, Fused (nonreplaceable) Primary	<ul style="list-style-type: none"> <li>No Enclosure Required</li> </ul>
EMSC-543 <sup>a</sup>	240 VA, 120 V Pri., 24 V Sec., 60 Hz, Fused (nonreplaceable) Primary	<ul style="list-style-type: none"> <li>UL-50 Listed Enclosure</li> </ul>
EMSC-583	75 VA, 120 V Pri., 24 V Sec., 50/60 Hz, Class 2	<ul style="list-style-type: none"> <li>Uses conduit fittings or</li> <li>UL-50 Listed Enclosure</li> </ul>
EMSC-616	75 VA, 120 V Pri., 24 V Sec., 50/60 Hz, Class 2, Foot Mount Single Hub UL-Listed w/Circuit Breaker, Mounting Plate Included	<ul style="list-style-type: none"> <li>Uses conduit fittings or</li> <li>UL-50 Listed Enclosure</li> </ul>
EMSC-618	96 VA, 120 V Pri., 24 V Sec., 50/60 Hz, Class 2, Foot Mount Single Hub UL-Listed w/Circuit Breaker, Mounting Plate Included	<ul style="list-style-type: none"> <li>Uses conduit fittings or</li> <li>UL-50 Listed Enclosure</li> </ul>

a. EMSC-541, EMSC-542, and EMSC-543 are not approved for use in smoke control applications in Canada, covered in ULC Standard ULC-S527-99.

## Enclosures

Some of the controllers, repeaters, and IP infrastructure devices listed in Appendix B do not feature integral enclosures. These devices must be mounted inside one of the enclosures approved for smoke-control applications. Table-5.2 lists these devices and the corresponding, required enclosures.

Table-5.2 Approved Enclosures for Smoke Control Applications.

Devices	Enclosures					
	MNB-1000-ENC	MNB-300-ENC	MNA-FLO-1	FSCS Enclosure <sup>a</sup>	Integral	UL-50 Listed
MNB-1000	X			X		X
MNB-300		X		X		X
MNB-V1			X			X
MNB-V2			X			X
MS/TP Repeaters					X	X
IP Switches						X

a. If allowed by the FSCS manufacturers listing. ADI FSCS panels provide this option.

## Wiring

The FSCS can interface to I/A Series MicroNet BACnet controllers, either through the ADI ModBus EIA-485 (RS-485) interface of the MNB-1000 or through individual I/O points.

### ADI ModBus EIA-485 Interface

The Remote I/O bus of the MNB-1000 controller, when used with the ADI FSCS ModBus interface, requires use of the same type of wiring as specified for the MS/TP bus (Table–5.3). The MNB-1000 will typically be mounted inside the same enclosure as the FSCS. However, if the MNB-1000 is located external to the FSCS panel, then the wire length between the controller and the UUKL smoke-control system must not exceed 20 feet, and the I/O wiring must be run in conduit. End-of-line terminations must be present at both ends of the bus. This is accomplished by placing the I/O EOL jumper of the MNB-1000 in the Enabled position, and by installing a termination resistor at the FSCS end of the bus. Refer to the documentation associated with the ADI FSCS for additional information regarding ADI’s EIA-485 ModBus termination requirements.

### Individual I/O Points

Anytime discrete I/O points are used and the FSCS manufacturer is approved to allow the installation of I/A Series BACnet controllers inside the FSCS panel, the distance and conduit requirements listed in Table–5.3 are not applicable. In all such cases, the wiring to the FSCS is still considered unsupervised.

The ADI ModBus interface wiring and I/O wiring that connects the I/A Series BACnet controllers to either the UUKL listed FSCS or the UOJZ listed fire alarm panel, are considered unsupervised. When this wiring is external to the UUKL listed FSCS or UOJZ listed fire alarm panel, the I/A Series BACnet controllers must be mounted within 20 feet of the panel to which they are connected, and the wiring must be run in conduit. Table–5.3 lists the general requirements for wiring associated with I/A Series BACnet smoke-control applications.

**Table–5.3 Wiring Requirements.**

Wiring	Status
IP LAN	Supervised by object programming
Ethernet LAN	Supervised by object programming
MS/TP Bus	Supervised by object programming
ADI ModBus Interface	Supervised by object programming
I/O to FSCS	Unsupervised. When the controller and the FSCS are not located in the same panel, wiring must be run in conduit and controllers must be located within 20 ft of the panel
I/O to Fire Alarm Panel	Unsupervised. Wiring must be run in conduit and controllers must be located within 20 ft of the panel.
Remaining I/O	Unsupervised

## **Hardware and Firmware Upgrade Process Requirements**

Each MNB-1000, MNB-300, MNB-V1 or MNB-V2 controller is shipped from the factory with a label affixed to the unit, documenting its original firmware version. However, the firmware in these controllers may be field-upgraded by authorized personnel, using any version of firmware that is approved for use in UUKL Listed systems. Because of this, a means must be found to identify a unit's currently installed firmware version. One such means is the WorkPlace Commissioning Tool. Using this tool, you can browse the network of controllers and employ one of two methods for identifying a controller's firmware version. In the first method, you view the controller's Properties, which shows the firmware version, as well as other data. In the second method, you enable the Firmware column on the Commissioning Tool's main page so that it displays the current firmware version for each controller.

## **UL-1459 (Abnormal Overvoltage) Compliance**

When applying I/A Series BACnet controllers to a UUKL smoke-control application, it is acceptable for the communication trunks (LANs and buses) to be run from one building to another. Whenever the cabling leaves a building in such an application, it must be isolated from the next building through the use of fiber optic cable. An MS/TP bus can be converted to fiber optic cable through use of the appropriate UUKL-approved repeater. Ethernet and IP LANs can be converted to fiber optic cable through the use of the appropriate UUKL-approved IP infrastructure devices. Refer to ["Approved MS/TP Repeaters" on page 72](#) and ["Approved IP/Ethernet Infrastructure Devices" on page 71](#) for more information on the use of these types of devices.

## **General Comments**

### **FSCS Requirement**

In some cases, the FSCS may be considered optional. The Authority Having Jurisdiction (AHJ) determines whether an FSCS is required.

### **MNB-1000 Using ADI ModBus Interface**

When using the MNB-1000's ADI ModBus EIA-485 (RS-485) interface to communicate with an ADI ModBus FSCS, consider the following:

- The MNB-1000's unused I/O points, S-Link interface, and MS/TP bus can be used for other related or unrelated purposes, as long as those purposes do not adversely impact the smoke-control sequence or violate any of the UUKL installation requirements.
- Only UUKL listed or approved devices can be located inside the ADI FSCS panel.
- If an FSCS panel from a vendor other than ADI is used, check the requirements of that vendor to determine the available mounting options.

### **Job Estimating**

When estimating a job using I/A Series BACnet devices for controlling smoke-control equipment (requiring UL 864 UUKL/UUKL7 and NFPA 92A compliance), consideration must be given to the number of additional devices that are required for end process verification and interfacing to the

FSCS. As seen below, whenever an MNB-1000 controller with ADI ModBus support is used to interface with an ADI ModBus FSCS, the number of additional points required to support the FSCS is substantially reduced.

### Fans

For most fans, the following additional points are required:

- One DI (digital input) point for fan flow.
- Two DI points to serve the ON/OFF fan-control commands from the FSCS.
- One DO (digital output) point to send proof of the current fan condition back to the FSCS.

---

**Note:** The two DI points for the ON/OFF commands from the FSCS, and the one DO point for the proof of current fan condition, are not required if the MNB-1000 with ADI ModBus support is used to interface with an ADI FSCS. These additional points are only required if discrete I/O points are hardwired to an FSCS.

---

### Dampers

For most dampers, the following additional points are required:

- Two DI points for monitoring the end-of-travel switches.
- Two DI points for the drive open and drive closed commands from the FSCS for controlling the dampers.
- Two DO points to send proof of position back to the FSCS.

---

**Note:** The two DI points for the drive open/closed commands from the FSCS and the two DO points for the proof of position will not be required if the MNB-1000 with ADI ModBus support is used to interface with an ADI FSCS. These additional points will only be required if discrete I/O points are hardwired to an FSCS.

---

In some cases, a flow sensor or switch may be used to determine damper position. In these situations, only one AI (analog input) or DI may be required, instead of the two as noted above.

Additional points are required for monitoring the fire and smoke alarm contacts of the UOJZ listed fire alarm panel, and for controlling the trouble LEDs (general and dedicated) associated with the FSCS. The number of points required for these functions varies with each application but must be considered when estimating the job.

---

### Note:

- The additional points required to control the trouble LEDs associated with the FSCS are not required if the MNB-1000 with ADI ModBus support is used to interface with an ADI FSCS. These additional points are only required if discrete I/O points are hardwired to an FSCS.
  - Any UOJZ listed fire alarm panel with programmable N.O. (normally open) relay contacts can be used with I/A Series BACnet controllers.
-

## Spare I/O Points

When I/A Series BACnet controllers interface to the FSCS or fire alarm panel, any spare I/O points that exist on these controllers can be used for other control purposes, as long as those purposes do not adversely impact the smoke-control sequence or violate any of the UUKL installation requirements.

## Lost Communications

### Discrete I/O

In all I/A Series BACnet smoke-control systems where discrete I/O wiring is used to control the FSCS, one controller must be connected to the FSCS to control the system trouble output. The system trouble output must be applied in such a way that anytime this controller loses communication with its parent controller, or loses its power source, the system trouble output assumes the failure state.

**Example—Lost Communication:** A DO point within an I/A Series BACnet controller is connected to normally closed (N.C.) contacts within the FSCS. These contacts are, in turn, wired to the system trouble input. Whenever the controller containing the DO point is powered and communicating with its parent controller, and no other system troubles exist, the DO point is commanded ON and the N.C. contacts are open. This is the normal state, in which the system trouble indicator and audible alarm are OFF. If communication between this controller and its parent controller fails, or this controller loses power, the DO point is de-energized and the N.C. contacts close, causing the FSCS to illuminate the system trouble visual indicator and audible signal.

### Lost Communication Between MNB-1000 and FSCS

When the MNB-1000 controller communicates with the ADI FSCS through the ADI ModBus interface, any loss of communication between these devices must cause the FSCS to activate its system trouble LED and audible alarm. Support must also be provided for silencing the audible annunciation in this situation. The ADI FSCS referenced in Appendix B provides, in its firmware, support for these features. A Communications Timeout value is provided on the Configuration tab of the ADI Object Configuration screen, within the ADI Wizard. This value defines the amount of time that can elapse, without communication, before the FSCS indicates a lost communication fault. More information is provided in the *WorkPlace Tech Tool 5.7 Engineering Guide Supplement*, F-27356.

### IP, Ethernet, and MS/TP Networks

To assure compliance with UL mandated response times, all smoke-control systems require the use of object programming to detect lost communications between controllers on the IP, Ethernet, and MS/TP networks. Figure–5.5 shows the MSTP Status and Device Status objects available for this purpose. In the case of the Device Status object, the five possible configurations are included. Their design requires no timing adjustments by the application engineer. In some cases, they will be dependent upon network performance. UL states that the time between the occurrence of a transmission fault and its trouble annunciation shall not be more than 200 seconds.



Each smoke-control system must have at least one MNB-1000 controller present that coordinates the monitoring of the communication status of all devices on the various networks. As such, this controller is considered the master device of the network. This is the controller that provides the ADI ModBus interface and is typically located inside the FSCS panel. All communication status objects associated with the smoke-control system reside in this master controller. No communication status objects are required in any of the other controllers in the system.

The MSTP Status and Device Status objects are described in detail in the *WorkPlace Tech Tool 5.7 Engineering Guide Supplement*, F-27356, which is referenced in Appendix C. In all cases, the Status output of the objects is “100” if communication is lost and “0” if communication is good. A synopsis of their function and application in smoke-control systems is given in the notes in Figure–5.5.

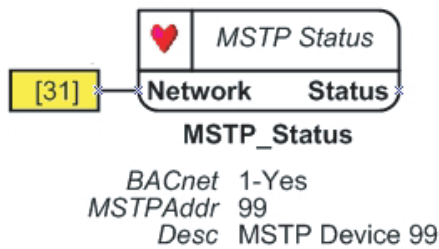

**Example A – MSTP Status**

This MSTP Status object is configured to monitor a single MSTP device. The monitored device is specified by the value of the object's MSTPAddr (MSTP address) property and the network number connected to the Network input property. In this case, device address 99 on network 31 is being monitored. This is the object most frequently used to monitor an MSTP device connected to an MNB-1000 controller.

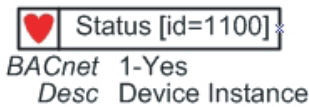

**Example C – Device Status**

In this example, the Device Status object is configured to monitor a single device based on its Instance Number. To do this, "Device ID" was selected as the device type and the Device Instance was set to "1100." With these settings, this object is monitoring device instance 1100 on the BACnet network (regardless of its communications type). This object is most frequently used when it is necessary to poll for the device status based solely on the Instance Number.

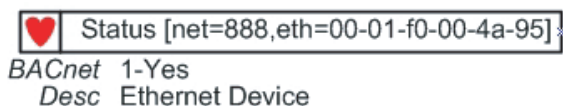

**Example E – Device Status**

In this example, the Device Status object is configured to monitor a single BACnet Ethernet device. To do this, "Ethernet" was selected as the device type, the Network Number was set to "888," and the Ethernet MAC Address was set to "00-01-F0-00-4A-95". This example is monitoring a BACnet Ethernet device whose address MAC Address is "00-01-F0-00-4A-95" on network 888. This object is most frequently used when it is necessary to poll for the device status of a BACnet Ethernet configured MNB-1000 controller.

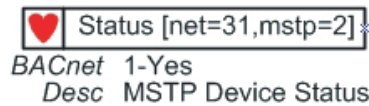

**Example B – Device Status**

In this example, the Device Status object is configured to monitor a single MSTP device, device address 2 on network 31. The object's Configuration screen allows you to select different types of communication networks, including MS/TP. To monitor the chosen device, "MS/TP" was selected as the device type, the Network Number was set to "31," and the MS/TP Address (set by DIP switch) was set to "2." This object is most frequently used when it is necessary to poll for the device status based on Network Number and MSTP Address.



**Example D – Device Status**

In this example, the Device Status object is configured to monitor a single BACnet IP device. To do this, "BACnet IP" was selected as the device type, the Network Number was set to "1876," the IP Address was set to "10.1.144.99," and the IP Port was set to "9." With these settings, this object is monitoring a BACnet IP device whose address is "10.1.144.99:9" on network 1876. This object is most frequently used when it is necessary to poll for the device status of an MNB-1000 controller configured for BACnet IP.

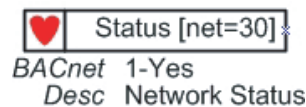

**Example F – Device Status**

In this example, the Device Status object is configured to monitor all devices on an MSTP bus under an MNB-1000 controller. Using this object in this manner requires that first an MSTP Status object is defined for each controller (to be monitored) on the MSTP bus. To set up this Device Status object, "Network" was selected as the device type and the Network Number was set to "30." With these settings, the Device Status object is configured to monitor the status of all MSTP Status objects that have been defined in the MNB-1000 controller and assigned a network number of 30. This object is specifically designed to logically "OR" the defined group of MSTP devices on a single network and provide a single Status output value.

Figure–5.5 Available Communication Status Monitoring Objects.

### **Custom Objects for MS/TP Communication Status**

To expedite the process of setting up communication status monitoring of multiple MS/TP devices under multiple MNB-1000 controllers, two Custom Objects have been created and placed on an Application Objects Stencil as a published application. Go to Tech Zone, on the Schneider Electric Web site, "The Source." These objects provide a means to add a single custom object for each MS/TP network (under an MNB-1000 controller) to be monitored. They automatically create and add, to the application, all of the objects required to monitor a network of 127 MS/TP devices. The user simply changes the network number associated with each device and deletes the MSTP Status objects for any controllers that are not required or present. The use of these Custom Objects, in conjunction with variations of the MSTP Status and Device Status objects discussed previously, provide the monitoring of communication status required to meet UUKL for the complete smoke-control network. In many cases, it is necessary to logically "OR" the outputs of these objects to generate a single output that is combined into the System Trouble LED control signal.

### **Preventing False Indication of Lost Communications**

When downloading to controllers, resetting them, or cycling power to them, the system may annunciate a system trouble, which lights the System Trouble LED and sounds an audible alarm at the FSCS. Since these situations should only occur when a user with manager-level access ("programmer" or "authorized person") makes adjustments to the system, that user must take appropriate steps to prevent false indications of lost communication, by temporarily overriding the System Trouble signal. Such overrides should only be performed by authorized personnel.

In this case, "false" implies that the loss of communication was not due to a failure but was, instead, caused by servicing of the system. Once the manager-level user has completed their activities, the temporary overrides must be removed and the system verified as having returned to a fully functional state.

## **Use of BACnet Priority Structures**

An I/A Series MicroNet BACnet smoke-control system should be designed to use the BACnet priority structures associated with many of the BACnet objects. Adherence to the intended functional description for each priority input provides the system-wide support necessary to assure the integrity of the smoke-control system, while allowing other BACnet devices to provide overlay HVAC and day-to-day control. Therefore, use of the "Manual Life Safety (1)" and "Automatic Life Safety (2)" priority inputs of various objects on the application level lays the foundation for the use of non-UUKL devices, such as the UNC-520 and ENC-520 controllers, as overlay devices. These devices must be isolated (see ["Coexistence and Isolation of Non-UL 864 Devices on the MS/TP Bus" on page 72](#)) and must not in any way adversely impact the ability of the smoke-control system to perform its function. The Command Priority object has been created specifically for this purpose and should be used whenever the integrity of the BACnet priority structures must be maintained.

## Use of Transient Suppressor on MNB-300 DO

If one or more I/O points of an MNB-300 are used for smoke control, then every used DO (Triac) point must have an EMSC-621 Transient Suppressor installed. The EMSC-621's gray wires connect to any two used outputs (for example, TO1 and TO2) and the green wire connects to either 24 COM or GND, on the power connector. Figure-5.6 shows three typical scenarios for connecting the EMSC-621 to the DO (Triac) terminals.

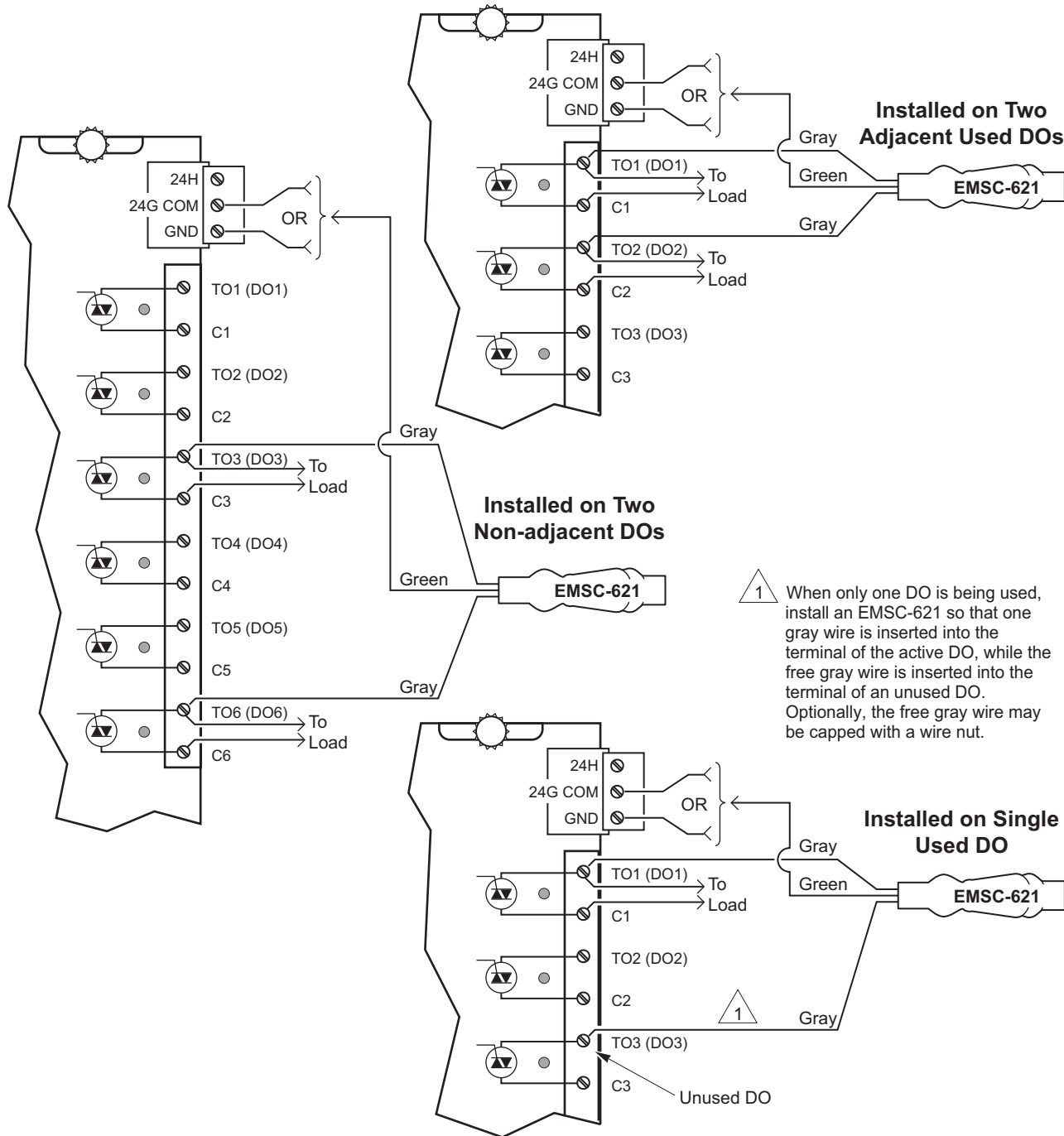

Figure-5.6 Installation of Transient Suppressor EMSC-621 on DOs of MNB-300.

**Multiple  
MNB-V1/-V2  
Controllers for  
Pressure  
Summation**

If multiple MNB-V1 and/or MNB-V2 VAV controllers are used to control a smoke-control zone, it is acceptable to sum the CFM flow from each terminal box together, to determine whether a zone is positively or negatively pressurized. The same guidelines as those noted in "[Dedicated Supply Air Dampers](#)" on page 74 apply here.

**VAV Zone Pressure  
or Position  
Indication**

It is acceptable to use the FLOW output from the Pressure Transducer objects and the POSITION output from the VAV Actuator objects of MNB-V1 and MNB-V2 controllers to indicate the current pressurization of a zone or the position of the zone's VAV damper. Both of these values are presented as BACnet objects, for this purpose.

**I/A Series BACnet  
Applications**

Published I/A Series MicroNet BACnet applications can be used on smoke-control jobs, provided they do not adversely impact the smoke-control sequences or violate any of the requirements of the UL 864 UUKL Listing or the AHJ. For example, UL accepts the use of the "DUI\_App" application (reading five DI points from one UI point) to minimize the number of controllers required to interface to the FSCS (when an I/O interface is used), although its use must be verified as acceptable with the local AHJ.



---

# ***Appendix A***

## ***Additional Information***

This appendix contains information related to the various circuits used in an I/A Series MicroNet BACnet smoke-control system.

### **MicroNet BACnet Controllers**

Four hardware platforms for MicroNet BACnet controllers are used in smoke control: the MNB-300, the MNB-V1, the MNB-V2, and the MNB-1000. Each of these platforms is described in the following sections.

#### **Common Controller Features**

While all controller platforms differ by their physical characteristics and numbers and types of I/O points, all controller platforms provide the following common features:

- 24 Vac powered.
- Capability to function in standalone mode or as part of an I/A Series building automation network.
- Support for a digital MicroNet sensor via a Sensor Link (S-Link) bus.
- Sequence of operation and BACnet image are fully programmable using WorkPlace Tech Tool (WP Tech) 5.7 or greater.
- Extensive BACnet object and services support.
- DIP switch for setting the physical address.
- LED indication of MS/TP communication link and activity, and controller status.
- Isolated EIA-485 (formerly RS-485) transceiver for MS/TP communications.

Firmware upgradeable over the network or directly to the controller.

## MNB-300 Unitary Controller

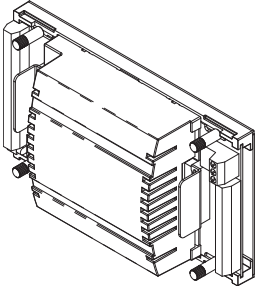

The I/A Series MicroNet BACnet Unitary Controller, MNB-300, is an interoperable controller with native BACnet MS/TP communications support. The controller features Sensor Link (S-Link) support, LED status and output indication, screw terminal blocks, as well as a panel-mount sub-base with removable electronics module. The MNB-300 also includes one end-of-line (EOL) termination and two bias resistors, both of which are jumper-selectable.

When programmed using WP Tech, the MNB-300 provides a wide range of control strategies for packaged rooftop, heat pump, fan coil, unit ventilator, and similar applications.

### Unique Features

In addition to common MicroNet BACnet controller features ("[Common Controller Features](#)" on page 1), the MNB-300 offers the following:

- Removable electronics module that mates with panel-mounted subbase.
- IAM button for BACnet "I am" message broadcast.
- Integral MS/TP jack for direct connection of a PC with the WP Tech.
- Removable terminals for power and communications, to facilitate commissioning.
- LED indication of UO and TO state.

### Memory Available

Table–A.1 MNB-300 Available Memory.

Model Number	Flash	SRAM	SDRAM	EEPROM	FRAM
MNB-300	256 KB	8 KB	n/a	4 KB	8 KB

### Physical I/O Points

Table–A.2 MNB-300 Inputs and Outputs.

Model Number	Inputs and Outputs		
	UI	UO	DO (Triac)
MNB-300	6	3	6

Refer to "[Input and Output Specifications](#)" on page 8 for a detailed discussion of each input or output type.

### Time Clock

The MNB-300 controller uses a software clock. This software clock defaults to a predefined Date/Time following a reset.



Wiring Terminals

Refer to Figure-A.1 for the power and network communications wiring connections available on the MNB-300 controller.

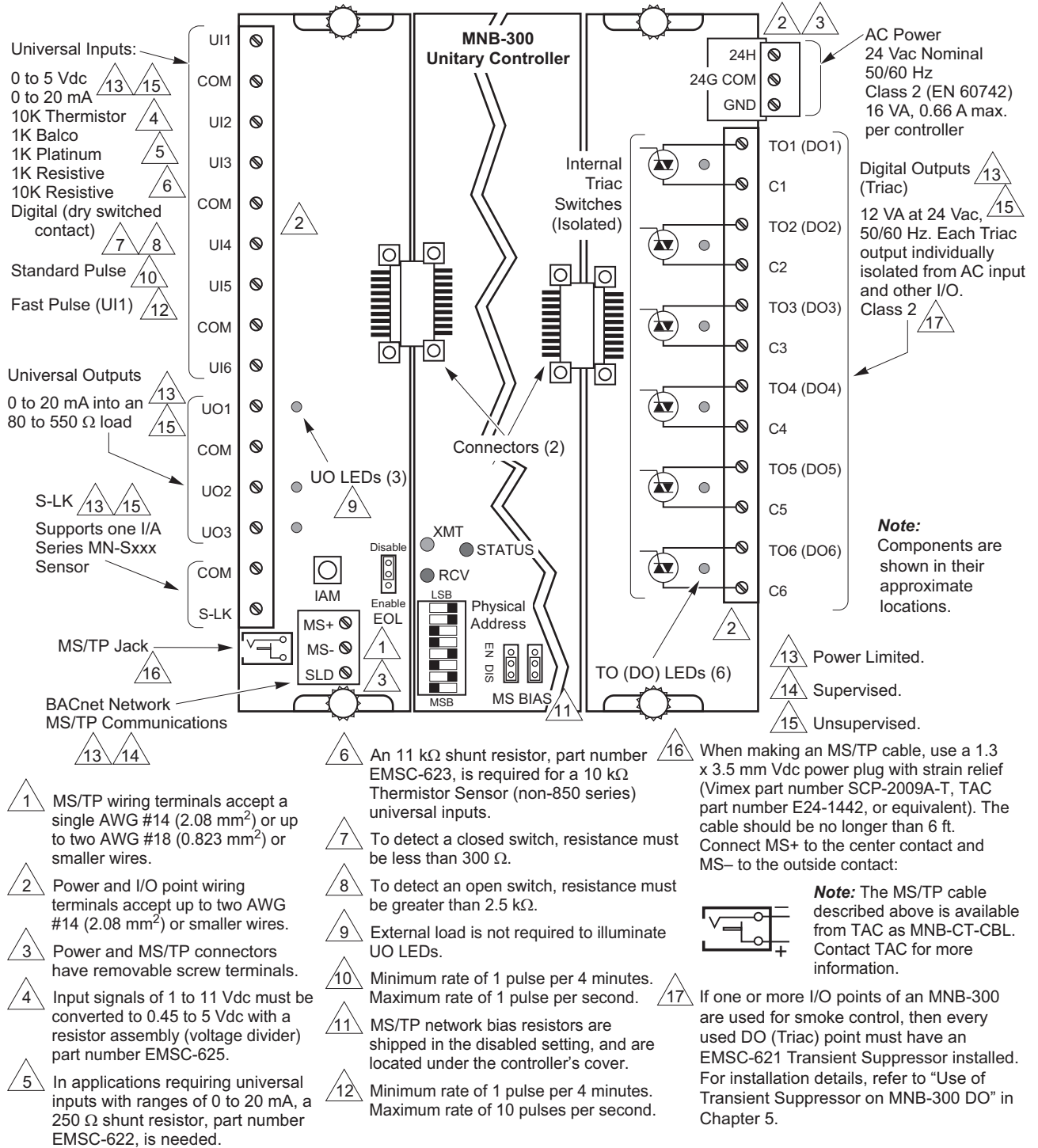
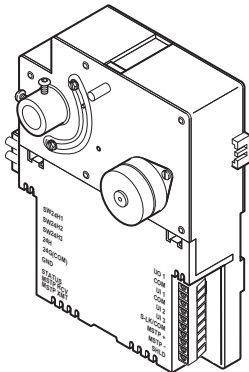

Figure-A.1 MNB-300 Terminal Connections.

## MNB-V1, MNB-V2 VAV Controllers



The I/A Series MicroNet BACnet VAV (Variable Air Volume) Controllers, MNB-V1 and MNB-V2, are interoperable controllers with native BACnet MS/TP communications support. Both models incorporate: an integral actuator with manual override; an integral, patented, pressure transducer; three universal inputs; Sensor Link (S-Link) support; LED status indication; and over-the-shaft damper mounting. The MNB-V1 controller is designed specifically for cooling applications, while the MNB-V2 controller adds digital and universal outputs that make it suitable for additional VAV applications.

When programmed using WP Tech, these controllers provide a wide range of control strategies for pressure-dependent and pressure-independent terminal boxes, with or without reheat capabilities.

---

**Note:** Throughout this manual, all references to the MNB-V1 equally apply to the MNB-V1-2 and all references to the MNB-V2 equally apply to the MNB-V2-2.

---

### Unique Features

In addition to common MicroNet BACnet controller features ("[Common Controller Features](#)" on page 1), the MNB-V1 and MNB-V2 offer the following:

- Air balancing performed using WorkPlace Flow Balance Tool (WPFBT).
- Integrated packaging with actuator, pressure transducer, and controller.
- Integral actuator features manual override and travel limit stops for easy set up and adjustment.
- Enclosure approved for use in air plenums.
- Damper position feedback to the BACnet Building Automation System (BAS) via integral hall effect sensor.
- Stable flow control down to 0.004 in. W.C. (0.996 Pa) differential pressure.

### Memory Available

Table–A.3 MNB-Vx Available Memory.

Model Number	Flash	SRAM	SDRAM	EEPROM	FRAM
MNB-V1, MNB-V2	256 KB	8 KB	n/a	4 KB	n/a

### Physical I/O Points

Table–A.4 MNB-Vx Inputs and Outputs.

Model Number	Inputs and Outputs		
	UI	UO	DO (Triac)
MNB-V1	3	0	0
MNB-V2	3	1	3

Refer to the "[Input and Output Specifications](#)" on page 8 for a detailed discussion of each input or output type.

### Time Clock

The MNB-V1 and MNB-V2 controllers use a software clock. This software clock defaults to a predefined Date/Time following a reset.

Wiring Terminals

Refer to Figure-A.2 for the power and network communications wiring connections available on the MNB-V1 and MNB-V2 controllers.

**Note:** Asterisks (\*) indicate terminals that apply to the MNB-V2 controller but not to the MNB-V1.

**Note:** Components are shown in their approximate locations.

**Note:** All references to the MNB-V1 equally apply to the MNB-V1-2 and all references to the MNB-V2 equally apply to the MNB-V2-2.

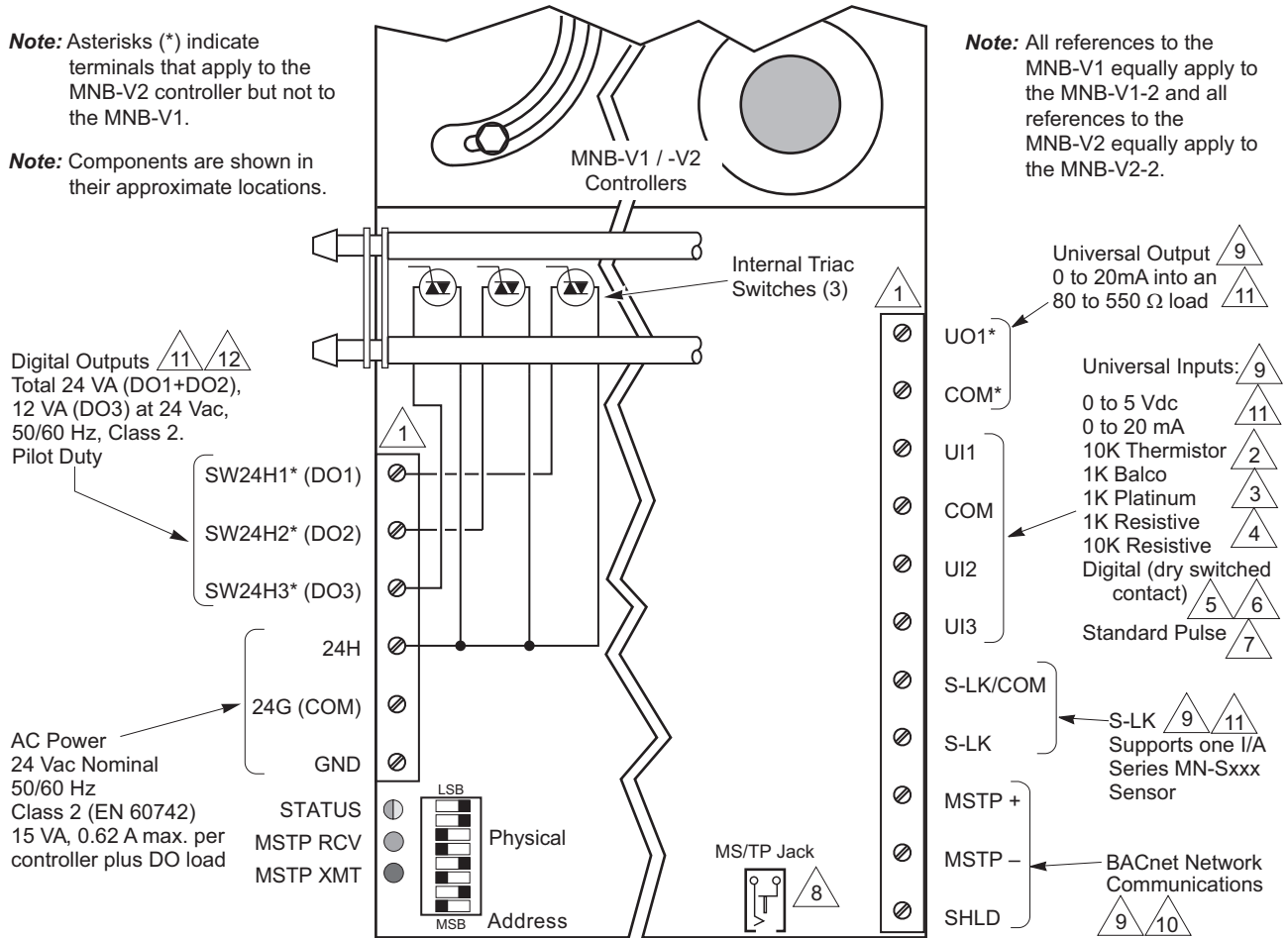

- 1 Fixed screw terminals that accept a single AWG #14 (2.08 mm<sup>2</sup>) wire or up to two AWG #18 (0.823 mm<sup>2</sup>) or smaller wires.
- 2 Input signals of 1 to 11 Vdc must be converted to 0.45 to 5 Vdc with a resistor assembly (voltage divider), part number EMSC-625.
- 3 In applications requiring universal inputs with ranges of 0 to 20 mA, a 250 Ω shunt resistor, EMSC-622, is needed.
- 4 An 11 kΩ shunt resistor, EMSC-623, is required for a 10 kΩ Thermistor Sensor (non-850 series) universal inputs.
- 5 To detect a closed switch, maximum resistance must be less than 300 Ω.
- 6 To detect an open switch, minimum resistance must be greater than 2.5 kΩ.

- 7 Minimum rate of 1 pulse per 4 minutes. Maximum rate of 1 pulse per second.
- 8 When making an MS/TP cable, use a 1.3 x 3.5 mm Vdc power plug with strain relief (Vimex part number SCP-2009A-T, TAC part number E24-1442, or equivalent). The cable should be no longer than 6 ft. Connect MS+ to the center contact and MS- to the outside contact:  
**Note:** The MS/TP cable described above is available from TAC as MNB-CT-CBL. Contact TAC for more information.
- 9 Power Limited.
- 10 Supervised.
- 11 Unsupervised.
- 12 MNB-V2 DO wiring, which is non-power limited, cannot be routed with any other device wiring that is power limited. For additional information, refer to "Intermixing of Cables," in Appendix A.

Figure-A.2 MNB-Vx Terminal Connections.

## MNB-1000 Plant Controller

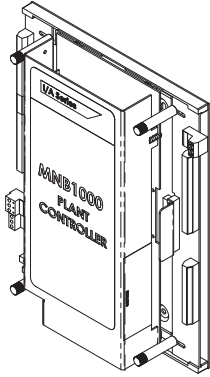

The I/A Series MicroNet BACnet Plant Controller, MNB-1000, is an interoperable controller with native BACnet MS/TP communications support. The controller features Sensor Link (S-Link) support, LED status and output indication, two Ethernet ports, and screw terminal blocks.

The MNB-1000's sequence of operation and BACnet image are fully programmable using WP Tech, and can be applied to a wide range of mechanical equipment. Typical applications include central station air handlers, VAV air handlers, and cooling towers.

### Unique Features

In addition to common MicroNet BACnet controller features ("[Common Controller Features](#)" on page 1), the MNB-1000 offers the following:

- IAM button for BACnet "I am" message broadcast.
- Integral MS/TP jack for direct connection of a PC with the WP Tech.
- LED indication of Ethernet communication link and activity, DO state, and UO state.
- Application-programmable LED provides on/off indication of a user-defined application parameter.
- BACnet router functionality.
- 72 hour, battery-backed real time clock.

### Memory Available

Table–A.5 MNB-1000 Available Memory.

Component	Flash	SRAM	SDRAM	EEPROM	FRAM
μC	128 KB	4 KB	n/a	4 KB	n/a
Motherboard	n/a	256 KB	n/a	128 KB	n/a
Engine (Core)	32 MB	n/a	64 MB	1 Kb	n/a
Engine (Boot)	2 MB	n/a	n/a	n/a	n/a

### Physical I/O Points

Table–A.6 MNB-1000 Inputs and Outputs.

Model	Inputs and Outputs			
	UI	DI	UO	DO (Triac)
MNB-1000	12	4	8	8

Refer to the "[Input and Output Specifications](#)" on page 8 for a detailed discussion of each input or output type.

Wiring Terminals

Refer to Figure-A.3 for the wiring connections available on the MNB-1000 controller.

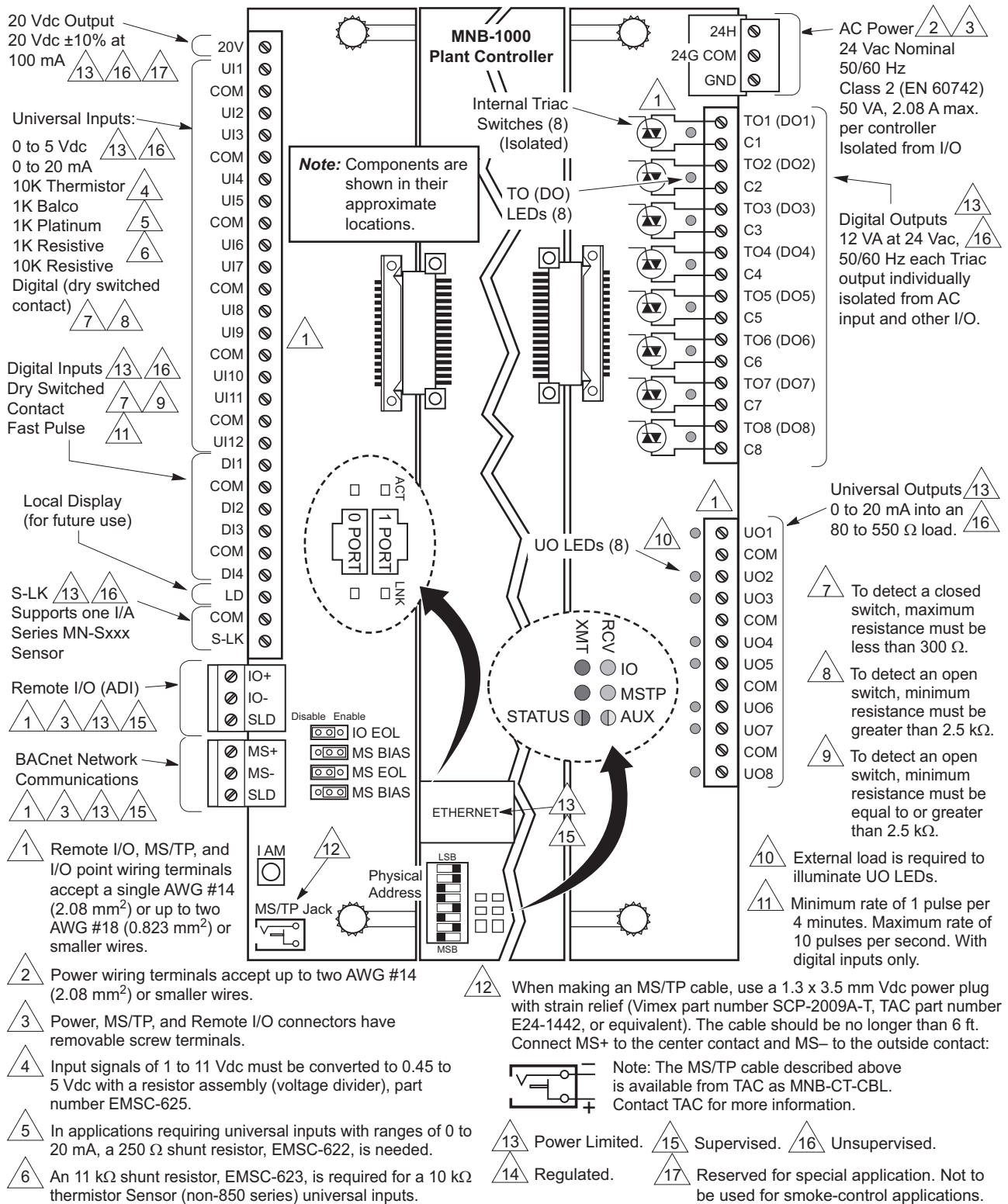

Figure-A.3 MNB-1000 Terminal Connections.

# Input and Output Specifications

All MicroNet BACnet controllers use input and output types as described in this section.

## Universal Inputs

The universal input characteristics are software-configured to respond to one of the eight input types listed in [Table–A.7](#).

**Table–A.7 Universal Inputs.**

Input	Characteristics
<b>10 kΩ Thermistor with 11 kΩ Shunt Resistor</b>	Sensor operating range -40 to 250 °F (-40 to 121 °C), requires Schneider Electric model TSMN-57011-850 series, TS-5700-850 series, or equivalent. Requires external 11 kΩ shunt resistor, EMSC-623.
<b>1 kΩ Balco</b>	-40 to 250 °F (-40 to 121 °C), Schneider Electric model TSMN-81011, TS-8000 series, or equivalent.
<b>1 kΩ Platinum</b>	-40 to 240 °F (-40 to 116 °C), Schneider Electric model TSMN-58011, TS-5800 series, or equivalent.
<b>1 kΩ Resistive</b>	0 to 1500 Ω.
<b>10 kΩ Resistive</b>	0 to 10.5 kΩ.
<b>Analog Voltage</b>	Range 0 to 5 Vdc
<b>Analog Current</b>	0 to 20 mA, requires external 250 Ω shunt resistor, EMSC-622.
<b>Digital</b>	Dry switched contact; detection of closed switch requires less than 300 Ω resistance; detection of open switch requires more than 2.5 kΩ.

See [Figure-A.4](#) for examples of connections to universal inputs.

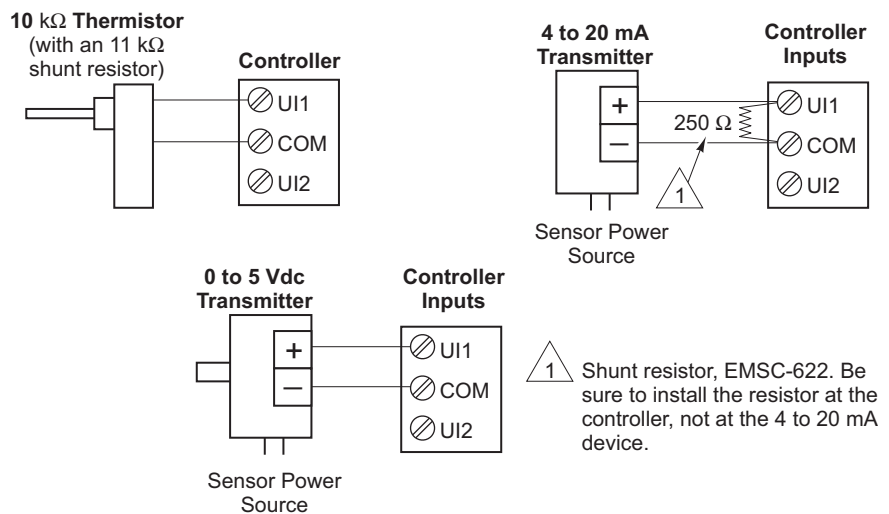

Figure–A.4 Universal Input Connections.

### Universal Outputs

0 to 20 mA (output load from 80 to 550 Ω). See Figure-A.5 for examples of connections to universal outputs.

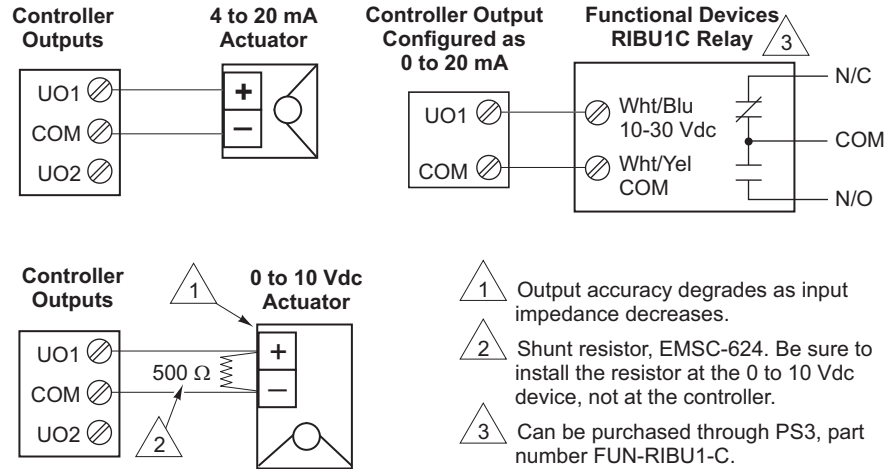

Figure-A.5 Universal Output Connections.

### Digital Inputs

Dry switched contact. Detection of a closed switch requires less than 300 Ω resistance. When connected to a controller’s digital inputs, detection of an open switch requires more than 2.5 kΩ. When connected to a controller’s universal inputs (used as digital inputs), detection of an open switch requires more than 2.5 kΩ. See Figure-A.6 for examples of a connection to digital inputs.

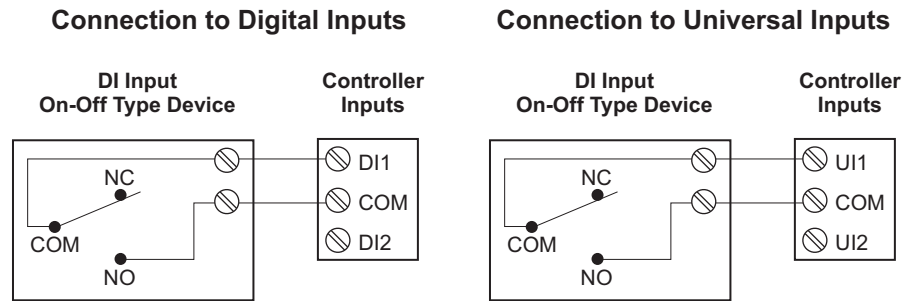

Figure-A.6 Digital Input Connections.

## Digital Outputs, Triac

### MNB-V2

Table–A.8 lists specifications for the Triac outputs featured on the MNB-V2 controller.

**Caution:** The Triac (digital) outputs on MicroNet BACnet controllers are not protected against short circuits. Take necessary precautions to protect these outputs against short circuits.

Table–A.8 Digital Outputs, Triac, on MNB-V2.

Input	Characteristics <sup>a</sup>
<b>Common Terminal</b>	Internally sourced, high side switching. Triac outputs share a common supply (24H) that is independently switched to each output terminal, SW24H1, SW24H2, and SW24H3 (DO1, DO2, and DO3).
<b>Rating (DO1+DO2)<sup>b</sup></b>	24 VA total at 24 Vac, 50/60 Hz.
<b>Rating (DO3)<sup>b</sup></b>	12 VA at 24 Vac, 50/60 Hz.
<b>Default Output State</b>	OFF (inactive).

- As with all Triac devices, a high-impedance meter on the output without a load will show 24 Vac, due to low level leakage through the device.
- As labeled on the controller, SW24H1=DO1, SW24H2=DO2, and SW24H3=DO3 (see Figure–A.2).

See Figure–A.7 for an example of a connection to an MNB-V2 controller's Triac outputs.

**Note:** All references to the MNB-V1 equally apply to the MNB-V1-2 and all references to the MNB-V2 equally apply to the MNB-V2-2.

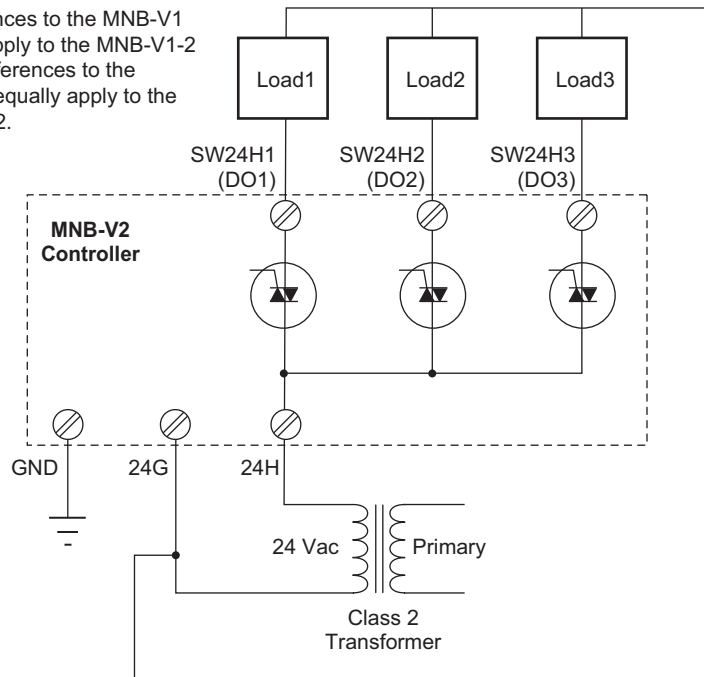

Figure–A.7 MNB-V2 Controller Triac Output Circuit Configuration.



**Note:** With the MNB-V2, AC voltage to Triacs is sourced from the controller. This is different from the MNB-300 and MNB-1000 controllers, where AC voltage is sourced externally.

**MNB-300 and MNB-1000**

Table–A.9 lists specifications for the Triac outputs featured on MNB-300 and MNB-1000 controllers.

**Caution:** The Triac (digital) outputs on MicroNet BACnet controllers are not protected against short circuits. Take necessary precautions to protect these outputs against short circuits.

**Table–A.9 Digital Outputs, Triac, on MNB-300 and MNB-1000.**

Input	Characteristics <sup>a</sup>
<b>Isolation</b>	Each output individually isolated from circuit common.
<b>Common Terminal</b>	Each TO has its own common terminal. This is the voltage switched to each TO output.
<b>Rating</b>	12 VA at 24 Vac, 50/60 Hz.
<b>Default Output State</b>	OFF (inactive).

a. As with all Triac devices, a high-impedance meter on the output without a load will show 24 Vac, due to low level leakage through the device.

See Figure-A.8 for an example of a connection to the Triac outputs on an MNB-300 or MNB-1000.

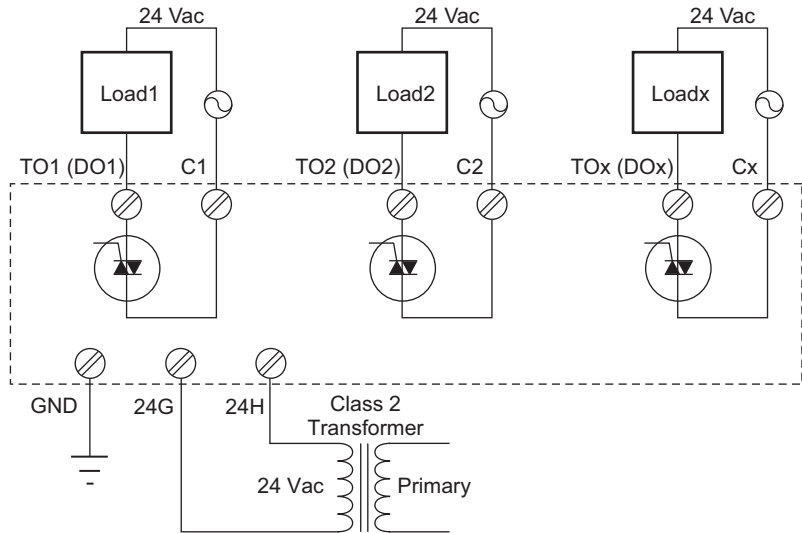

Figure–A.8 MNB-300 Controller and MNB-1000 Controller Triac Output Circuit Configuration.

## 20 Vdc Output

20 Vdc  $\pm$ 10% at 100 mA for supplying power to an external device. See [Figure-A.9](#) for an example of a connection to a 20 Vdc output.

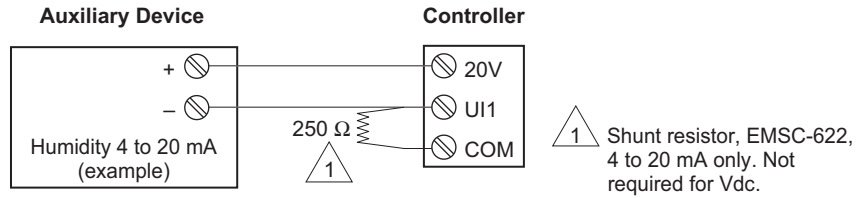

Figure-A.9 20 Vdc Output Connection.

## Inputs from MN-Sx MicroNet Sensor

[Table-A.10](#) lists specifications for the inputs from MicroNet Sensors. For an example showing how a MicroNet Sensor may be wired to a MicroNet BACnet controller, see [Figure-A.10](#).

Table-A.10 Inputs from MN-Sx MicroNet Sensor.

Input	Characteristics
Space Temperature	32 to 122 °F (0 to 50 °C).
Space Humidity	5 to 95% RH, non-condensing.
Local Setpoint	Adjustable within limits set by application programming tool.
Override Pushbutton	For standalone occupancy control.
Fan Operation and Speed Mode	On/off, speed (low/medium/high), or auto.
System Mode	Heat, cool, off, or auto.
Emergency Heat	Enable or disable.

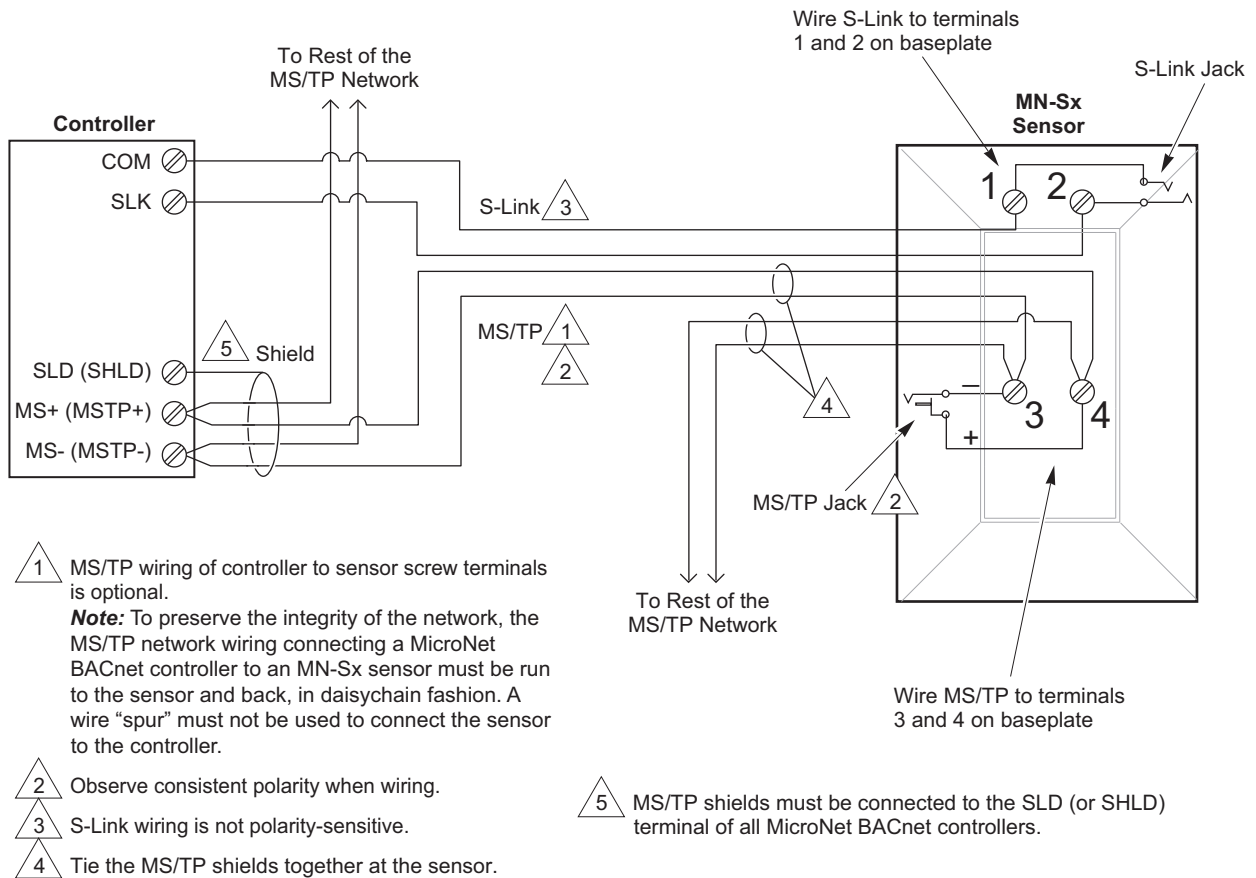

Figure–A.10 Sensor Link (S-Link) Connection.

## Velocity Pressure Input

### MNB-V1 and MNB-V2

Table–A.11 lists specifications for the velocity pressure inputs on MNB-Vx controllers.

Table–A.11 Velocity Pressure Input on MNB-V1 and MNB-V2.

Input	Characteristics
<b>Control Range</b>	0.004 to 1.5 in. of W.C. (0.996 to 373.5 Pa)
<b>Over Pressure Withstand</b>	±20 in. of W.C. (4.980 kPa)
<b>Accuracy</b>	±5% at 1.00 in. of W.C. (249.00 Pa) with laminar flow at 77 °F (25 °C) and suitable flow station.
<b>Sensor Type</b>	Self-calibrating flow sensor (differential pressure).
<b>Tubing Connections</b>	Barb fittings for 0.170 in. I.D. (4.3 mm I.D.) FRPE polyethylene tubing or 0.25 in. O.D./0.125 in. I.D. (6.4 mm O.D./3.2 mm I.D.) Tygon® tubing (high and low pressure taps).
<b>Tubing Length</b>	5 ft (1.52 m) maximum, each tube.

---

## Communication Circuits

Communications wiring includes a connection between the controller and a MicroNet MN-Sx Sensor via the S-Link, and a connection between the controller and the MicroNet BACnet Network. Optionally, an MS/TP jack on the MN-Sx sensor allows a PC with a network tool, such as WP Tech, to be connected to the BACnet network.

---

### **Caution:**

- Be sure to observe proper polarity when wiring the controller's MS/TP terminals to the MN-Sx Sensor's wall plate. See [Figure–A.10](#).
  - To preserve the integrity of the network, the MS/TP network wiring connecting a MicroNet BACnet controller to an MN-Sx sensor must be run to the sensor, then to the next controller, in daisy-chain fashion. A wire “spur” or “tee” must not be used to connect the sensor to the controller.
  - Communication wire pairs must be dedicated to MN-Sx (S-Link) and MicroNet BACnet network communications. They cannot be part of an active, bundled telephone trunk.
  - When wiring the MNB-300 or MNB-1000 controller, provide enough strain relief (slack) in the wires to allow full range of movement for the input and output boards.
  - Shielded cable is required for MS/TP network wiring and ADI wiring.
  - Shielded cable is not required for S-Link wiring.
  - If the cable is installed in areas of high RFI/EMI, the cable must be in conduit.
  - The cable's shield must be connected to earth ground at one end only. Shield must be continuous from one end of the trunk to the other.
- 

## Intermixing of Cables

Placing certain types of communications and power wiring in close proximity to each other can result in communications errors. To prevent this when running cables, you must note the combinations of wiring that may be intermixed and, when close placement is not recommended, ensure that there is sufficient separation between them. The combinations of wiring that are allowed to intermix are summarized in [Table–A.12](#).

---

### **Note:**

- The term, “intermix,” is used here to refer to the placement of wiring in close proximity to each other. The placing of wiring in the same conduit, or bundling the wiring together, are examples of extremely close placement.
  - Observe the correct shielding of cables to prevent communications problems such as those that may result from the intermixing of certain wiring types.
-

**Table–A.12 Allowed Wiring Combinations for Intermixing.**

Wiring	S-Link	MS/TP	ADI	UI, DI, UO	DO <sup>a</sup>	Class 2 24 Vac
<b>S-Link</b>	Yes	Yes	Yes	Yes	No	No
<b>MS/TP</b>	Yes	Yes	Yes	No	Yes	Yes
<b>ADI</b>	Yes	Yes	Yes	No	Yes	Yes
<b>UI, DI, UO</b>	Yes	No	No	Yes	No	No
<b>DO</b>	No	Yes	Yes	No	Yes	Yes
<b>Class 2 24 Vac</b>	No	Yes	Yes	No	Yes	Yes

a. MNB-V2 DO wiring, which is non-power limited, cannot be routed with any other device wiring that is power limited.

The following paragraphs detail the conditions under which wiring can be intermixed, including placement in the same conduit.

### Sensor Link (S-Link) Wiring

Observe the following when laying S-Link wiring.

---

**Note:** Refer to [Table–A.12](#) for a summary of the types of wiring that may be placed in close proximity to each other, such as when running wiring through a common conduit.

---

- Do not intermix S-Link wiring with DO wiring or Class 2 AC power wiring, especially in the same conduit.
- The S-Link wiring between an MN-Sx sensor and a MicroNet controller can be intermixed with the ADI wiring, or the MicroNet BACnet MS/TP wiring, including placement in the same conduit, so long as they are separate cables.
- S-Link wiring can be intermixed with UI, UO, and DI wiring, including its placement in the same conduit.

### MicroNet MS/TP Network Wiring

Observe the following when laying MicroNet MS/TP network wiring.

---

**Note:** Refer to [Table–A.12](#) for a summary of the types of wiring that may be placed in close proximity to each other, such as when running wiring through a common conduit.

---

- Do not intermix MS/TP wiring with UI, UO, or DI types of wiring.
- The MicroNet BACnet MS/TP wiring can be intermixed with the S-Link wiring between an MN-Sx sensor and a MicroNet controller, including placement in the same conduit, so long as they are separate cables.
- The MicroNet BACnet MS/TP wiring can be intermixed with ADI wiring or DO wiring, including placement in the same conduit, so long as they are separate cables.
- BACnet MS/TP network and Class 2 AC power wiring can be intermixed (including placement in the same conduit), provided they are separate cables, and the MS/TP wire is properly shielded and meets the requirements stated in "[Cable Specifications](#)" on page 17.

---

## ADI Wiring

Observe the following when laying ADI wiring.

---

**Note:** Refer to [Table–A.12](#) for a summary of the types of wiring that may be placed in close proximity to each other, such as when running wiring through a common conduit.

---

- Do not intermix ADI wiring with UI, UO, or DI types of wiring.
- The ADI wiring can be intermixed with the S-Link wiring between an MN-Sx sensor and a MicroNet controller, including placement in the same conduit, so long as they are separate cables.
- The ADI wiring can be intermixed with MicroNet BACnet MS/TP wiring or DO wiring, including placement in the same conduit, so long as they are separate cables.
- The ADI wiring and Class 2 AC power wiring can be intermixed (including placement in the same conduit), provided they are separate cables, and the ADI wire is properly shielded and meets the requirements stated in "[ADI Wiring Specifications](#)" on page 18.

## Ethernet Network Wiring

Observe the wire specifications listed in [Table–A.13](#) when selecting cable for Ethernet wiring in an I/A Series BACnet smoke-control system.

Table–A.13 Ethernet Cable Specifications.

Communication Speed	Wire Type	Description	Characeristic Impedance	Max. Length Between Devices
10 Mbit	24 AWG (0.205 mm <sup>2</sup> ) Solid Conductor	Unshielded Twisted Pair (UTP) 4-Pair, Category 3 Minimum	100 Ω	100 m (328 ft) Per Segment
100 Mbit		Unshielded Twisted Pair (UTP) 4-Pair, Category 5 Minimum (retrofit installations) Category 5e (new installations)		

## MicroNet MS/TP Network Wiring

---

### Caution:

- Before terminating the communications (MS/TP) wiring at the controller, test the wiring for the presence of a 24 Vac or 120 Vac voltage signal. If present, *do not* terminate the wiring at the controller's MS/TP terminals. Doing so will damage the transceiver chip, rendering the controller unable to communicate. Instead, take corrective action before terminating the controller.
- *Polarity must be observed* for all MS/TP wiring within the MicroNet BACnet network.
- The MS/TP cable's shield must be connected to earth ground (GND) at one end only, to prevent ground currents. Shield must be continuous from one end of the trunk to the other.
- To preserve the integrity of the network, the MS/TP network wiring connecting a MicroNet BACnet controller to an MN-Sx sensor must be run to the sensor, then to the next controller, in daisy-chain fashion. A wire "spur" or "tee" must not be used to connect the sensor to the controller.
- Refer to "[Intermixing of Cables](#)" on page 14 for a discussion of when

BACnet MS/TP network wiring may share conduit with other types of wiring.

### Cable Specifications

Low capacitance cable is required for high baud rates and high controller counts. For this reason, all new installations should use a low-capacitance cable.

**Note:** Low-capacitance cables are not available in wire sizes larger than 22 AWG (0.326 mm<sup>2</sup>).

Cable for wiring an I/A Series MS/TP network shall meet the following specifications:

- Use shielded, twisted-pair cable with characteristic impedance between 100 and 130 Ω. The shield may be either a foil- or braid-type, and should shield a single pair of conductors.
- Distributed capacitance between conductors shall be less than 15 pF/ft (49 pF/m).
- Distributed capacitance between the conductors and the shield shall be less than 30 pF/ft (98 pF/m).
- The maximum recommended length of an MS/TP segment is 4000 ft (1200 m), using the cables listed in [Table A.14, on page 17](#).

### Approved Cable Types

The stranded, twisted-pair cables listed in [Table–A.14](#) are recommended for wiring a MicroNet BACnet MS/TP network.

**Note:** Although the cables listed in [Table–A.14](#) are recommended, other cables meeting the same specifications may be used, instead.

**Table–A.14 Recommended BACnet MS/TP Cable Types.**

Baud Rate	No. of Devices <sup>a</sup>	Cable	AWG (mm <sup>2</sup> )	Plenum-Rated <sup>b</sup>	Electrical Specifications			
					Capacitance @1 kHz		Cond. DC Resis. per 1000 ft	Oper. Temp.
					Cond-Cond	Cond-Shield		
19,200 or Less	32 Devices or Less	Belden 8641	24 (0.205)	No	22.0 pF/ft (73 pF/m)	42.0 pF/ft (140 pF/m)	25 Ω	-4 to +176 °F (-20 to +80 °C)
		Belden 82641	24 (0.205)	Yes	31.0 pF/ft (103 pF/m)	59.0 pF/ft (197 pF/m)	24 Ω	+32 to +140 °F (-0 to +60 °C)
		Belden 82502	24 (0.205)	Yes	25.0 pF/ft (83 pF/m)	45.0 pF/ft (150 pF/m)	24 Ω	+32 to +140 °F (-0 to +60 °C)
76,800 or Less	128 Devices or Less	Connect-Air W241P-2000F	24 (0.205)	Yes	11.4 pF/ft (38 pF/m)	n/a	27 Ω	+302 °F max. (+150 °C max.)
		Connect-Air W241P-2000S						
		Belden 89841	24 (0.205)	Yes	12.0 pF/ft (40 pF/m)	22.0 pF/ft (73 pF/m)	24 Ω	-94 to +392 °F (-70 to +200 °C)

a. The length of a wiring segment must be 4000 ft (1200 m) or less.

b. Use plenum-rated cable for operating temperatures less than -4 °F (-20 °C).

---

## Signaling Line Circuits

### ADI Wiring Specifications

Wiring for an ADI panel shall meet the following specifications:

- Use shielded, twisted-pair cable with characteristic impedance between 100 and 130  $\Omega$ .
- Distributed capacitance between conductors shall be less than 15 pF/ft (49 pF/m).
- Distributed capacitance between the conductors and the shield shall be less than 30 pF/ft (98 pF/m).
- Foil or braided shields are acceptable.
- The maximum recommended length of an ADI wiring segment is 4000 ft (1200 m), using the cables listed for “76,800 or Less” baud rate in [Table A.14, on page 17](#).

---

**Caution:** Observe the following requirements for wiring between an MNB-1000 and an ADI panel.

- Before terminating the wiring at the controller, test the wiring for the presence of a 24 Vac or 120 Vac voltage signal. If present, *do not* terminate the wiring at the controller’s terminals used for the ADI panel. Doing so will damage the transceiver chip, rendering the controller unable to communicate. Instead, take corrective action before terminating the controller.
  - *Polarity must be observed.*
  - The cable’s shield must be connected to earth ground (GND) at one end only, to prevent ground currents. Shield must be continuous from one end of the trunk to the other.
  - Refer to "[Intermixing of Cables](#)" on page 14 for a discussion of when ADI wiring may share conduit with other types of wiring.
-



## I/O Wiring

### Intermixing of Wiring

Observe the following when laying I/O wiring.

**Note:** Refer to [Table–A.12](#) for a summary of the types of wiring that may be placed in close proximity to each other, such as when running wiring through a common conduit.

- Do not intermix UI, UO, or DI wiring with BACnet MS/TP wiring, ADI wiring, DO wiring, or Class 2 AC power wiring, especially placement in the same conduit.
- UI, UO, DI, and S-Link wiring can be intermixed, including placement in the same conduit, so long as they are separate cables.
- Do not intermix DO wiring with S-Link wiring, especially placement in the same conduit.
- DO wiring can be intermixed with BACnet MS/TP wiring, ADI wiring, or Class 2 AC power wiring, including placement in the same conduit, so long as they are separate cables.

I/O connections include universal inputs, universal outputs, digital inputs, and digital outputs. See [Figure–A.1](#), [Figure–A.2](#), and [Figure–A.3](#) for wire terminal information.

**Caution:** If shielded cable is used, connect only one end of the shield to the common terminal at the controller.

### Universal Inputs (UI), Universal Outputs (UO), and Digital Inputs (DI)

**Caution:** Input and output devices cannot share common wiring. Each connected device requires a separate signal and return conductor.

**Note:** If maximum closed switch voltage is not more than 1.0 V and minimum open switch voltage is at least 4.5 V, then solid state switches may be used for a UI or a DI.

UI, UO, and DI wiring needs at least AWG #24 (0.205 mm<sup>2</sup>), twisted pair, voice grade telephone wire. The capacitance between conductors cannot be more than 32 pF per foot (0.3 m). If shielded cable is used, the capacitance between any one conductor and the others, connected to the shield, cannot be more than 60 pF per foot (0.3 m). [Table–A.15](#) provides wiring specifications.

**Table–A.15 UI, UO, and DI Wiring Specifications.**

Connection	Gauge AWG (mm <sup>2</sup> )	Maximum Distance ft (m)
UI, UO, and DI	18 (0.823)	300 (91)
	20 (0.518)	200 (61)
	22 (0.326)	125 (38)
	24 (0.205)	75 (23)

Refer to [Figure–A.4](#), [Figure–A.5](#), and [Figure–A.6](#), respectively, for examples of UI, UO, and DI connections.

---

## Power Supply Wiring

Ensure that MNB-300, MNB-Vx, and MNB-1000 controllers have appropriate 24 Vac power. Take note of the following cautions when providing power to these controllers.

---

**Caution:**

- **Very important!** *When powering multiple Class 2 devices from the same Class 2 power transformer, polarity must be observed (24H connected to 24H, and 24G connected to 24G).*
- MicroNet BACnet controllers are Class 2-only devices, and must be connected to a Class 2 source. Class 2 circuits must not intermix with Class 1 circuits.
- The MNB-300 and MNB-Vx controllers contain a non-isolated *half-wave* rectifier power supply and must not be powered by transformers used to power other devices containing non-isolated *full-wave* rectifier power supplies. Note that this precaution *does not apply to the MNB-1000*, whose IO are fully isolated from its power supply input. Therefore, an MNB-1000 *can be powered* with the same transformer used to power MNB-300 and MNB-Vx controllers. Refer to *EN-206, Guidelines for Powering Multiple Devices from a Common Transformer*, F-26363, for detailed information.
- Use a Class 2 power transformer supplying a nominal 24 Vac, sized appropriately for the controller (16 VA for MNB-300, 15 VA for MNB-Vx, and 50 VA for MNB-1000) plus the anticipated DO loads. The supply to the transformer must be provided with a breaker or disconnect. In European Community, the transformer must conform to EN 60742.
- The Class 2 power transformer may be used to power multiple Class 2 powered devices, provided that the transformer is properly sized to power all equipment simultaneously and all devices contain the same type of rectifier power supplies or internal isolation.
- The transformer frame must be grounded.
- Do not intermix Class 2 AC power wiring with S-Link wiring or UI, UO, or DI wiring, especially placement in the same conduit.
- Class 2 AC power wiring can be intermixed with BACnet MS/TP wiring, ADI wiring, or DO wiring, including placement in the same conduit, so long as they are separate cables.
- Refer to [Table–A.12](#) for a summary of the types of wiring that may be placed in close proximity to each other, such as when running wiring through a common conduit.

---

Where power is derived from a central transformer, ensure that the transformer is appropriately sized for the required VA, with adequate margin, and that the power wiring length is minimized and the appropriate wire size is utilized to minimize line drops. Adequate transformer power margin should be allowed so that fluctuations of the primary transformer voltage or fluctuations in the secondary loads do not cause low voltage power conditions as seen at the 24 Vac input to the controllers.

The MNB-xxxx series controllers contain circuitry that is designed to protect the integrity of the embedded flash memory under low-voltage or questionable input voltage conditions. In the event of a controller-perceived

low-voltage condition, the controller will set a read-only flag and lock out all writes to memory, as well as turn off controller outputs. The read-only flag can be easily viewed from the WorkPlace Commissioning Tool (WPCT) under the “Device Properties” and will indicate the controller status as “Operational, Read-Only.” The Read-Only status can help serve as an indicator that the input voltage to the controller may be questionable.

Attention should also be paid to the wire distance between the central transformer and the secondary loads, especially in the case of half-wave input devices like the MNB-Vx series and MNB-300 controllers. With half-wave type input devices, significant AC input current spikes can occur during the positive half-cycle of the AC input. Large resistances due to the wire lengths can cause significant voltage drops as seen from the controller AC input. In extreme cases, the controller may enter the read-only mode at apparent AC voltages exceeding 20 Vac due to the asymmetrical nature of the AC input voltage waveforms. In these cases, reducing the load on the transformer, reducing the wire length between the controller and the transformer, and using higher current rated wire will correct the problem.

**Note:**

- Power wiring terminals accept one AWG #14 (2.08 mm<sup>2</sup>) or up to two AWG #18 (0.823 mm<sup>2</sup>) wires.
- Power wiring can be intermixed with DO wiring.
- Twisted or untwisted cable can be used for power wiring.
- To preserve the integrity of the network, the MS/TP network wiring connecting a MicroNet BACnet controller to an MN-Sx sensor must be run to the sensor and back, in daisychain fashion. A wire “spur” must not be used to connect the sensor to the controller.

Figure–A.11 and Figure–A.12 are acceptable wiring configurations.

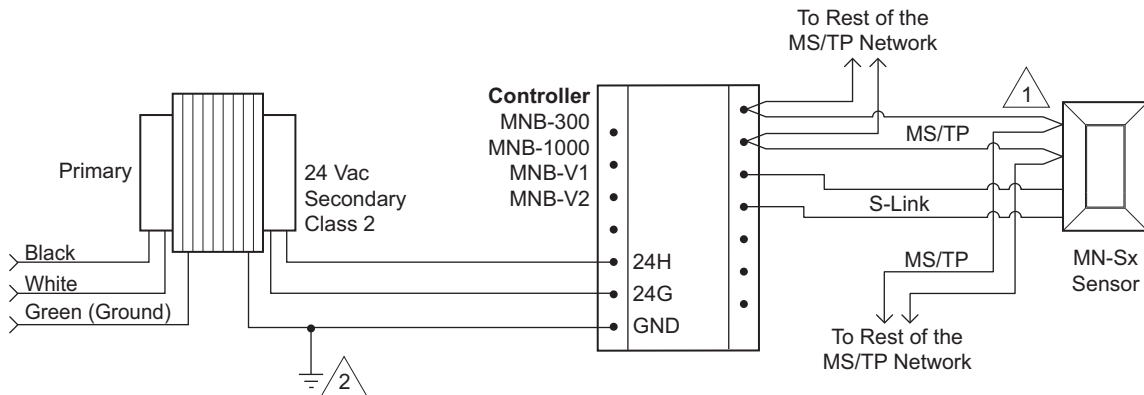

- 1 Optional connection provides local access to the MS/TP network.
- 2 Ground the frame of the transformer to a known ground.

**Note:** All references to the MNB-V1 equally apply to the MNB-V1-2 and all references to the MNB-V2 equally apply to the MNB-V2-2.

Figure–A.11 Single Controller or I/O Module Powered from a Separate Class 2 Power Source.

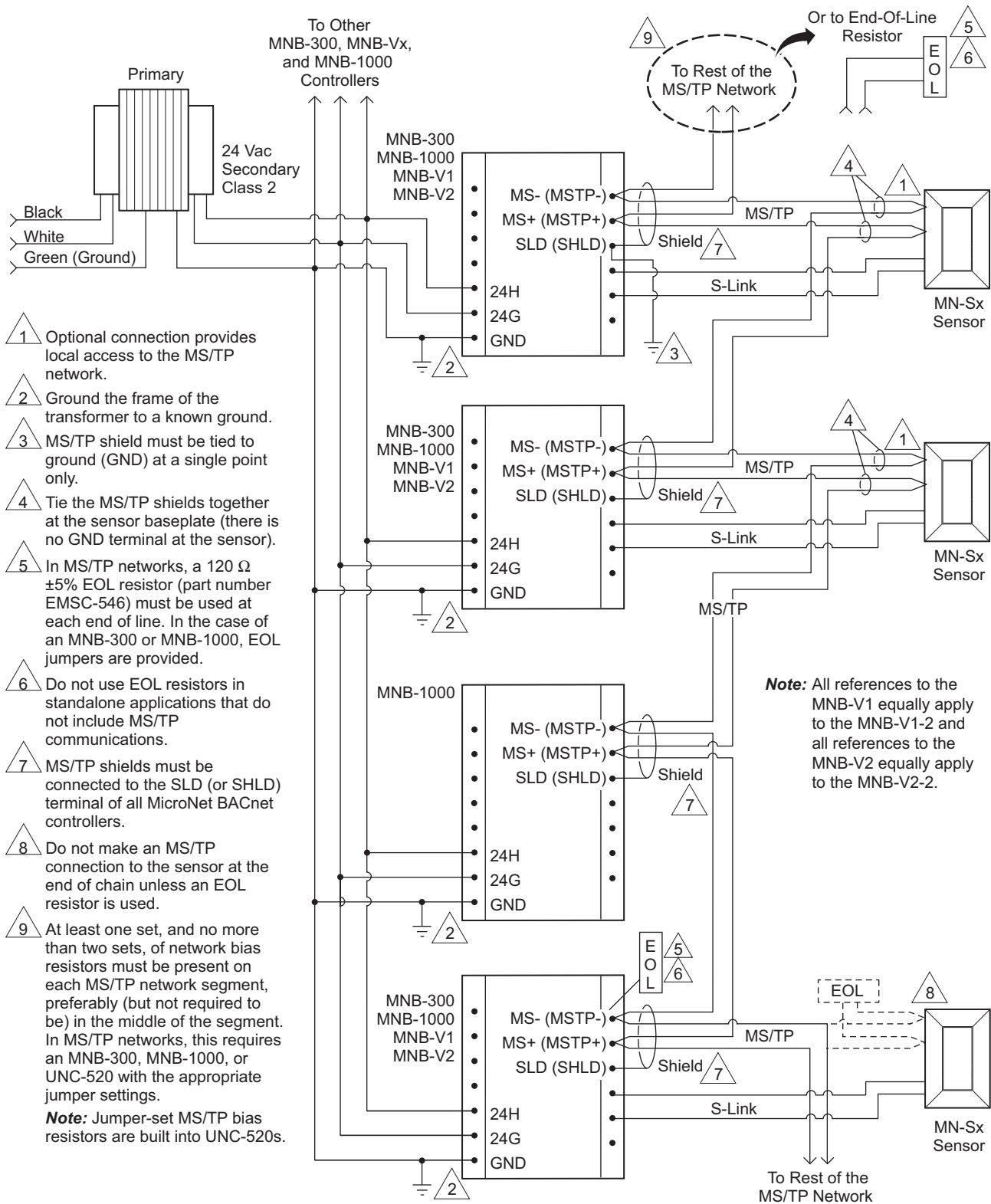

Figure—A.12 Multiple Controllers Powered from a Single Class 2 Power Source and Sharing Communications in a BACnet MS/TP Segment.

---

# **Appendix B**

## **Approved Part Numbers**

This appendix lists all I/A Series MicroNet BACnet equipment part numbers that have been UL 864 UUKL/UUKL7 Listed. Only those part numbers listed in this appendix are approved for use in smoke-control applications. All Listed assemblies with a final assembly part number carry the system listing mark. All Listed subassemblies with a subassembly part number and all Listed accessories carry the subassembly listing mark.

### **Controllers**

#### **Final Assemblies**

**Table 1:**

MNB-V1	MicroNet BACnet VAV Cooling Only Controller
MNB-V1-2	MicroNet BACnet VAV Cooling Only Controller
MNB-V2	MicroNet BACnet VAV Controller
MNB-V2-2	MicroNet BACnet VAV Controller
MNB-300	MicroNet BACnet Unitary Controller
MNB-1000	MicroNet BACnet Plant Controller

#### **Subassemblies**

**Table 2:**

MNB-V1-500	MNB-V1 Controller PCB
MNB-V2-500	MNB-V2 Controller PCB
MNB-FLO-751	MNB-Vx Actuator Assembly

**Table 2: (Continued)**

MNB-CNTRLR-300	MNB-300 Cover and Main PCB Assembly
MNB-BASE-300	MNB-300 Mounting Base with I/O Terminal PCBs
MNB-CNTRLR-1000	MNB-1000 Cover with Main PCB Assembly
MNB-BASE-1000	MNB-1000 Mounting Base with I/O Terminal PCBs

## Transformers

### Final Assembly

**Note:**

- The EMSC-541, EMSC-542, and EMSC-543 are not approved for use in smoke control applications in Canada, as covered in ULC Standard ULC-S527-99.
- These transformers are approved for use with I/A Series BACnet UUKL systems, but are not UL 864 UUKL/UUKL7 Listed.

**Table 3:**

EMSC-541	Transformer, 50 VA, 120V Pri., 24V Sec., 50/60 HZ, Fused (nonreplaceable) Primary Approx. 5.5" x 4.0" x 3.5"H
EMSC-542	Transformer, 100 VA, 120V Pri., 24V Sec., 50/60 HZ, Fused (nonreplaceable) Primary Approx. 6.0" x 4.0" x 3.5"H
EMSC-543	Transformer, 240 VA, 120V Pri., 24V Sec., 60 HZ, Fused (nonreplaceable) Primary Approx. 4.5" x 4.75" x 3.75"H
EMSC-583	Transformer, 75 VA, 120 V Pri., 24 V Sec., 50/60 Hz, Class 2, 2.5" x 4.5" x 3.0", Conduit Fitting
EMSC-616	Transformer, 75 VA, 120 V Pri., 24 V Sec., 50/60 Hz, Class 2, Foot Mount Single Hub UL Listed w/Circuit Breaker, Mounting Plate Included
EMSC-618	Transformer 96 VA, 120 V Pri., 24 V Sec., 50/60 Hz, Class 2, Foot Mount Single Hub UL Listed w/Circuit Breaker, Mounting Plate Included

## Accessories

### Subassemblies

**Table 4:**

EMSC-546	MS/TP (EIA-485) Termination Resistor (EOL), 120 $\Omega$ , with 8 in. (nominal) Leads of 18 AWG Gray Wire
EMSC-621	Transient Suppressor Assembly, with Two 6 in. (nominal) Leads of 18 AWG Gray Wire and One 6 in. (nominal) Lead of 18 AWG Green Wire
EMSC-622	250 $\Omega$ Shunt Resistor, with two 8 in. (nominal) Leads of 18 AWG White Wire
EMSC-623	11 k $\Omega$ Shunt Resistor, with two 8 in. (nominal) Leads of 18 AWG White Wire
EMSC-624	500 $\Omega$ Shunt Resistor, with two 8 in. (nominal) Leads of 18 AWG White Wire
EMSC-625	Resistor Assembly (Voltage Divider), with one 9 in. (nominal) Lead of 18 AWG Gray Wire, one 9 in. (nominal) Lead of 18 AWG Blue Wire, and one 9 in. (nominal) Lead of 18 AWG Yellow Wire

## Enclosures

**Table 5:**

MNA-FLO-1	Plenum Mount Metal Enclosure for MNB-V1 and MNB-V2 Controllers
MNB-300-ENC	Wall Mount Enclosure for MNB-300
MNB-1000-ENC	Wall Mount Enclosure for MNB-1000

---

## Third Party UUKL Listed Products

**Table 6:**

EIS8-100T	Contemporary Control Systems, Inc. 8-port 10BaseT/100BaseTX, Eight RJ-45 Ports, 8-24 Vac, 5 VA
EIS6-100T/FT	Contemporary Control Systems, Inc. 4-port 100BaseTX/2-port 100BaseFX Multimode, Four RJ-45 Ports and Two ST Fiber Optic 1300 nm Ports, 8-24 Vac, 5 VA
B-LINK-AC-S	Andover Controls MS/TP Repeater, 115/230 Vac, 6 VA
B-LINK-F-AC-S	Andover Controls MS/TP Repeater, Fiber, 115/230 Vac, 6 VA
INV-xxxxx Model Series	Automation Displays, Inc. Firefighter's Smoke Control Station



---

# ***Appendix C***

## ***Applicable Documentation***

This appendix lists, by F-number, all applicable documentation that is required to install, apply, engineer, operate, and troubleshoot I//A Series MicroNet BACnet and related equipment.

### **Installation Instructions**

**Table 7:**

F-26363	EN-206 Guidelines for Powering Multiple Devices from a Common Transformer
F-27345	MicroNet BACnet MNB-300 Unitary Controller Installation Instructions
F-27346	MicroNet BACnet MNB-V1, MNB-V2 VAV Controllers Installation Instructions
F-27347	MicroNet BACnet MNB-1000 Plant Controller Installation Instructions
F-26277	I/A Series MicroNet Sensors MN-SX, MN-SXHT, MN-S4-FCS, and MN-S4HT-FCS General Instructions
F-27367	I/A Series WorkPlace Tech Tool 5.X Installation Instructions
F-27381	BACnet MS/TP Adapter Cable Installation Instructions

---

## Manuals

**Table 8:**

F-27254	WorkPlace Tech Tool 4.0 Engineering Guide
F-27255	WorkPlace Tech Tool 4.0 Users Guide
F-27356	WorkPlace Tech Tool 5.7 Engineering Guide Supplement
F-27358	TAC I/A Series MicroNet BACnet WorkPlace Commissioning Tool and Flow Balance Tool Users Guide
F-27360	TAC I/A Series MicroNet BACnet Wiring, Networking, and Best Practices Guide

## Release Notes

**Table 9:**

F-27526	WorkPlace Tech 5.7.x Release Notes/Getting Started
---------	--

---

# Appendix D

## References

### Other Reference Publications

National Fire Protection Association, Inc. Technical Correlating Committee on National Electrical Code. NFPA 70 National Electrical Code. 2008 ed. Available from National Fire Protection Association, Batterymarch Park, Quincy, MA.

National Fire Protection Association, Inc. Technical Committee on Signaling Systems for the Protection of Life and Property. NFPA 72 National Fire Alarm Code. 2007 ed. Available from National Fire Protection Association, Batterymarch Park, Quincy, MA.

National Fire Protection Association, Inc. Technical Committee on Smoke Management Systems. NFPA 92A *Standard for Smoke-Control Systems Utilizing Barriers and Pressure Differences*. 2009 ed. Available from National Fire Protection Association, Batterymarch Park, Quincy, MA.

National Fire Protection Association, Inc. Technical Committee on Smoke Management Systems. NFPA 92B *Guide for Smoke Management Systems in Malls, Atria, and Large Areas*. 2000 ed. Available from National Fire Protection Association, Batterymarch Park, Quincy, MA.

Underwriters Laboratories, Inc. *UL Online Certifications Directory*, UUKL Guide Info Smoke-Control System Equipment  
To view online:  
Navigate your Web browser to <http://www.ul.com> and then, in the navigation pane, click the link to the Certifications page. On the Certifications page, click the link, **Certifications Directory** or **Online Certifications Directory**. When the Online Certifications Directory page opens, type “uukl” in the UL Category Code field and “guideinfo” in the Keyword field of the BEGIN A BASIC SEARCH form, and then click **SEARCH**. In the Search results list, click the link, **UUKL.GuidelInfo**, in the Link to File column.

---

Underwriters Laboratories, Inc. *UL Online Certifications Directory*,  
UUKL S5381 Smoke-Control System Equipment

To view online, use one of the following paths:

Option 1—Open the Web page, UUKL Guide Info Smoke-Control System Equipment (see above). On this page, click the link, **View Listings**. In the resulting list, find “TAC L L C” and then click the link, **UUKL.S5381**, in the Link to File column.

Option 2—Open the *UL Online Certifications Directory* Web page (see above). In the BEGIN A BASIC SEARCH form, type “TAC, L L C” in the Company Name field, making sure that you include a space between each of the letters in “L L C,” and then click **SEARCH**. In the resulting list, search for “Smoke-control System Equipment” and then click the link, **UUKL.S5381**, in the Link to File column.

Underwriters Laboratories, Inc. UL 864, *Control Units and Accessories for Fire Alarm Systems*, 9th ed., 2003

Available from Underwriters Laboratories, Northbrook, IL.

Underwriters Laboratories of Canada (ULC), CAN/ULC-S527-99, *Standard for Control Units for Fire Alarm Systems*, 2nd ed., 1999

Available from Underwriters Laboratories of Canada, Toronto, Ontario, Canada.

---

**Note:** UUKL7, which is referred to throughout this manual, is the Category Code Number (CCN) for smoke-control system equipment certified for use in Canada.

---







---

On October 1st, 2009, TAC became the Buildings Business of its parent company Schneider Electric. This document reflects the visual identity of Schneider Electric, however there remains references to TAC as a corporate brand in the body copy. As each document is updated, the body copy will be changed to reflect appropriate corporate brand changes.

All brand names, trademarks and registered trademarks are the property of their respective owners. Information contained within this document is subject to change without notice.

**Schneider Electric** 1354 Clifford Avenue, P.O. Box 2940, Loves Park, IL 61132-2940, USA 1-888-444-1311 [www.schneider-electric.com/buildings](http://www.schneider-electric.com/buildings)

F-27419-2

September 2010 ptm

© 2010 Schneider Electric. All rights reserved.

