

MicroNet VAV Series Controllers



SPECIFICATIONS

HARDWARE

Dimensions

7-3/4 H x 6-1/4 W x 2-1/2 D in (197 x 159 x 63 mm).

Enclosure

Conforms to NEMA-1 requirements.

Meets UL94-5V flammability for plenum application use.

Conduit Knockouts

Not applicable. Order optional MicroNet Enclosure, MNA-FLO-1, if wiring to flexible conduit is desired.

Power Supply Input

20.4 to 30 Vac, 50/60 Hz.

MAXIMUM POWER CONSUMPTION

MNL-V1RVx

Maximum 12 VA.

MNL-V2RVx

Maximum 84 VA (12 VA plus DO loads @ 24 VA each).

Surge Immunity Compliance

ANSI C62.41 (IEEE-587, Category A & B).

AGENCY LISTINGS

FCC

Class B.

UL

UL-916 (File # E71385 Category PAZX).

UL Listed to Canadian Safety Standards (CAN/CSA C22.2).

EUROPEAN COMMUNITY – EMC DIRECTIVE 89/336/EEC

EN61326

MicroNet VAV Controllers MNB-Vx

The TAC I/A Series MicroNet™ VAV (Variable Air Volume) Controllers are interoperable controllers designed in accordance with LONMARK® guidelines. When programmed using WorkPlace Tech Tool or loaded with a pre-engineered application, they provide a wide range of control strategies for pressure independent terminal boxes with, or without, reheat capabilities. Both models provide an integral actuator with manual override, an integral patented pressure transducer, one digital input, one universal input, Sensor Link (S-Link) support, LED indication, and over-the-shaft damper mounting. In addition, the MNL-V2RVx model provides one analog output and three digital outputs. These controllers can function either in a standalone mode or as part of a LONWORKS® FTT-10 Free Topology communications network.

The VAV series controllers offer the advantages of standalone or networked control. Using a TAC I/A Series MicroNet Sensor (MN-Sx series), the operator can monitor controller performance and edit operational values. The WorkPlace Tech Tool software is used to program the controllers or download applications from the application library.

AMBIENT LIMITS

Operating Temperature

32 to 131 °F (0 to 55 °C).

Shipping and Storage Temperature

-40 to 160 °F (-40 to 71 °C).

Humidity

5 to 95% non-condensing.

Wiring Terminals

Screw terminals. Single AWG #14 (2.08 mm²) wire. Up to two AWG #18 (0.823 mm²) or smaller wires.

VELOCITY PRESSURE INPUT

Operating Range

0.0 to 2.5 in. of W.C. (0.0 to 0.622 kPa).

Control Range

0.05 to 2.00 in. of W.C. (0.0125 to 0.498 kPa).

Accuracy

± 5% @ 1.00 in. of W.C. (0.249 kPa) with Laminar flow @ 77 °F (25 °C) and suitable flow station.

Sensor Type

Self-calibrating flow sensor (differential pressure).

Continued on next page.

Continued from first page.

Tubing Connections

Barb fittings for 0.170" I.D. FRPE polyethylene tubing or 1/4" O.D./0.125" I.D. tygon tubing (high and low pressure taps).

Tubing Length

5 ft. (1.52 m) maximum each tube.

ACTUATOR OUTPUT

Torque Rating

53 lb-in. (6 N-m).

Stroke

Fully adjustable from 0° to 90°.

Timing

Approximately 3 minutes at 60 Hz (3.6 minutes at 50 Hz) for 90° rotation @ 24 Vac.

Position Indication

Provides a visual indication of position.

Manual Override

Pushbutton to allow manual positioning of the damper.

Damper Linkage

1/2" (12.75 mm) or 3/8" (9.5 mm) diameter round shaft extending 7/8" (22.23 mm) minimum from terminal box. 3/8" (9.5 mm) diameter shaft requires AM-135 adapter kit.

DIGITAL (RELAY) OUTPUTS (MNL-V2RVX)

SW24H1, SW24H2, and SW24H3 Current Ratings

24 VA each at 24 Vac, 50/60 Hz. Form A Single Pole Single Throw (SPST). Normally open. 300K cycles at 24 Vac, 24 VA (0.4 power factor).

Digital Input

Dry Contact. Detection of closed switch requires less than 300 ohms. Detection of open switch requires more than 100K ohm.

UNIVERSAL INPUT

1K ohm Balco Input

-40 to 250 °F (-40 to 121 °C) range.

1K ohm Platinum Input

-40 to 240 °F (-40 to 116 °C) range. TSMN-58011, TS-5800 Series or equivalent.

1K ohm Resistance

0 to 1.5K ohm.

10K ohm Thermistor w/ 11K ohm Shunt Resistor

-40 to 250 °F (-40 to 121 °C) range. TSMN-57011-850, TS-5700-850 Series or equivalent.

10K W Resistance

0 to 10.5K ohm.

Voltage

0 to 5 Vdc.

Current

0 to 20 mA requires an external 250 ohm shunt resistor.

Digital Input

Dry Contact. Detection of closed switch requires less than 300 W resistance. Detection of open switch requires more than 1.5K ohm.

ANALOG OUTPUT (MNL-V2RVX)

Current

0 to 20 mA (output load from 80 to 550 ohm).

INPUTS FROM MN-SX TAC I/A SERIES MICRONET SENSOR

Inputs	Description	MN-Sx Sensor
Space Temperature	32 to 122 °F (0 to 50 °C)	MN-S1, MN-S1HT, MN-S2, MN-S2HT, MN-S3, MN-S3HT, MN-S4, MN-S4HT, MN-S4-FCS, MN-S4HT-FCS, MN-S5 and MN-S5HT
Space Humidity	5 to 95% RH, Non-condensing	MN-S1HT, MN-S2HT, MN-S3HT, MN-S4HT, MN-S4HT-FCS, and MN-S5HT
Adjustable Setpoint	40 to 95 °F (4 to 35°C)	MN-S3, MN-S3HT, MN-S4, MN-S4HT, MN-S4-FCS, MN-S4HT-FCS, MN-S5, and MN-S5HT
Override Pushbutton	For standalone occupancy control or remote status monitoring of local status condition.	MN-S2, MN-S2HT, MN-S3, MN-S3HT, MN-S4, MN-S4HT, MN-S5, and MN-S5HT
Fan Operation and Speed	Fan mode selection: On, Speed (Low/Medium/High), or Auto.	MN-S4, MN-S4HT, MN-S4-FCS, MN-S4HT-FCS, MN-S5, and MN-S5HT
System Mode	System mode selection: Heat, Cool, Off, or Auto.	MN-S4, MN-S4HT, MN-S5, and MN-S5HT
Emergency Heat	Emergency heat mode selection: Enable or Disable	MN-S5 and MN-S5HT

MODELS

Part Number	Inputs and Outputs			
	Digital Inputs	Digital Outputs	Universal Inputs	Analog Outputs
MNL-V1RVx ^a	1	0	1	0
MNL-V2RVx ^a	1	3	1	1

CONTROL STRATEGIES

Model	Box Configuration	Reheat Type	Other
MNL-V1RVxa	Cooling	None	None
MNL-V2RVxa	Cooling Series Fan Induction Parallel Fan	Staged Electric Reheat Floating/Proportional Hydronic Reheat Time Proportioned	Occupancy Satellite ^b

a V denotes LONMARK VAV (Variable Air Volume) profile. "x" denotes profile version.

b Available control strategies depend on controller I/O.

FEATURES

Designed for new or existing systems, the VAV series controllers may be applied to pressure independent terminal boxes with, or without, reheat capabilities. The VAV series controllers offer the following types of Box Configuration and Reheat control strategies:

- Cooling.
- Series Fan.
- Parallel Fan.
- Induction.
- Staged Electric Reheat.
- Floating/Proportional Hydronic Reheat.
- Time Proportioned.
- Capability to function in standalone mode or as part of a LONWORKS FTT-10 Free Topology communications network.
- Integrated packaging with actuator, pressure transducer, and controller.
- Patented pressure transducer for years of reliable, accurate air flow readings.
- Integral actuator with manual override and travel limit settings for easy set up and support.
- Proportional (P), Proportional Plus Integral (PI), and Proportional Plus Integral and Derivative (PID) control for cooling and heating.
- Both controller models have plenum-rated enclosures.
- Air balancing using the TAC I/A Series MicroNet VAV Flow Balance software.
- Conforms to the LONMARK VAV controller profile.

Software Capabilities

- Conforms to the LONMARK guidelines.
- WorkPlace Tech Tool is capable of reconfiguring and editing application configuration data to fit a wide range of variable air volume control requirements.

- HVAC interoperability achieved through use of LONMARK HVAC profiles.
- Air balancing provided by the TAC I/A Series MicroNet VAV Flow Balance software.

TAC I/A Series MicroNet VAV FLOW Balance Software

Provides flow balancing for networked and standalone VAV series controllers. Features include:

- Local network control.
- Damper and fan adjustment.
- Setpoint monitoring and adjustment.
- Flow validation and calibration.
- Sequence, calibration, and control setpoint logs.

COMMUNICATIONS

LONWORKS Networks

LONWORKS communications network uses an FTT-10 Free Topology configuration. Controllers on a LONWORKS network can communicate with each other in a peer-to-peer fashion. A LONWORKS network has a communications speed of 78k baud, using unshielded, twisted-pair cabling, with connections that are not polarity sensitive.

S-Link

The Sensor Link (S-Link) communications wiring provides power and a communication interface for an MN-Sx TAC I/A Series MicroNet sensor. The various MN-Sx sensors can provide room temperature, room humidity, setpoint adjustment, and occupancy override. This connection uses two-wire, unshielded cable and is not polarity sensitive. Maximum wire length allowed between a controller and a TAC I/A Series MicroNet Sensor is 200 ft (61 m).

TAC I/A SERIES MICRONET VAV CONTROLLER ARCHITECTURE

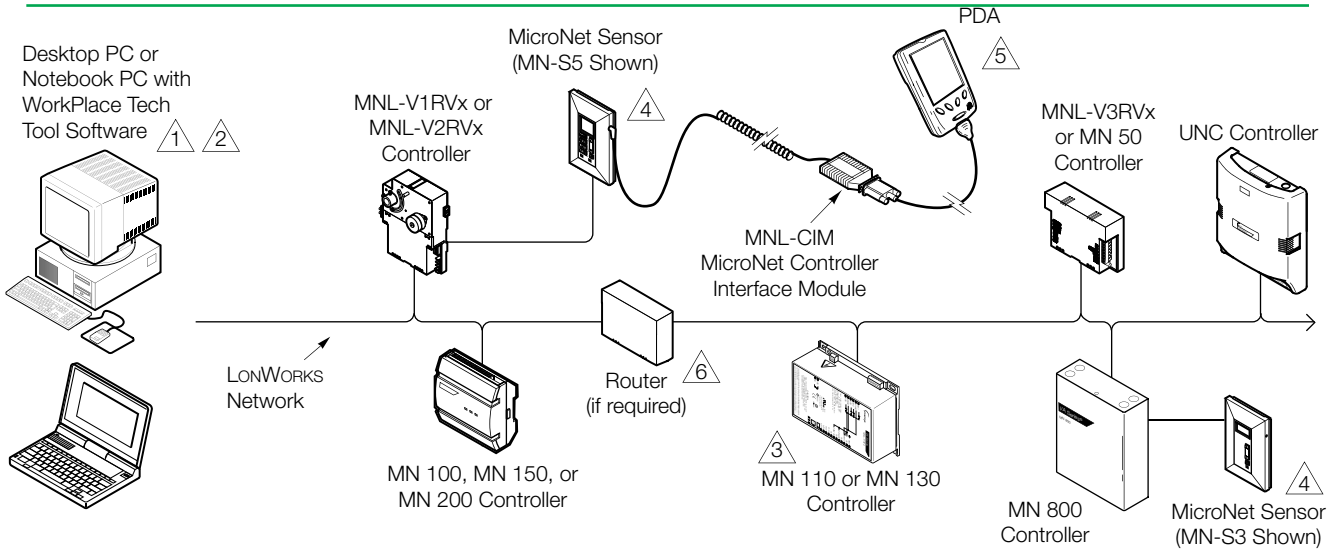

- 1 A PC can be connected to the LONWORKS TP/FT-10 Network, either directly or through the LONWORKS network jack of a LONWORKS controller or MN-Sxxx Wall Sensor. The PC must have an Echelon® LonTalk® adapter card.
- 2 Programming any of the TAC I/A Series controllers, or the TAC I/A Series MN 800 controller, requires WorkPlace Tech Tool.
- 3 This controller is not suitable for exposed mounting on a wall or panel, or in any other easily accessible place due to the possibility of personal contact with the high-voltage terminals. It must be mounted inside a suitable grounded metal enclosure.
- 4 MicroNet Sensors can be connected to any MN controller.
- 5 A PDA running the Pocket I/A interface software may be used to communicate with MicroNet I/A Series controllers.
- 6 When routers are used, WP Tech is able to communicate through them to any of the TAC I/A Series devices on the network.

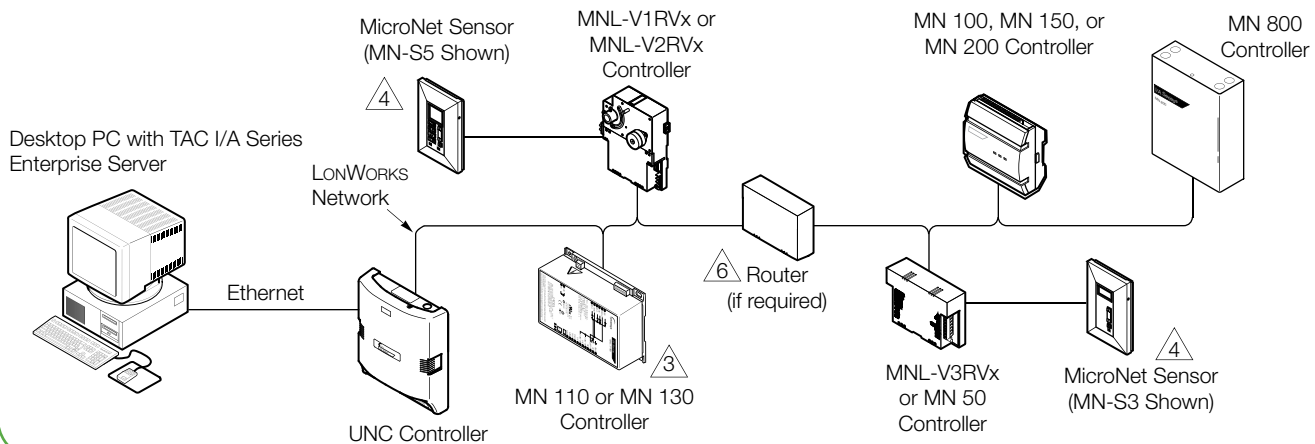

On October 1st, 2009, TAC became the Buildings Business of its parent company Schneider Electric. This document reflects the visual identity of Schneider Electric, however there remains references to TAC as a corporate brand in the body copy. As each document is updated, the body copy will be changed to reflect appropriate corporate brand changes. All brand names, trademarks and registered trademarks are the property of their respective owners. Information contained within this document is subject to change without notice. All rights reserved.