



B142 Series



ACCURATELY MEASURES GAS FLOW

DESCRIPTION

B142 Series gas turbine flow meter offers reliable measurement of natural gas flow rates in boiler systems. The stainless steel housing and tungsten carbide shaft and bearings are durable in any compatible environment. The unique wafer style design is fast and easy to install between two 2" ANSI flanges, reducing costly downtime. The B142 meter is compatible with the B3000 flow monitor for a complete flow monitoring system. The B142 is also compatible with most standard computers, simplifying configuration within existing systems.

FEATURES

- Consistent, reliable gas flow measurement
- Wafer mounting configuration...better fit in limited spaces
- Lightweight balanced rotor...quick response to changes in flow rate
- No mating flange design...allows quick and easy installation
- Durable construction material...reliable performance in harsh environmental conditions

APPLICATIONS

- Monitoring flow of natural gas in boilers or other industrial systems

SPECIFICATIONS

FLOW MEASUREMENT RANGE	
B142-20L	7 to 70 ACFM*; 10 to 100 MCFD**; 423 to 4230 MBHT 365 pulses per ACF (12900 pulses per m3)
B142-20M	14 to 210 ACFM*; 20 to 300 MCFD**; 846 to 12690 MBHT 190 pulses per ACF (6710 pulses per m3)
B142-20H	35 to 350 ACFM*; 50 to 500 MCFD**; 2115 to 21150 MBHT 85 pulses per ACF (3000 pulses per m3)
SYSTEM	
Working Pressure	Vacuum to 2220 psig (15.3 MPa)
Pressure Drop	3" of water column (7.5 mbar) at maximum rated flow rate (dry air)
Pressure Port	1/8" NPTF (plugged)
Operating Temperature Range	-40 to +165 °C (-40 to +330 °F)
Output Voltage	100 mV-P-P minimum when used with B111113 magnetic pickup
ACCURACY	
Linearity	±2% of reading over the specified measurement range
Uncertainty	±1% of reading when calibration data is entered into an intelligent monitor/transmitter
Repeatability	±0.5%
Construction	
Body and Cartridge	316/316L stainless steel
Bearing Mounts	304 stainless steel
Set Screws and Pressure Port Plug	316 stainless steel
Bearings and Rotor Shaft	Tungsten carbide
Rotor	410 stainless steel
CONNECTIONS	
Pickup	Mates with AN3106A-10SL connector
Conduit	1" NPT (25 mm)
COMPLIANCE INFORMATION	
Agency Approvals	UL913; CSA 22.2 No. 157-92; Class 1 Division 1 Groups C, D
Explosion Proof	UL1203; CSA 22.2 No. 30-M1986; Class 1 Division 1 Groups C, D
Seal	ANSI/ISA 12.27.01-2003
WARRANTY	
Limited Warranty	1 year



DIMENSIONAL DRAWINGS

B142 Meter with B111113 Magnetic Pickup Installed

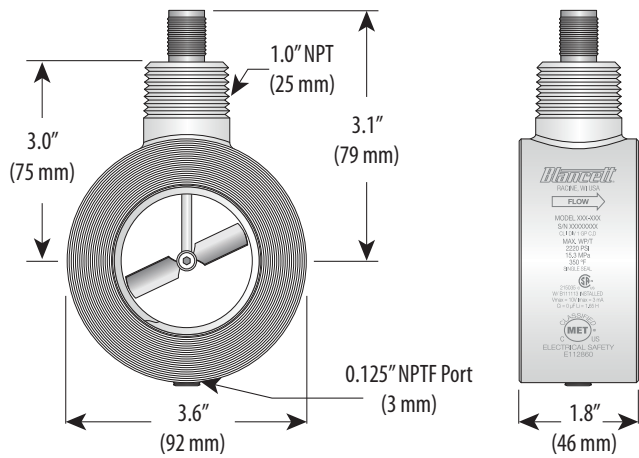

FLOW SYSTEM ELEMENTS

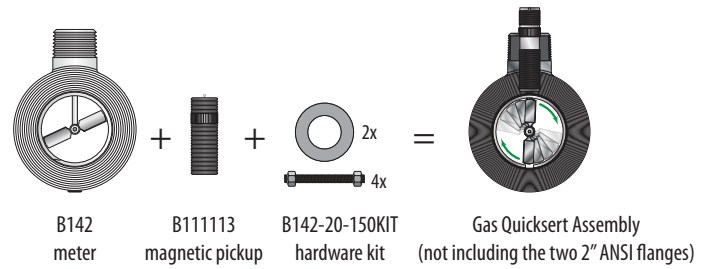

APPLICATION EXAMPLE

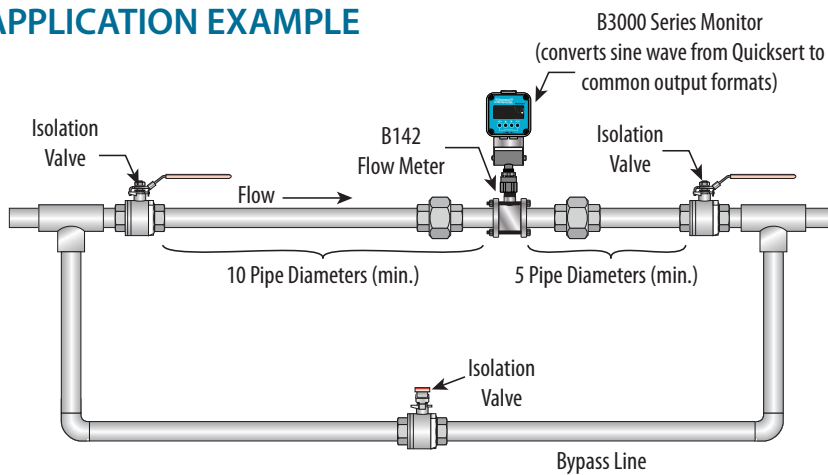

ORDERING INFORMATION



PART #	MANUFACTURER PART #	DESCRIPTION
U021-0001	B142-20L	Flow, Gas, Quicksert, 2", SS, Low Rate,Pulse
U021-0002	B142-20M	Flow, Gas, Quicksert, 2", SS, Med Rate,Pulse
U021-0003	B142-20H	Flow, Gas, Quicksert, 2", SS, High Rate,Pulse
U021-0004	B111113	Flow, Gas, Quicksert, Magnetic Pickup, SS
U021-0005	B142-20-150KIT	Flow, Gas, Quicksert, Bolt and Gasket Kit

ACCESSORIES

B30xx Series Monitor for a complete flow monitoring system B220 remote cable assembly



B220



B30xx
(shown with the B142 meter connected)